



Industrial Automation Headquarters

Delta Electronics, Inc.
Taoyuan Technology Center
No.18, Xinglong Rd., Taoyuan District,
Taoyuan City 33068, Taiwan
TEL: 886-3-362-6301 / FAX: 886-3-371-6301

Asia

Delta Electronics (Shanghai) Co., Ltd.
No.182 Minyu Rd., Pudong Shanghai, P.R.C.
Post code : 201209
TEL: 86-21-6872-3988 / FAX: 86-21-6872-3996
Customer Service: 400-820-9595

Delta Electronics (Japan), Inc.
Tokyo Office
Industrial Automation Sales Department
2-1-14 Shibadaimon, Minato-ku
Tokyo, Japan 105-0012
TEL: 81-3-5733-1155 / FAX: 81-3-5733-1255

Delta Electronics (Korea), Inc.
Seoul Office
1511, 219, Gasan Digital 1-Ro., Geumcheon-gu,
Seoul, 08501 South Korea
TEL: 82-2-515-5305 / FAX: 82-2-515-5302

Delta Energy Systems (Singapore) Pte Ltd.
4 Kaki Bukit Avenue 1, #05-04, Singapore 417939
TEL: 65-6747-5155 / FAX: 65-6744-9228

Delta Electronics (India) Pvt. Ltd.
Plot No.43, Sector 35, HSIIDC Gurgaon,
PIN 122001, Haryana, India
TEL: 91-124-4874900 / FAX : 91-124-4874945

Delta Electronics (Thailand) PCL.
909 Soi 9, Moo 4, Bangpoo Industrial Estate (E.P.Z),
Pattana 1 Rd., T.Phraksa, A.Muang,
Samutprakarn 10280, Thailand
TEL: 66-2709-2800 / FAX : 662-709-2827

Delta Energy Systems (Australia) Pty Ltd.
Unit 20-21/45 Normanby Rd., Notting Hill Vic 3168, Australia
TEL: 61-3-9543-3720

Americas

Delta Electronics (Americas) Ltd.
Raleigh Office
P.O. Box 12173, 5101 Davis Drive,
Research Triangle Park, NC 27709, U.S.A.
TEL: 1-919-767-3813 / FAX: 1-919-767-3969

Delta Electronics Brazil
São Paulo Office
Rua Itapeva, 26 – 3º, andar Edifício Itapeva
One- Bela Vista 01332-000 - São Paulo - SP - Brazil
TEL: 55-12-3932-2300 / FAX: 55-12-3932-237

Delta Electronics International Mexico S.A. de C.V.
Mexico Office
Gustavo Baz No. 309 Edificio E PB 103
Colonia La Loma, CP 54060
Tlalnepanitla, Estado de México
TEL: 52-55-3603-9200

*We reserve the right to change the information in this catalogue without prior notice.

EMEA

Headquarters: Delta Electronics (Netherlands) B.V.
Sales: Sales.IA.EMEA@deltaww.com
Marketing: Marketing.IA.EMEA@deltaww.com
Technical Support: iatechnicalsupport@deltaww.com
Customer Support: Customer-Support@deltaww.com
Service: Service.IA.emea@deltaww.com
TEL: +31(0)40 800 3900

BENELUX: Delta Electronics (Netherlands) B.V.
De Witbogt 20, 5652 AG Eindhoven, The Netherlands
Mail: Sales.IA.Benelux@deltaww.com
TEL: +31(0)40 800 3900

DACH: Delta Electronics (Netherlands) B.V.
Coesterweg 45, D-59494 Soest, Germany
Mail: Sales.IA.DACH@deltaww.com
TEL: +49(0)2921 987 0

France: Delta Electronics (France) S.A.
ZI du bois Challand 2, 15 rue des Pyrénées,
Lisses, 91090 Evry Cedex, France
Mail: Sales.IA.FR@deltaww.com
TEL: +33(0)1 69 77 82 60

Iberia: Delta Electronics Solutions (Spain) S.L.U
Ctra. De Villaverde a Vallecas, 265 1º Dcha Ed.
Hormigueras – P.I. de Vallecas 28031 Madrid
TEL: +34(0)91 223 74 20
Carrer Llacuna 166, 08018 Barcelona, Spain
Mail: Sales.IA.Iberia@deltaww.com

Italy: Delta Electronics (Italy) S.r.l.
Via Meda 2-22060 Novedrate(CO)
Piazza Grazioli 18 00186 Roma Italy
Mail: Sales.IA.Italy@deltaww.com
TEL: +39 039 8900365

Russia: Delta Energy System LLC
Vereyskaya Plaza II, office112 Vereyskaya str.
17 121357 Moscow Russia
Mail: Sales.IA.RU@deltaww.com
TEL: +7 495 644 3240

Turkey: Delta Greentech Elektronik San. Ltd. Sti. (Turkey)
Şerifali Mah. Hendem Cad. Kule Sok. No:16-A
34775 Ümraniye – İstanbul
Mail: Sales.IA.Turkey@deltaww.com
TEL: + 90 216 499 9910

GCC: Delta Energy Systems AG (Dubai BR)
P.O. Box 185668, Gate 7, 3rd Floor, Hamarain Centre
Dubai, United Arab Emirates
Mail: Sales.IA.MEA@deltaww.com
TEL: +971(0)4 2690148

Egypt + North Africa: Delta Electronics
Unit 318, 3rd Floor, Trivium Business Complex, North 90 street, New
Cairo, Cairo, Egypt
Mail: Sales.IA.MEA@deltaww.com

Delta High Resolution AC Servo Drive for Network Communication Applications ASDA-A2 Series User Manual



Delta High Resolution AC Servo Drive for Network Communication Applications ASDA-A2 Series User Manual

www.deltaww.com



Preface

Thank you for purchasing ASDA-A2. This user manual provides the related information of ASDA-A2 series servo drive and ECMA series servo motors. This manual includes:

- Installation and inspection of servo drive and servo motor
- The configuration of servo drive
- Procedures of trial run
- Control function and adjustment methods of servo drive
- Parameters
- Communication protocol
- Maintenance and inspections
- Troubleshooting

This manual addresses personnel with the following qualifications:

- Servo system designers
- Installation or wiring personnel
- Trial and tuning personnel
- Maintenance and inspection personnel

Before using the product, please read through this manual carefully in order to ensure the correct use of the product. In addition, please place this manual safely for quick reference whenever is needed. Please follow the rules below if you have not finished reading this manual yet.

- No vapor, corrosive gas, and inflammable gas are allowed in installation environment.
- Three-phase power is prohibited to connect to U, V and W connector when wiring. It is possible to damage the servo drive.
- Ground is a must.
- Do not disassemble the servo drive, motor or change the wiring when connecting to the power.
- Be ensured that the emergency stop can be activated anytime before connecting to the power and operation.
- Do not touch the heat sink to avoid scald before connecting to the power and operation.

If you have any enquiry, please contact the distributors or Delta customer service center.

Safety Precautions

ASDA-A2 series is the high resolution and open type servo drive. It should be installed in a shielded control box during operation. This servo drive uses precise feedback control and the digital signal processor with high-speed calculation function to control the current output generated by IGBT so as to operate three-phase permanent magnet synchronous motors (PMSM) and to achieve precise positioning.

ASDA-A2 is applicable on industrial application and is suggested to be installed in the distribution board. (Servo drives, wire rod, and motors all should be installed in the environment which complies with the minimum requirement of UL Level 1.)

Pay special attention to the following safety precautions anytime during inspection, installation, wiring, operation, and examination.

The symbol of **danger**, **warning** and **stop** represent:



It indicates the potential hazards. It is possible to cause severe injury or fatal harm if not following the instructions.



It indicates the potential hazards. It is possible to cause minor injury or lead to serious damage of the product or even malfunction if not following the instructions.



It indicates the absolute prohibited activity. It is possible to damage the product or cannot be used due to malfunction if not following the instructions.

Inspection



- Please follow the instruction when using servo drive and servo motor, or it is possible to cause fire or malfunction.

Installation



- It is prohibited to expose the product with the environment containing vapor, corrosive gas, inflammable gas, etc. Or it is possible to cause electric shock or fire.

Wiring



- Please connect the ground terminal to class-3 ground system (under 100Ω); poor grounding may result in electric shock or fire.
- Do not connect the three-phase source to the motor output terminal U, V and W. Or it is possible to cause personnel injury or fire.
- Please tighten the screws of the power and motor output terminal. Or it is possible to cause fire.
- Please connect wiring according to the wire rod in order to prevent any danger.

Operation



- Before the operation, please change the parameter setting value according to the needs. If it is not adjusted to the correct setting value, it is possible to lead to malfunction of the machine or the operation might be out of control.
- Before the machine starts to operate, please be ensured the emergency stop can be activated anytime.
- When power on, please make sure the motor shaft stands still and will not operate because of mechanical inertia or other causes.



- During the operation, it is prohibited to touch any rotating motor parts. Or it is possible to cause personnel injury.



- In order to prevent any accident, please separate the couplings and belts of the machine and isolate them. Then, conduct the initial trial run.
- If users fail to operate the machine properly after the servo motor connects to the equipment, it would cause the damage of the equipment and lead to the personnel injury.
- In order to prevent the danger, it is strongly recommended to check if the motor can operate normally without load first. Then, operate the motor with load.
- Do not touch the heat sink of the servo drive. Or it is possible to cause scald due to the high temperature.

Maintenance and Inspection



- It is prohibited to touch the internal parts of the servo drive and servo motor. Or it is possible to cause electric shock.
- It is prohibited to disassemble the panel of the servo drive when turning on the power. Or it is possible to cause electric shock.
- Do not touch the ground terminal within 10 minutes after turning off the power. Or the residual voltage may cause electric shock.
- Do not disassemble the motor. Or it is possible to cause electric shock or personnel injury.
- Do not change the wiring when the power is on. Or it is possible to cause electric shock or personnel injury.
- Only the qualified electrical and electronics professionals can install, wire, and maintain the servo drive and servo motor.

Main Circuit Wiring



- Do not put the power cable and the encoder cable in the same channel and bond them together. Please separate the power cable and the encoder cable for at least 30 centimeters (= 11.8 inches) when wiring.
- Please use stranded wires and multi-core shielded-pair wires for the encoder cables and encoder feedback cables. The maximum length of command input cable is 3 meters (= 9.84 feet) and the maximum length of feedback cable is 20 meters (= 65.62 feet).
- The high voltage might remain in the servo motor even when the power is off. Do not touch the power terminal temporarily (at least 10 minutes). Please conduct the inspection not until the indicator light, **CHARGE** is off.



- Do not turn the power on and off too often. If continuous power on and off is needed, please be ensured the interval is one minute at most.

Terminal Wiring of the Main Circuit



- When wiring, please disassemble the terminal socket from the servo drive.
- One terminal of the terminal socket for one electric wire only.
- When inserting the electric wires, do not connect the conductor to the adjacent wire.
- Before connecting to the power, please inspect and be ensured the wiring is correct.

Note: if there is any difference of each version, please refer to Delta's website (<http://www.delta.com.tw/industrialautomation/>) for the latest information.

Table of Contents

Chapter 1	Inspection and Model Explanation	1-1
1.1	Inspection	1-1
1.2	Product Model	1-3
1.2.1	Nameplate Information	1-3
1.2.2	Model Explanation	1-5
1.3	Servo Drive and Corresponding Servo Motor	1-8
1.3.1	ASDA-A2 220V Series	1-8
1.3.2	ASDA-A2 400V Series	1-10
1.4	Each Part of the Servo Drive	1-11
1.4.1	ASDA-A2 220V Series	1-11
1.4.2	ASDA0A2 400V Series	1-14
1.5	ASDA-A2-XN Series	1-16
1.5.1	Model Explanation	1-16
1.5.2	ASDA-A2-XN Series Servo Drive and Corresponding Motor	1-19
1.5.3	Each Part of the ASDA-A2-XN Series Servo Drive	1-20
Chapter 2	Installation	2-1
2.1	Notes	2-1
2.2	Ambient Conditions of Storage	2-1
2.3	Ambient Conditions of Installation	2-1
2.4	Installation Direction and Space	2-2
2.5	Specification of Circuit Breaker and Fuse	2-4
2.6	Ferrite Ring	2-5

2.7	EMI Filter Selection	2-8
2.8	Selection of Regenerative Resistor	2-11
2.9	The Use of Servo Motor	2-20
2.9.1	Troubleshooting for the Motor Operation and Status	2-20
2.9.2	Mounting Directions and Precautions for the Servo Motor	2-21
2.9.3	Precautions for Using Servo Motors with Oil Seal	2-22
2.9.4	Precautions for Using Couplings	2-22
2.9.5	Oil and Water Prevention Measures for the Servo Motor	2-23
2.9.6	Measures to Suppress Temperature Increase of the Servo Motor	2-24
Chapter 3	Wiring	3-1
3.1	Connections – 220V series	3-1
3.1.1	Connecting to Peripheral Devices	3-1
3.1.2	Connectors and Terminals of Servo Drive	3-3
3.1.3	Wiring Method	3-5
3.1.4	Specification of Motor Power Cable	3-7
3.1.5	Specification of Encoder Cable Connector	3-9
3.1.6	Selection of Wiring Rod	3-15
3.2	Connections – 400V series	3-17
3.2.1	Connecting to Peripheral Devices	3-17
3.2.2	Connectors and Terminals of the Servo Drive	3-18
3.2.3	Wiring Method	3-20
3.2.4	Specification of Motor Power Cable	3-21
3.2.5	Specification of Encoder Connector	3-23
3.2.6	Selection of Wiring Rod	3-25
3.3	Basic Wiring	3-27

3.3.1	220V series	3-27
3.3.2	400V series	3-30
3.4	I/O Signal (CN1) Connection	3-32
3.4.1	I/O Signal (CN1) Connector Terminal Layout	3-32
3.4.2	Signals Explanation of Connector CN1	3-34
3.4.3	Wiring Diagrams (CN1)	3-44
3.4.4	DI and DO Signal Specified by Users	3-53
3.4.5	Application: Using CN1 Quick Connector for Wiring	3-53
3.5	CN2 Connector	3-58
3.6	Wiring of CN3 Connector	3-61
3.6.1	Layout of CN3 Connector	3-61
3.6.2	Connection between PC and Connector CN3	3-62
3.7	CN4 Serial Connector (USB)	3-63
3.8	CN5 Connector (Full-closed loop)	3-64
3.9	CN6 Connector (CANopen)	3-65
3.9.1	CANopen communication	3-65
3.9.2	DMCNET communication	3-67
3.10	Expansion Digital Input Connector of CN7	3-69
3.11	CN8 Connector of Battery Box	3-70
3.12	Standard Connection Example – 220V series	3-71
3.12.1	Position (PT) Control Mode	3-71
3.12.2	Position (PR) Control Mode	3-72
3.12.3	Speed Control Mode	3-73
3.12.4	Torque Control Mode	3-74
3.12.5	Communication Mode	3-75

3.13	Standard Connection Example – 400V series	3-76
3.13.1	Position (PT) Control Mode	3-76
3.13.2	Position (PR) Control Mode	3-77
3.13.3	Speed Control Mode	3-78
3.13.4	Torque Control Mode	3-79
3.13.5	Communication Mode	3-80
3.14	Differences between A2-XN and A2 Series Servo Drives	3-81
3.14.1	Connecting to Peripheral Devices (A2-EN model as an example)	3-81
3.14.2	Connectors of A2-XN Servo Drives	3-82
3.14.3	CN1 I/O 50-pin Connector (applicable to –LN series and 4.5kW ~ 7.5kW models of –FN and –MN series)	3-82
3.14.4	CN1 I/O 26-pin Connector (applicable to -EN series and 3kW models or below of –FN and –MN Series)	3-84
3.14.5	CN3 Communication Connector (applicable to –LN series and 4.5kW ~ 7.5kW models of –FN and –MN series)	3-85
3.14.6	EtherCAT Communication Connector (applicable to –EN models)	3-86
3.14.7	CN-STO (Safe Torque Off)	3-89
3.14.8	How does the STO Function Work?	3-90
3.14.9	Related Parameter of the STO Function	3-91
3.14.10	Position (PT) Control Mode	3-94
3.14.11	Position (PR) Control Mode	3-95
3.14.12	Speed Control Mode	3-96
3.14.13	Torque Control Mode	3-97
3.14.14	Communication Mode	3-98

Chapter 4	Panel Display and Operation	4-1
4.1	Panel Description.....	4-1
4.2	Parameter Setting Procedure	4-2
4.3	Status Display.....	4-5
4.3.1	Save Setting Display.....	4-5
4.3.2	Decimal Point.....	4-5
4.3.3	Alarm Message	4-5
4.3.4	Positive and Negative Sign Setting	4-6
4.3.5	Monitor Display.....	4-6
4.4	General Function	4-9
4.4.1	Operation of Fault Record Display	4-9
4.4.2	JOG Mode.....	4-10
4.4.3	Force DO Output	4-11
4.4.4	Digital Input Diagnosis Operation.....	4-12
4.4.5	Digital Output Diagnosis Operation	4-12
Chapter 5	Trial Operation and Tuning	5-1
5.1	Inspection without Load.....	5-1
5.2	Applying Power to the Servo Drive.....	5-2
5.3	JOG Trial Run without Load	5-6
5.4	Trial Run without Load (Speed Mode).....	5-7
5.5	Trial Run without Load (Position Mode).....	5-9
5.6	Tuning Procedure	5-11
5.6.1	Flowchart of Tuning Procedure.....	5-12
5.6.2	Inertia Estimation Flowchart (with Mechanism)	5-13
5.6.3	Flowchart of Auto Tuning	5-14

5.6.4	Flowchart of Semi-Auto Tuning	5-15
5.6.5	Limit of Inertia Ratio.....	5-16
5.6.6	Mechanical Resonance Suppression Method	5-17
5.6.7	Tuning Mode and Parameters.....	5-19
5.6.8	Tuning in Manual Mode	5-20
Chapter 6	Control Mode of Operation	6-1
6.1	Selection of Operation Mode	6-1
6.2	Position Mode	6-3
6.2.1	Position Command in PT Mode	6-3
6.2.2	Position Command in PR Mode.....	6-7
6.2.3	Control Structure of Position Mode.....	6-8
6.2.4	S-curve Filter (Position)	6-9
6.2.5	Electronic Gear Ratio.....	6-12
6.2.6	Low-pass Filter	6-15
6.2.7	Timing Diagram in Position Mode (PR)	6-16
6.2.8	Gain Adjustment of Position Loop	6-17
6.2.9	Low-frequency Vibration Suppression in Position Mode	6-20
6.3	Speed Mode	6-25
6.3.1	Selection of Speed Mode.....	6-25
6.3.2	Control Structure of Speed Mode.....	6-26
6.3.3	Smooth Speed Command.....	6-27
6.3.4	The Scaling of Analog Command.....	6-31
6.3.5	Timing Diagram in Speed Mode	6-32
6.3.6	Gain Adjustment of Speed Loop.....	6-33
6.3.7	Resonance Suppression.....	6-40

6.4	Torque Mode	6-48
6.4.1	Selection of Torque Command	6-48
6.4.2	Control Structure of Torque Mode	6-49
6.4.3	Smooth Torque Command	6-50
6.4.4	The Scaling of Analog Command	6-51
6.4.5	Timing Diagram in Torque Mode	6-52
6.5	Dual Mode	6-53
6.5.1	Speed / Position Dual Mode	6-54
6.5.2	Speed / Torque Dual Mode	6-54
6.5.3	Torque / Position Dual Mode	6-55
6.6	Others	6-56
6.6.1	The Use of Speed Limit	6-56
6.6.2	The Use of Torque Limit	6-57
6.6.3	Analog Monitor	6-58
6.6.4	The Use of Brake	6-62
Chapter 7	Motion Control	7-1
7.1	Motion Control Functions of ASDA-A2	7-1
7.2	System Information	7-1
7.2.1	Description of Monitoring Variables	7-2
7.2.2	Description of Data Array	7-9
7.3	Description of Motion Axes	7-12
7.4	Description of PR Mode	7-13
7.5	The Difference between General PR Mode and the One in ASDA-A2	7-13
7.6	The Position Unit of PR Mode	7-14
7.7	Description of Register in PR Mode	7-14

7.8	Homing Description of PR Mode.....	7-16
7.9	DI/DO Provided by PR Mode and Diagrams.....	7-16
7.10	Parameter Settings	7-18
7.10.1	The Relation between the Previous Path and the Next Path	7-25
7.10.2	Programming the Path in PR Mode	7-26
7.11	The Description of E-Cam Function.....	7-27
7.11.1	Function Description of CAPTURE (Data Capture)	7-34
7.11.2	Function Description of COMPARE (Data Compare).....	7-36
Chapter 8	Parameters	8-1
8.1	Parameter Definition.....	8-1
8.2	List of Parameters.....	8-2
8.3	Parameter Description	8-14
P0-xx	Monitor Parameters	8-14
P1-xx	Basic Parameters.....	8-37
P2-xx	Extension Parameters.....	8-91
P3-xx	Communication Parameters	8-136
P4-xx	Diagnosis Parameters.....	8-146
P5-xx	Motion Setting Parameters.....	8-160
P6-xx	PR Parameters.....	8-225
P7-xx	PR Parameters.....	8-267
Table 8.1	Function Description of Digital Input (DI).....	8-279
Table 8.2	Function Description of Digital Output (DO).....	8-289
Chapter 9	Communications.....	9-1
9.1	RS-485 & RS-232 Communication Hardware Interface.....	9-1
9.2	RS-485 & RS-232 Communication Parameters Setting.....	9-3

9.3	MODBUS Communication Protocol.....	9-6
9.4	Write-in and Read-out Communication Parameters	9-18
Chapter 10	Troubleshooting.....	10-1
10.1	Alarm of Servo Drive	10-1
10.2	Alarm of CANopen Communication.....	10-6
10.3	Alarm of Motion Control.....	10-8
10.4	Causes and Corrective Actions	10-12
10.5	Corrective Actions after the Alarm Occurs	10-38
Chapter 11	Specifications.....	11-1
11.1	Specifications of Servo Drives (ASDA-A2 Series).....	11-1
11.1.1	ASDA-A2 220V Series.....	11-1
11.1.2	ASDA-A2 400V Series.....	11-4
11.2	Specifications of Servo Motors (ECMA Series)	11-7
11.2.1	ECMA 220V Series	11-7
11.2.2	ECMA 400V Series	11-17
11.3	Torque Features (T-N Curves)	11-25
11.3.1	220V Series	11-25
11.3.2	400V Series	11-27
11.4	Overload Features	11-29
11.5	Dimensions of Servo Drive.....	11-31
11.5.1	220V Series	11-31
11.5.2	400V Series	11-38
11.6	Dimensions of Servo Motor (ECMA Series).....	11-41
11.6.1	220V Series	11-41
11.6.2	400V Series	11-48

Chapter 12 Absolute System	12-1
12.1 Battery Box (absolute type) and wiring.....	12-2
12.1.1 Specifications	12-2
12.1.2 Battery Box Dimensions.....	12-4
12.1.3 Connection Cables for Absolute Encoder.....	12-5
12.1.4 Battery Box Cords	12-7
12.2 Installation.....	12-8
12.2.1 Connection Examples.....	12-8
12.2.2 How to Install a Battery	12-12
12.2.3 How to Replace a Battery.....	12-14
12.3 System Initialization Procedure and Operation.....	12-16
12.3.1 System Initialization Procedure.....	12-16
12.3.2 Pulse Counting	12-17
12.3.3 PUU Counting	12-18
12.3.4 Use Digital Inputs/Outputs to Create the Absolute Origin Coordinate.....	12-19
12.3.5 Use Parameters to Create the Absolute Origin Coordinate	12-19
12.3.6 Use Digital Inputs/Outputs to Read the Absolute Coordinate Data	12-20
12.3.7 Use Parameter to Read the Absolute Coordinate Data.....	12-23
12.4 Related Parameters for Absolute System	12-24
12.5 Digital Input (DI) Function Definition (for Absolute System).....	12-29
12.6 Digital Output (DO) Function Definition (for Absolute System)	12-30
12.7 Alarms for Absolute System	12-31
12.7.1 Causes and Corrective Actions.....	12-32
12.8 Related Monitoring Variables.....	12-34

Appendix A Accessories.....A-1

Appendix B Maintenance and InspectionB-1

(This page is intentionally left blank.)

Chapter 1 Inspection and Model Explanation

1.1 Inspection

In order to prevent the negligence during purchasing and delivery, please inspect the following items carefully.

- Please check if the product is what you have purchased: check the part number of the motor and the servo drive on the nameplate. Refer to the next section for the model explanation.
- Check if the motor shaft can rotate smoothly: rotate the motor shaft by hand. If it can be rotated smoothly, it means the motor shaft is normal. However, it cannot be rotated by hand if the motor has an electromagnetic brake.
- Check if there is any damage shown on its appearance: visually check if there is any damage or scrape of the appearance.
- Check if there is any loose screw: if the screws are un-tightened or fall off.

If any of the above situations happens, please contact the distributors to solve the problems.

A complete and workable servo set should include:

- (1) A servo drive and a servo motor
- (2) A UVW motor power cable, the U, V, and W wires can connect to the socket attached by the servo drive and the other side is the plug which could connect to the socket of the motor. And a green ground wire which should be locked to the ground terminal of the servo drive. (selective purchase)
- (3) An encoder cable which connects to the socket of the encoder. One side of it connects to the CN2 on the servo drive and the other side is the plug. (selective purchase)
- (4) A 50-PIN connector which is used in CN1 (selective purchase)
- (5) A 20-PIN connector which is used in CN2 (selective purchase)
- (6) A 6-PIN connector which is used in CN3 and is for general communication (RS-485) (selective purchase)
- (7) A 4-PIN connector which is used in CN4 (USB Type B product) (selective purchase)
- (8) An RJ45 connector which is used in CN6 and is for high-speed (CANopen) communication (selective purchase)
- (9) A 7-PIN connector which is used in CN7, for extension DI. (-U model) (selective purchase)

(10) Servo drive power input:

220V:

	Control circuit power	Main circuit power
100 W ~ 3 kW	L _{1C} , L _{2C} , ⊖ quick connector	R, S, T quick connector
4.5 kW ~ 15 kW	L _{1C} , L _{2C} , ⊖ terminal block	R, S, T terminal block

400V:

	Control circuit power	Main circuit power
750 W ~ 1.5 kW	DC24V, DC0V, ⊖ quick connector	R, S, T quick connector
2 kW ~ 7.5 kW	DC24V, DC0V, ⊖ terminal block	R, S, T terminal block

- (11) A 3-PIN quick connector (U, V, W)
- (12) A 3-PIN quick connector (P⁺, D, C)
- (13) A plastic lever (for 220V 100 W ~ 3 kW and 400V 750 W ~ 1.5 kW)
- (14) A metal short-circuit chip (for 220V 100 W ~ 4.5 kW and 400V 750 W ~ 1.5 kW)
- (15) An installation manual

1.2 Product Model

1.2.1 Nameplate Information

ASDA-A2 Series Servo Drive

■ Nameplate Information

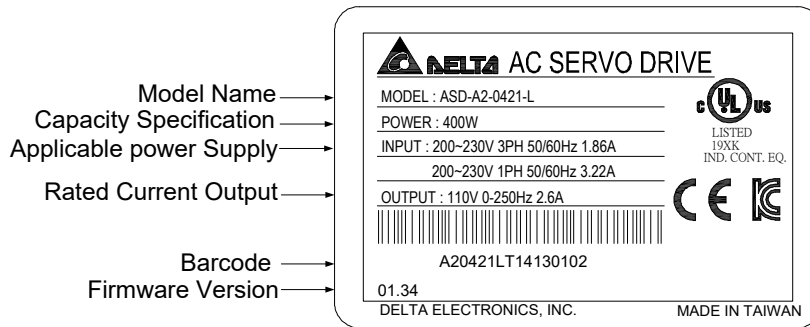

■ Serial Number

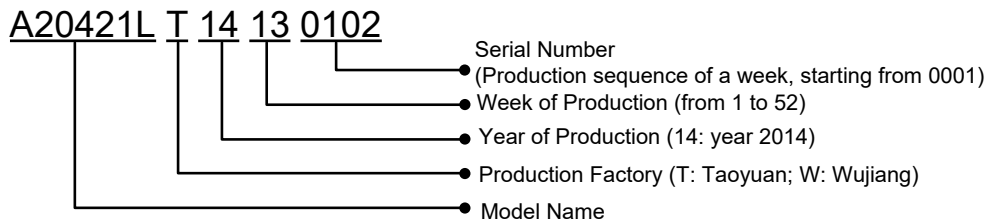

ECMA Series Servo Motor

■ Nameplate Information

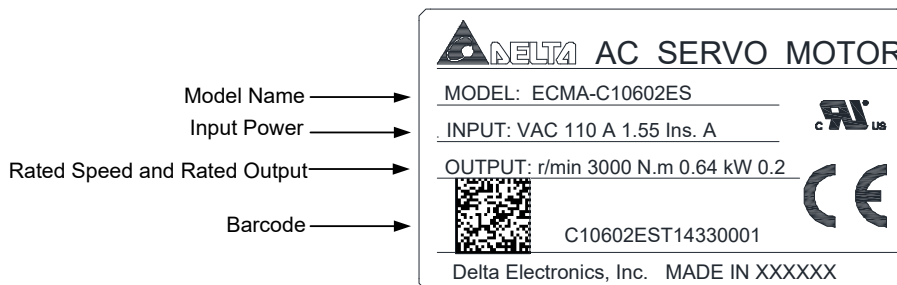

■ Serial Number

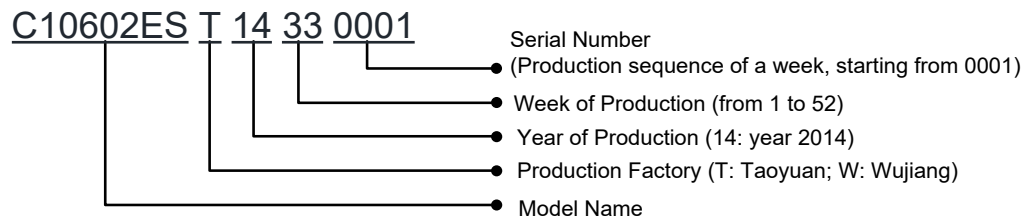

ECMC Series Servo Motor

■ Nameplate information

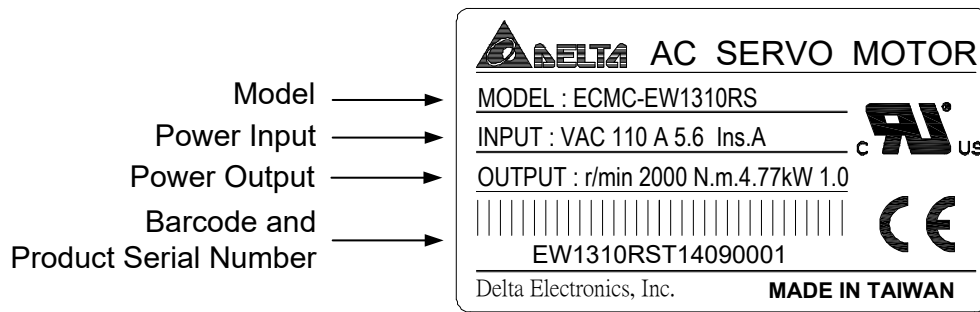

■ Serial Number

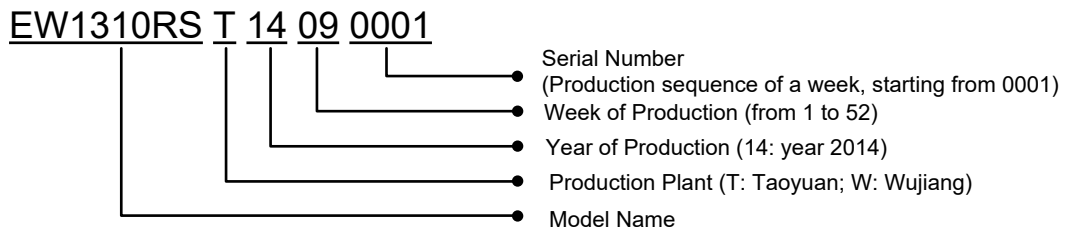

1.2.2 Model Explanation

ASDA-A2 Series Servo Drive

A S D - A 2 - 0 7 4 3 - U

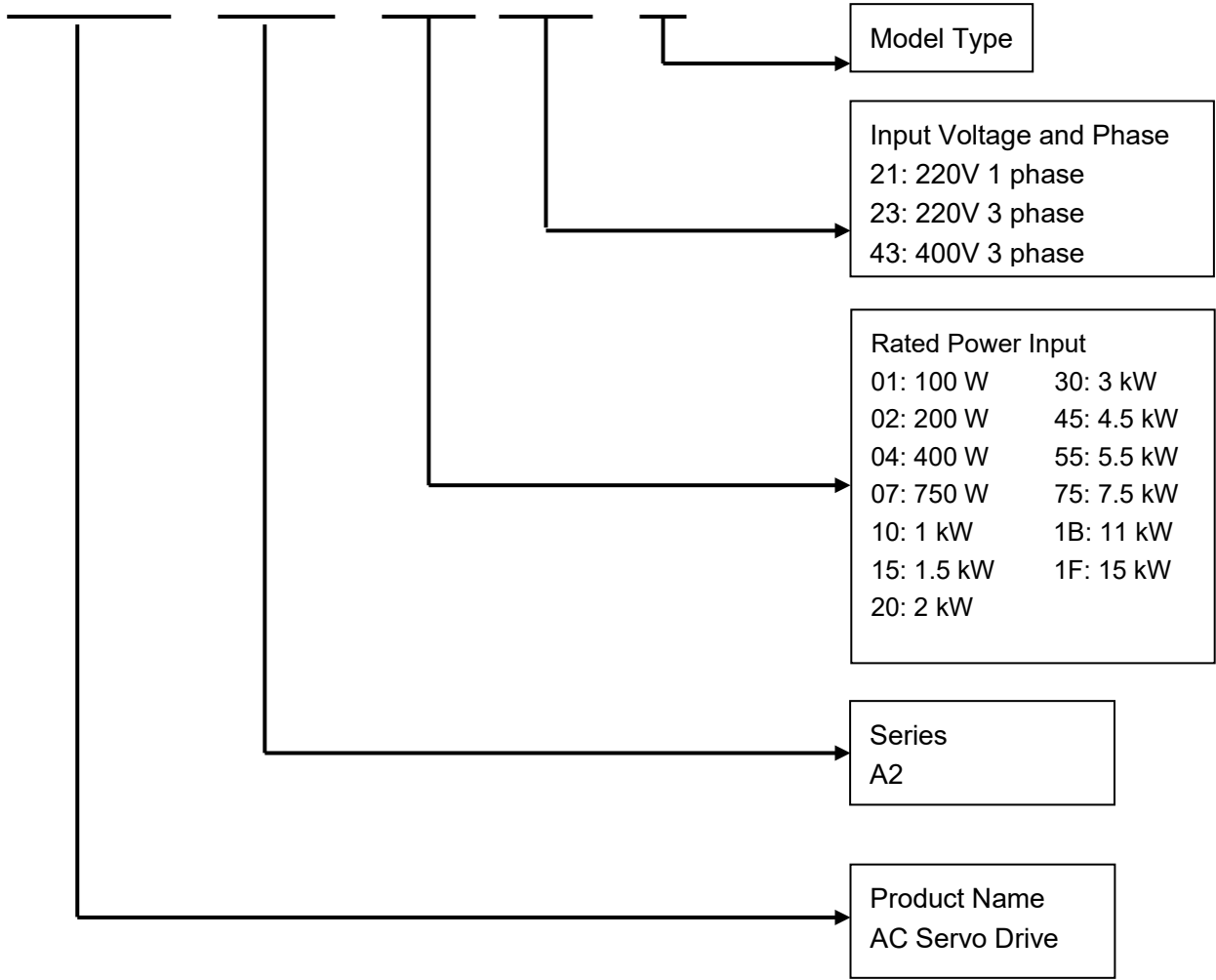

Model Type

Type	Standard		Network		
A2 Series	L	U	E	F	M
RS-485 (CN3)	O	O	X	O	O
Full-closed loop control (CN5)*1	O	O	O	O	O
DI expansion port (CN7)	X	O	O	X	X
EtherCAT	X	X	O	X	X
CANopen	X	X	X	X	O
DMCNET	X	X	X	O	X
Analog Voltage Control	O	O	X	X	O
Pulse Input	O	O	X	X	O
PR mode*2	O	O	O	O	O
E-Cam*3	X	O	O	X	O

Note:

1. In PR mode, only A2-F supports full-closed loop control function.
2. PR parameters can be read and written through communication by DMCNET only.
3. E-cam function can only be used in PR mode.

ECMA Series Servo Motor

E C M A - C 1 0 6 0 2 E S

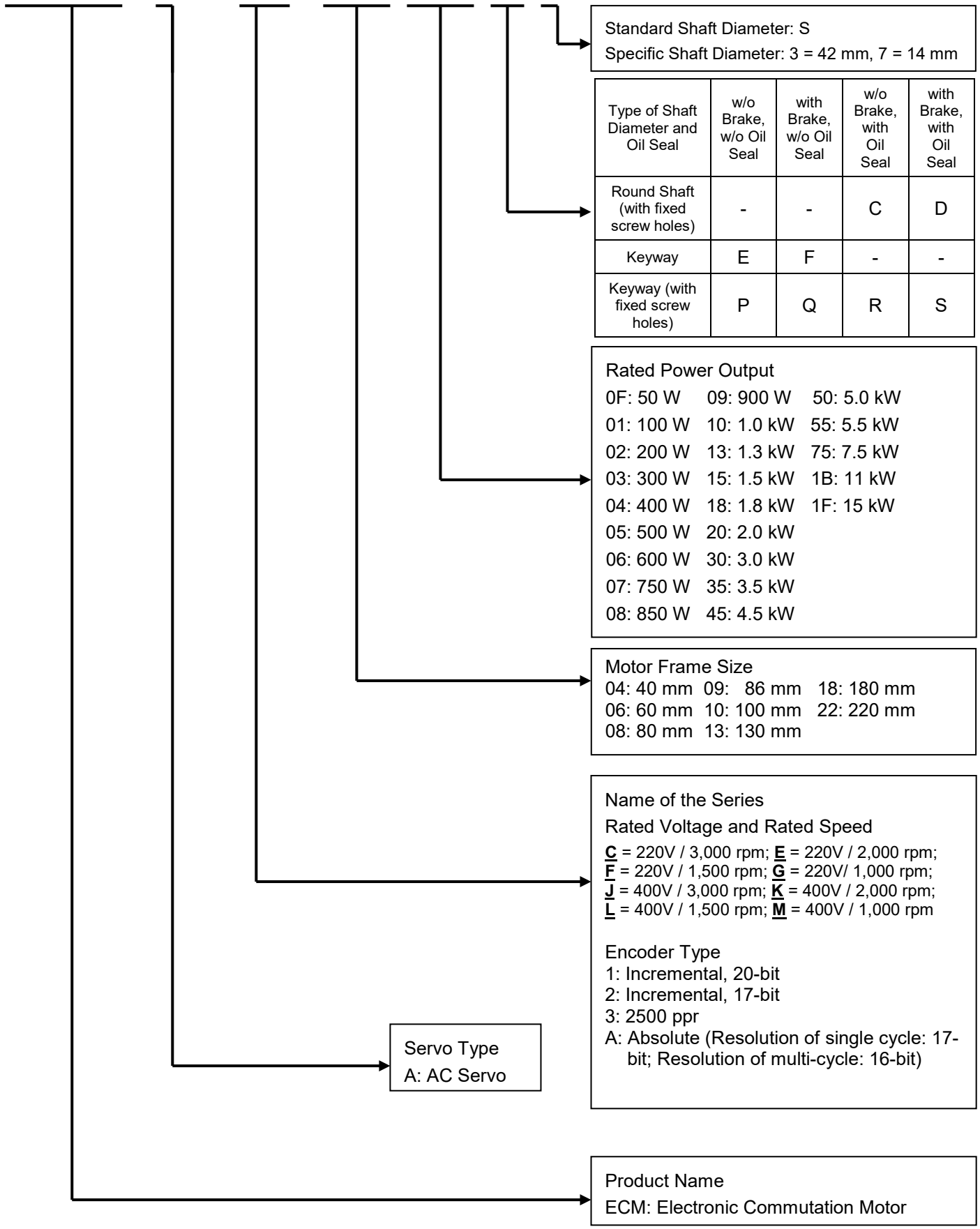

Standard Shaft Diameter: S
 Specific Shaft Diameter: 3 = 42 mm, 7 = 14 mm

Type of Shaft Diameter and Oil Seal	w/o Brake, w/o Oil Seal	with Brake, w/o Oil Seal	w/o Brake, with Oil Seal	with Brake, with Oil Seal
Round Shaft (with fixed screw holes)	-	-	C	D
Keyway	E	F	-	-
Keyway (with fixed screw holes)	P	Q	R	S

Rated Power Output

0F: 50 W	09: 900 W	50: 5.0 kW
01: 100 W	10: 1.0 kW	55: 5.5 kW
02: 200 W	13: 1.3 kW	75: 7.5 kW
03: 300 W	15: 1.5 kW	1B: 11 kW
04: 400 W	18: 1.8 kW	1F: 15 kW
05: 500 W	20: 2.0 kW	
06: 600 W	30: 3.0 kW	
07: 750 W	35: 3.5 kW	
08: 850 W	45: 4.5 kW	

Motor Frame Size

04: 40 mm	09: 86 mm	18: 180 mm
06: 60 mm	10: 100 mm	22: 220 mm
08: 80 mm	13: 130 mm	

Name of the Series
 Rated Voltage and Rated Speed

C = 220V / 3,000 rpm; **E** = 220V / 2,000 rpm;
F = 220V / 1,500 rpm; **G** = 220V / 1,000 rpm;
J = 400V / 3,000 rpm; **K** = 400V / 2,000 rpm;
L = 400V / 1,500 rpm; **M** = 400V / 1,000 rpm

Encoder Type

1: Incremental, 20-bit
 2: Incremental, 17-bit
 3: 2500 ppr
 A: Absolute (Resolution of single cycle: 17-bit; Resolution of multi-cycle: 16-bit)

Servo Type
 A: AC Servo

Product Name
 ECM: Electronic Commutation Motor

1.3 Servo Drive and Corresponding Servo Motor

1.3.1 ASDA-A2 220V Series

Motor						Servo Drive			
Motor series	Power	Output (W)	Model Number	Rated Current (Arms)	Max. Instantaneous current (Arms)	Model Number	Continuous Output Current (Arms)	Max. Instantaneous output current (Arms)	
Low Inertia	ECMA-C 3000 r/min	Single-/Three-phase	50	ECMA-C1040F□S	0.69	2.05	ASD-A2-0121-□	0.90	2.70
			100	ECMA-C△0401□S	0.90	2.70			
			200	ECMA-C△0602□S	1.55	4.65	ASD-A2-0221-□	1.55	4.65
			400	ECMA-C△0604□S	2.60	7.80	ASD-A2-0421-□	2.60	7.80
			400	ECMA-C△0804□7	2.60	7.80			
			750	ECMA-C△0807□S	5.10	15.30	ASD-A2-0721-□	5.10	15.30
			750	ECMA-C△0907□S	3.66	11.00			
			1000	ECMA-C△0910□S	4.25	12.37	ASD-A2-1021-□	7.30	21.90
			1000	ECMA-C△1010□S	7.30	21.90			
			2000	ECMA-C△1020□S	12.05	36.15	ASD-A2-2023-□	13.40	40.20
			3000	ECMA-C△1330□4	17.2	47.5	ASD-A2-3023-□	19.40	58.20
Medium Inertia	ECMA-E 2000 r/min	Single-/Three-phase	500	ECMA-E△1305□S	2.90	8.70	ASD-A2-0421-□	2.60	7.80
			1000	ECMA-E△1310□S	5.60	16.80	ASD-A2-1021-□	7.30	21.90
			1500	ECMA-E△1315□S	8.30	24.90	ASD-A2-1521-□	8.30	24.90
			2000	ECMA-E△1320□S	11.01	33.03	ASD-A2-2023-□	13.40	40.20
			2000	ECMA-E△1820□S	11.22	33.66			
			3000	ECMA-E△1830□S	16.10	48.30	ASD-A2-3023-□	19.40	58.20
			3500	ECMA-E△1835□S	19.20	57.60			
Medium-high inertia	ECMA-F 1500 r/min	Single-/Three-phase	500	ECMA-F△1305□S	3.90	12.10	ASD-A2-0721-□	5.10	15.30
			850	ECMA-F△1308□S	7.10	19.40	ASD-A2-1021-□	7.30	21.90
			1300	ECMA-F△1313□S	12.60	38.60	ASD-A2-2023-□	13.40	40.20
			1800	ECMA-F△1318□S	13.00	36.00			
			3000	ECMA-F△1830□S	19.40	58.20	ASD-A2-3023-□	19.40	58.20
			4500	ECMA-F△1845□S	32.50	81.30	ASD-A2-4523-□	32.50	70.71
			5500	ECMA-F△1855□3	40.00	100.00	ASD-A2-5523-□	40.00	106.07
			7500	ECMA-F△1875□3	47.50	118.80	ASD-A2-7523-□	47.50	141.42
			11000	ECMA-F1221B□3	51.80	129.50	ASD-A2-1B23-□	54.40	141.42
			15000	ECMA-F1221F□S	61.50	145.70	ASD-A2-1F23-□	70.00	212.13

Motor						Servo Drive		
Motor series	Power	Output (W)	Model Number	Rated Current (Arms)	Max. Instantaneous current (Arms)	Model Number	Continuous Output Current (Arms)	Max. Instantaneous output current (Arms)
High Inertia ECMA-C/G 3000 r/min	Single- /Three- phase	400	ECMA-C Δ 0604 \square H	2.60	7.80	ASD-A2-0421- \square	2.60	7.80
		750	ECMA-C Δ 0807 \square H	5.10	15.30	ASD-A2-0721- \square	5.10	15.30
		300	ECMA-G Δ 1303 \square S	2.50	7.50	ASD-A2-0421- \square	2.60	7.80
		600	ECMA-G Δ 1306 \square S	4.80	14.40	ASD-A2-0721- \square	5.10	15.30
		900	ECMA-G Δ 1309 \square S	7.50	22.50	ASD-A2-1021- \square	7.30	21.90

Note:

1. The boxes (\square) at the ends of the servo drive model names are for optional configurations. For the actual model name, please refer to the ordering information of the actual purchased product.
2. The boxes (Δ) in the model names are for encoder resolution types. $\Delta=1$: Incremental type, 20-bit; $\Delta=2$: Incremental type, 17-bit; $\Delta=3$: 2500 ppr; $\Delta=A$: Absolute type). The listed motor model name is for information searching, please contact the local distributors for the actual purchased product.
3. The boxes (\square) in the model names represent brake or keyway / oil seal.
- 4 *11 kW and 15 kW will be available soon.

The above table shows the specification of the servo drive which has triple rated current. For detailed specification of the servo motor and servo drive, please refer to Chapter 11.

1.3.2 ASDA-A2 400V Series

		Motor				Servo Drive			
Motor series	Power	Output (W)	Model Number	Rated Current (Arms)	Max. Instantaneous current (Arms)	Model Number	Continuous Output Current (Arms)	Max. Instantaneous output current (Arms)	
Low Inertia	ECMA-J 3000 r/min	Three-phase	400	ECMA-J△0604□S	1.62	4.85	ASD-A2-0743-□	3.07	9.21
			750	ECMA-J△0807□S	3.07	9.5	ASD-A2-0743-□	3.07	9.21
			750	ECMA-J△0907□S	2.16	6.37	ASD-A2-0743-□	3.07	9.21
			1000	ECMA-J△0910□S	2.4	7.17	ASD-A2-1043-□	3.52	9.86
			1000	ECMA-J△1010□S	4.15	12.46	ASD-A2-1543-□	5.02	10.04
			2000	ECMA-J△1020□S	7.09	21.28	ASD-A2-2043-□	6.66	18.65
			3000	ECMA-J△1330□4	9.8	29.99	ASD-A2-3043-□	11.9	33.32
Medium Inertia	ECMA-K 2000 r/min	Three-phase	750	ECMA-K△1305□S	1.7	5.2	ASD-A2-0743-□	3.07	9.21
			1000	ECMA-K△1310□S	3.52	10.56	ASD-A2-1043-□	3.52	9.86
			1500	ECMA-K△1315□S	5.02	15.06	ASD-A2-1543-□	5.02	10.04
			2000	ECMA-K△1320□S	6.66	19.98	ASD-A2-2043-□	6.66	18.65
			2000	ECMA-K△1820□S	6.6	19.88	ASD-A2-2043-□	6.66	18.65
Medium-high Inertia	ECMA-L 1500 r/min	Three-phase	750	ECMA-L△1305□S	2.1	6.1	ASD-A2-0743-□	3.07	9.21
			850	ECMA-L△1308□S	3.4	8.85	ASD-A2-1043-□	3.52	9.86
			1300	ECMA-L△1313□S	5.02	15	ASD-A2-1543-□	5.02	10.04
			1800	ECMA-L△1318□S	11.2	30.4	ASD-A2-3043-□	11.9	33.32
			3000	ECMA-L△1830□S	11.53	34.6			
			4500	ECMA-L△1845□S	20.8	52	ASD-A2-4543-□	20	44
			5500	ECMA-L△1855□3	22.37	56	ASD-A2-5543-□	22.04	48.49
			7500	ECMA-L△1875□3	27.3	68.3	ASD-A2-7543-□	28.39	62.46
			11000	ECMA-L1221B□3	27.2	68	ASD-A2R-1B43-□	28.1	61.82
			15000	ECMA-L1221F□3	41.6	100	ASD-A2R-1F43-□	38.65	85.03
High Inertia	ECMA-C/G 3000 r/min ECMA-G 1000 r/min	Three-phase	900	ECMA-M△1309□S	4.4	13.1	ASD-A2-1543-□	5.02	10.04

Note:

1. The boxes (□) at the end of the servo drive model names are for optional configurations. For the actual model name, please refer to the ordering information of the actual purchased product.
2. The boxes (△) in the model names are for encoder resolution types. △= 1: Incremental type, 20-bit; △= 2: Incremental type, 17-bit; △= 3: 2500 ppr; △= A: Absolute type). The listed motor model name is for information searching, please contact your local distributors for the actual purchased product.
3. The boxes (□) in the model names represent brake or keyway / oil seal.

The above table shows the specification of the servo drive which has triple rated current. If you need the servo drive which specification is six times of the rated current of servo motor, contact the distributors. For detailed specification of the servo motor and servo drive, please refer to Chapter 11.

1.4 Each Part of the Servo Drive

1.4.1 ASDA-A2_220V Series

220V Series - Front View

Please see the figure of top view.

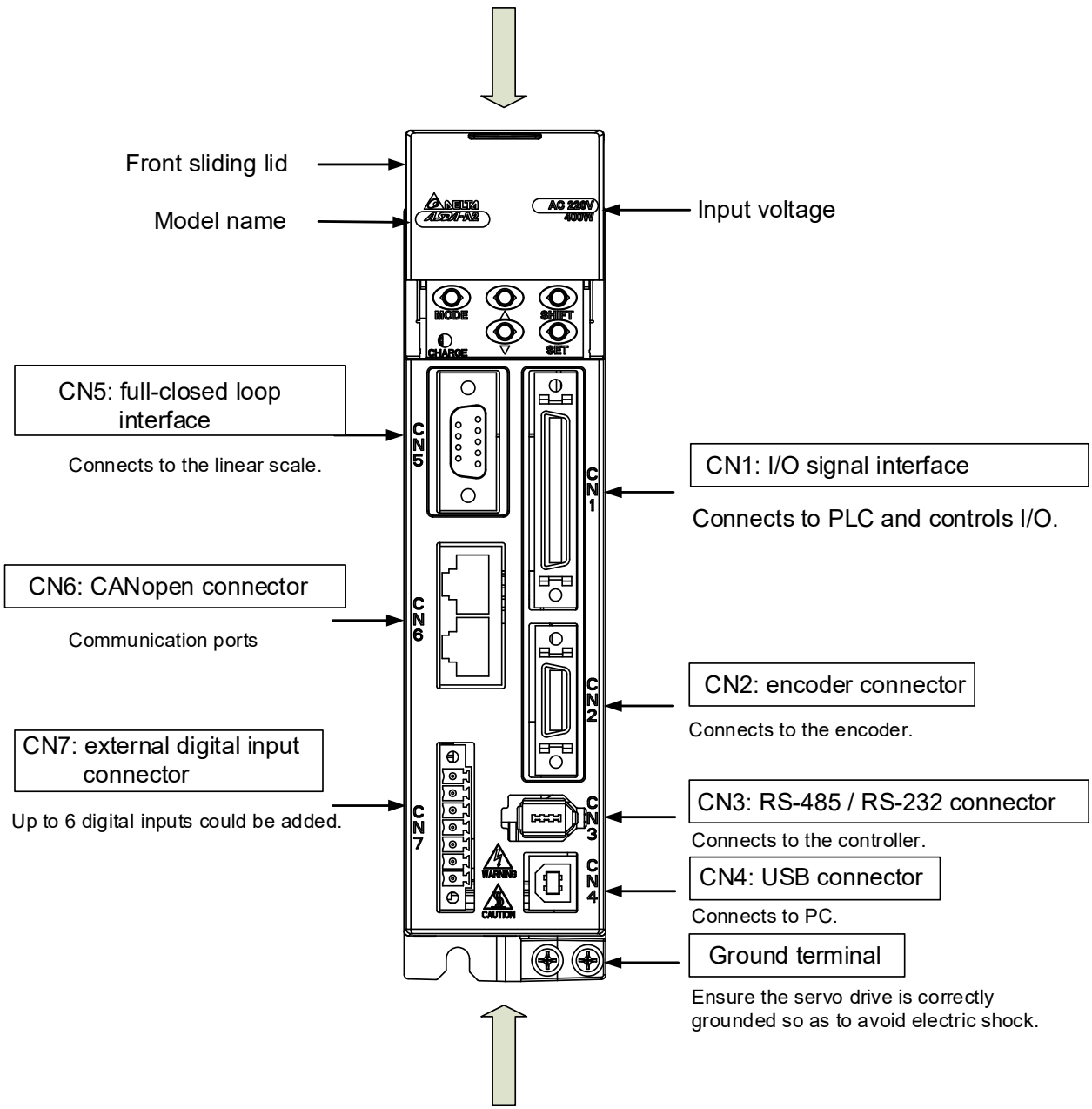

220V Series - Top View

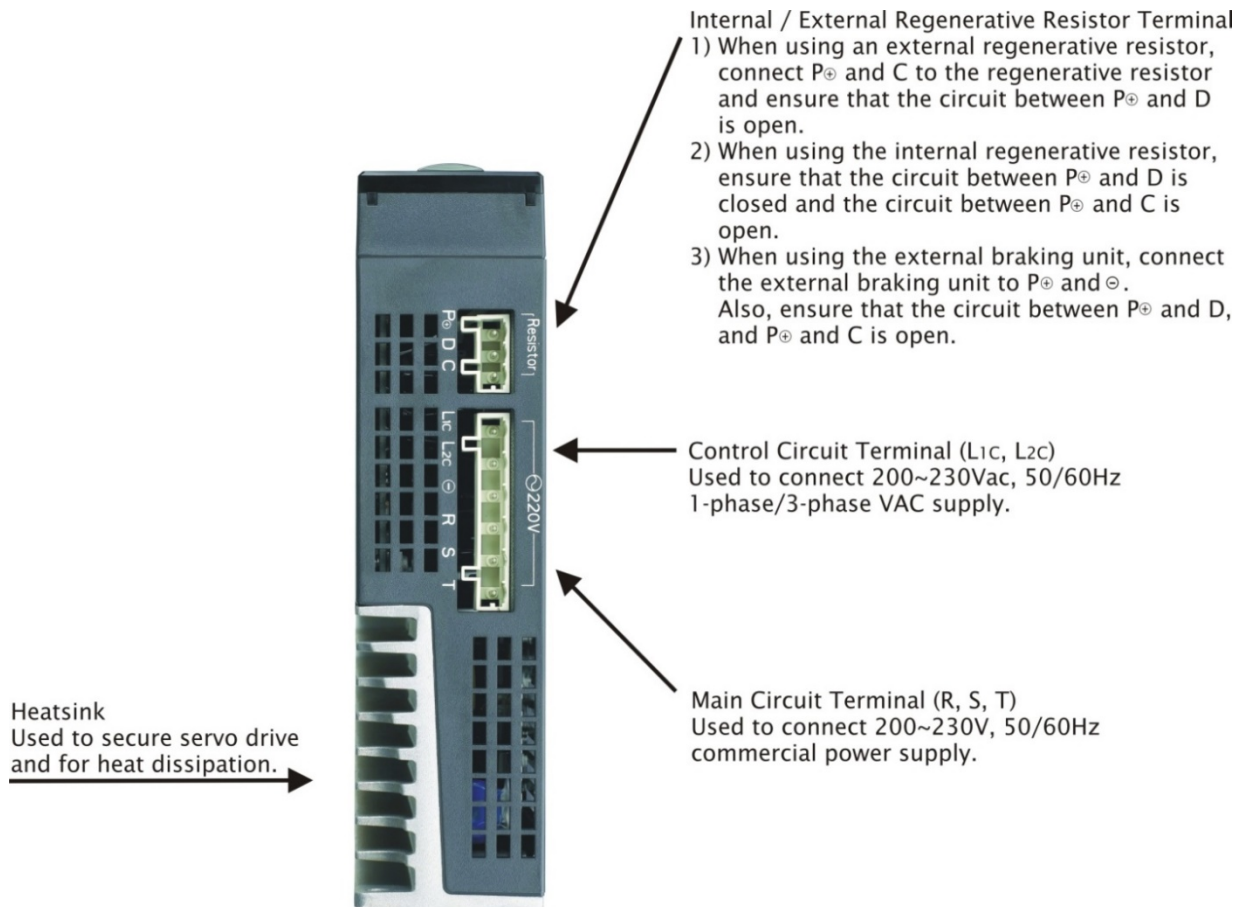

220V Series - Bottom View

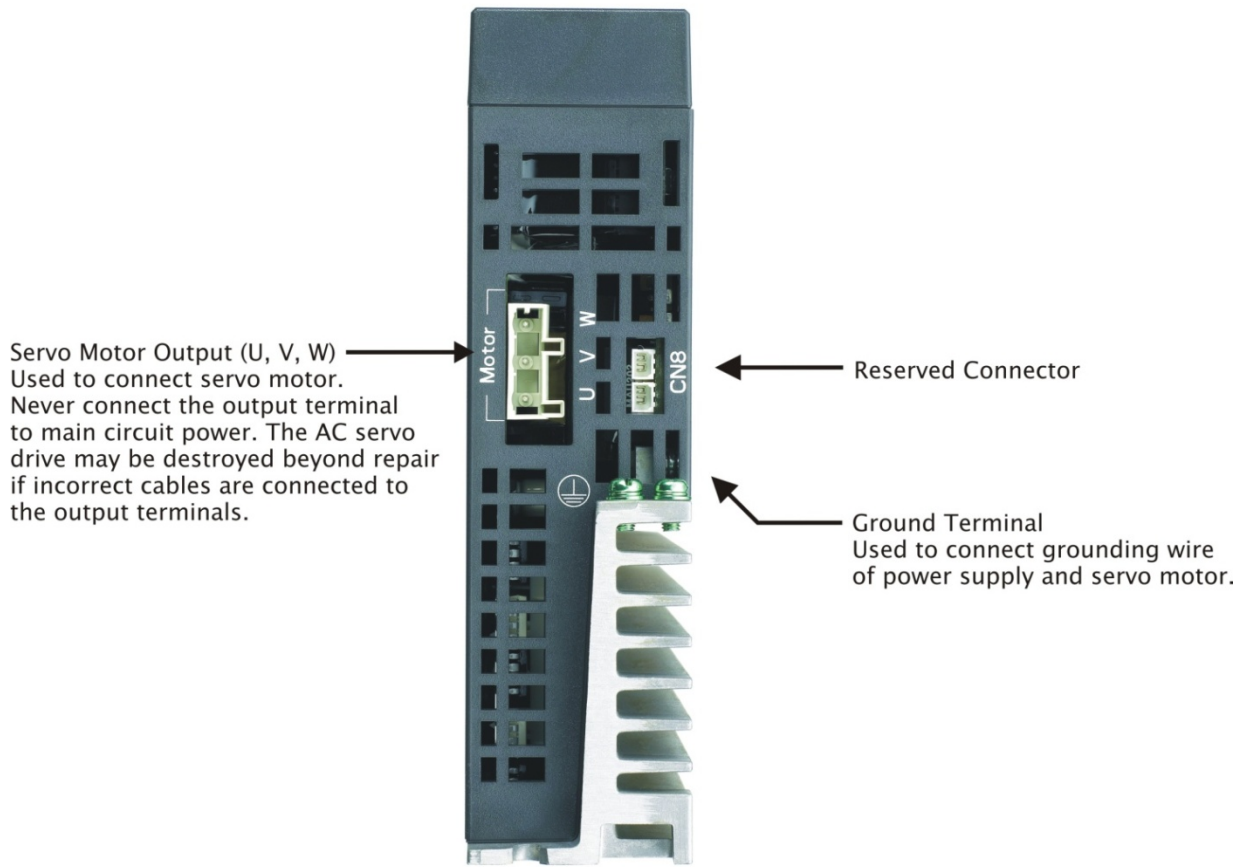

1.4.2 ASDA-A2_400V Series

400V Series - Front View

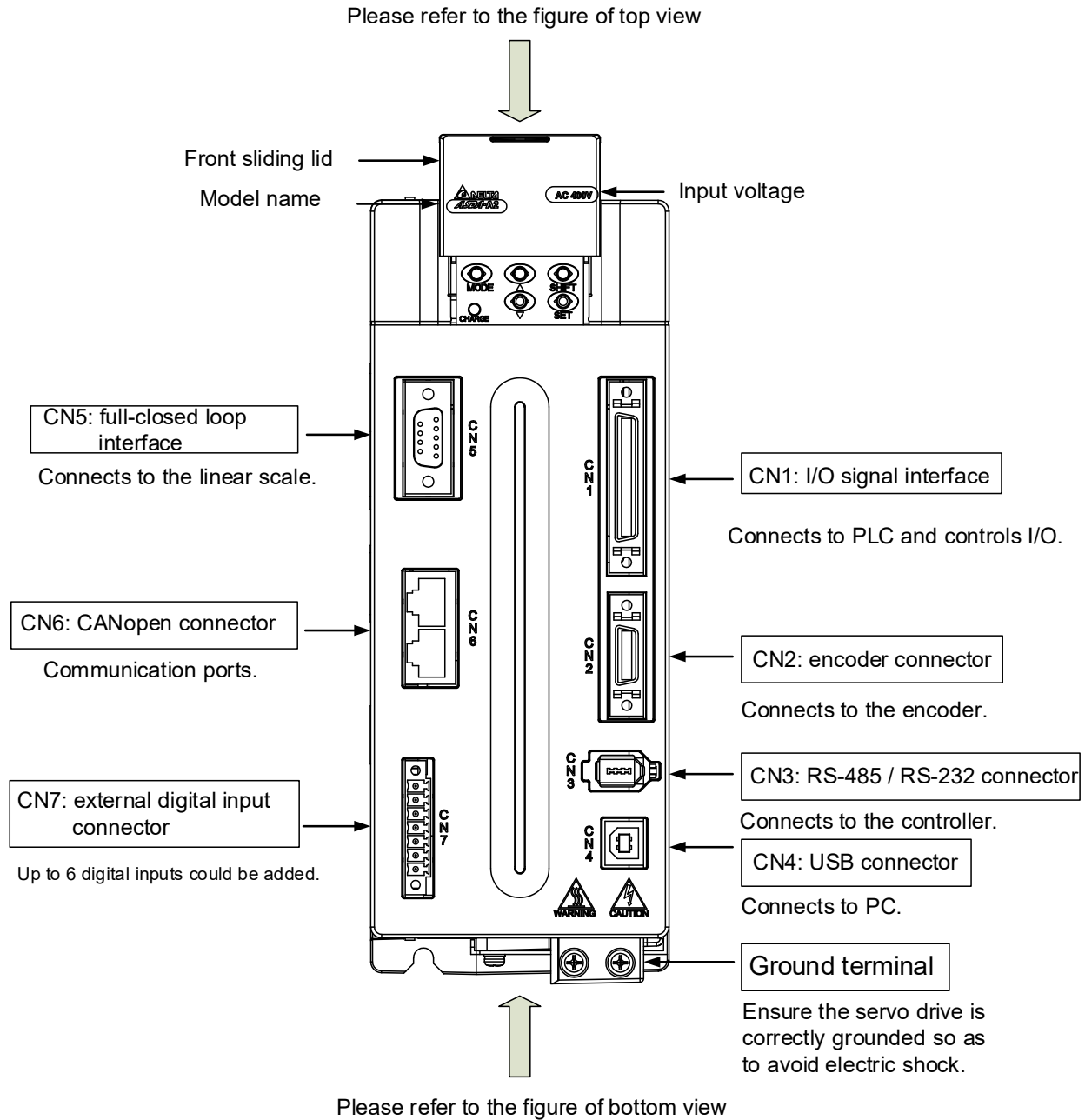

400V Series - Top View

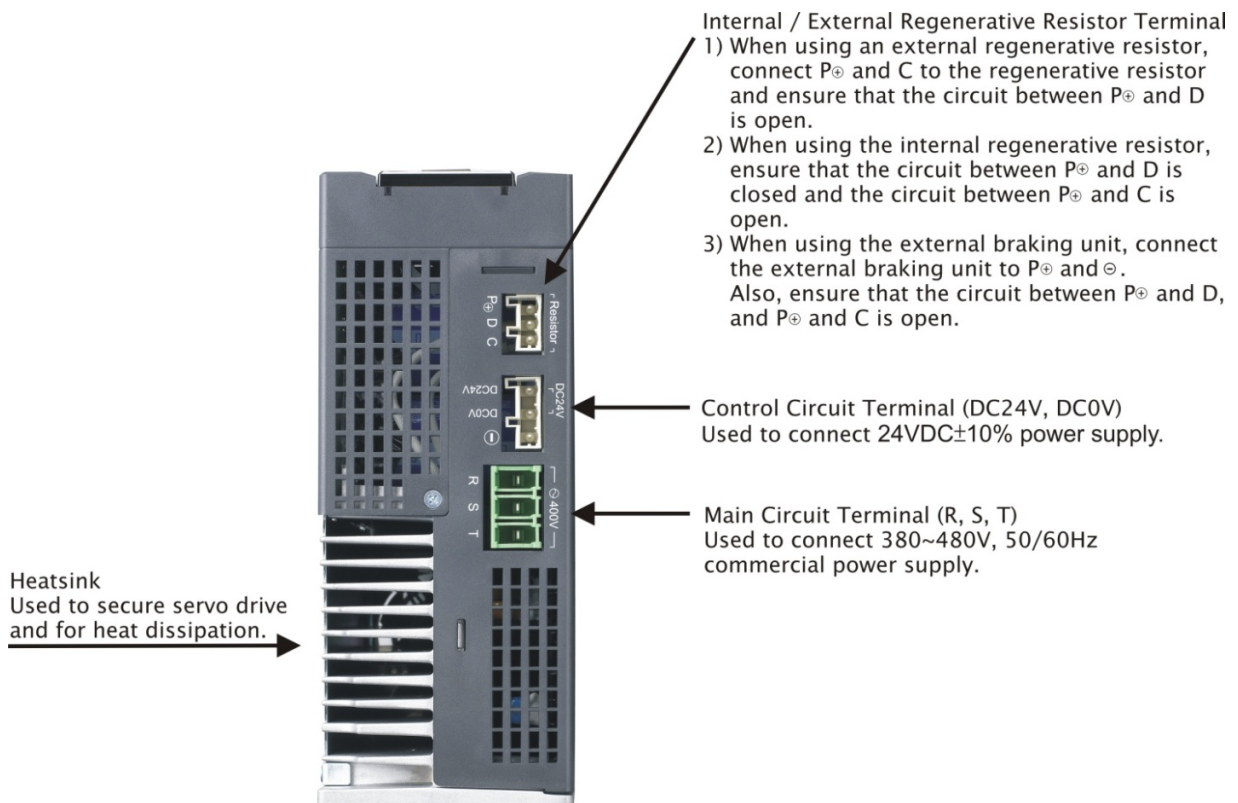

ASDA-A2_400V Series - Bottom View

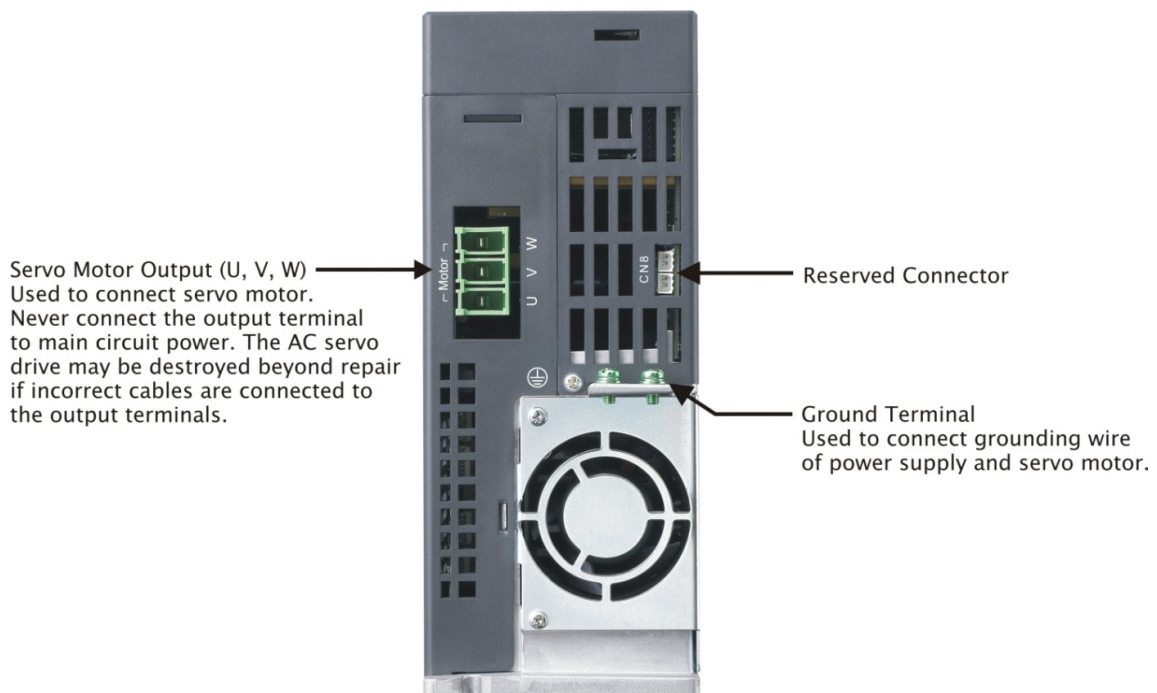

1.5 ASDA-A2-XN Series

1.5.1 Model Explanation

ASDA-A2-*N Series Servo Drive

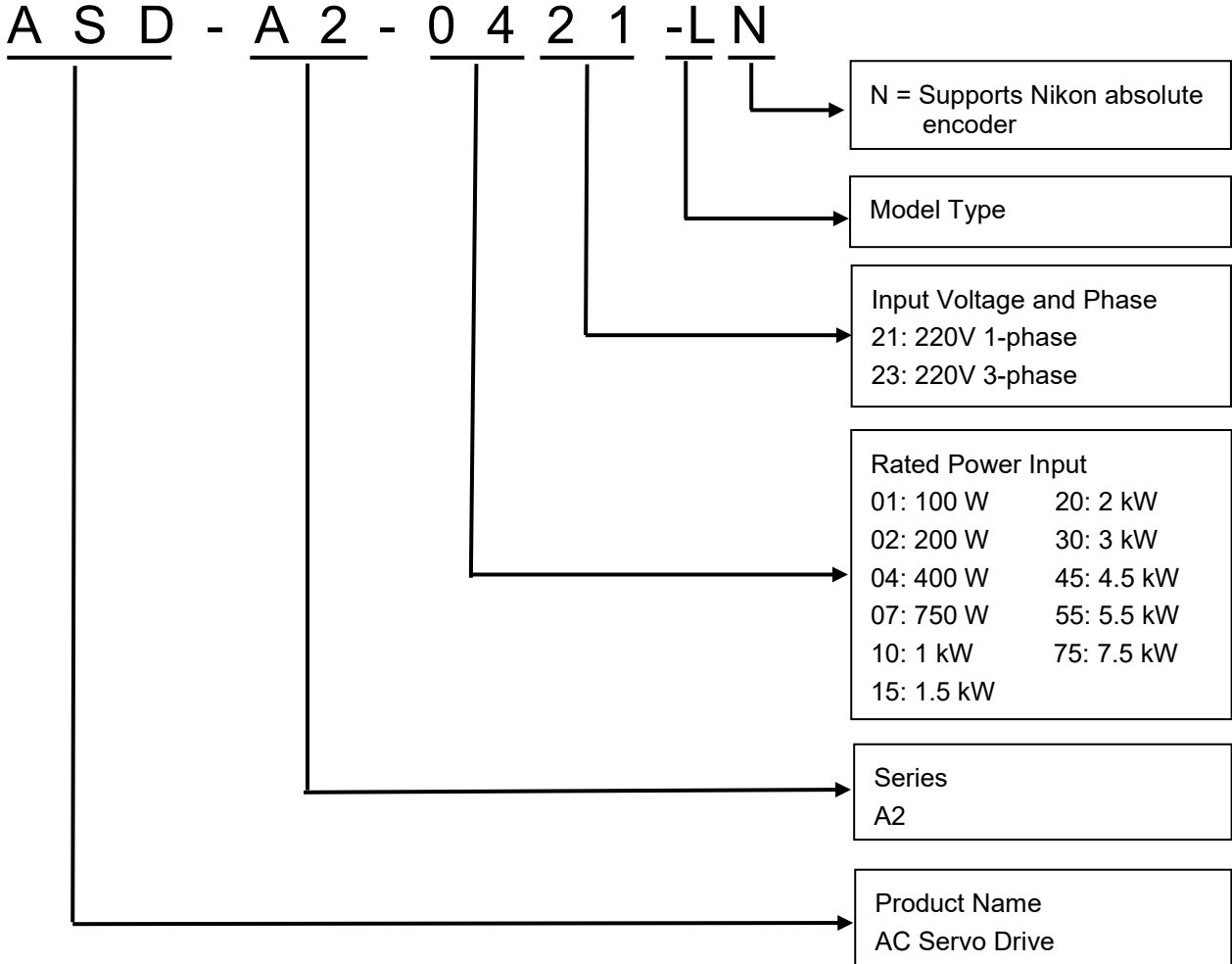

Model type

Type	Standard	Network 100 W ~ 3 kW			Network 4.5 kW ~ 7.5 kW		
A2 series	LN	EN	FN	MN	EN	FN	MN
RS-485 (CN3)	O	X	X	X	X	O	O
Full-closed loop control (CN5)	X	X	X	X	X	X	X
DI expansion port (CN7)	X	O	X	X	O	X	X
EtherCAT	X	O	X	X	O	X	X
CANopen	X	X	X	O	X	X	O
DMCNET	X	X	O	X	X	O	X
Analog voltage control	O	X	X	X	X	O	O
Pulse input	O	X	X	X	X	O	O
CN1 number of DI/DO	8/5	7/4	7/4	7/4	7/4	8/5	8/5
PR mode*1	O	O	O	O	O	O	O
E-Cam*2	X	O	X	O	O	X	O
STO*3	O	O	O	O	O	X	X

L: Full-closed loop E: EtherCAT F: DMCNET M: CANopen

Note:

1. You can only read PR parameters through communication in DMCNET mode.
2. E-Cam function is only applicable in PR mode.
3. STO certification application is in progress.

ECMC Series Servo Motor

E C M C - C W 0 6 0 2 R S

Standard Shaft Diameter: S
Specific Shaft Diameter: H = High Inertia

Type of Shaft Diameter and Oil Seal	w/o Brake, with Oil Seal	with Brake, with Oil Seal
Round Shaft (with fixed screw holes)	C	D
Keyway (with fixed screw holes)	R	S

Rated Power Output

01: 100 W	13: 1.3 kW
02: 200 W	15: 1.5 kW
04: 400 W	18: 1.8 kW
07: 750 W	20: 2.0 kW
08: 850 W	30: 3.0 kW
10: 1.0 kW	

Motor Frame Size

04: 40 mm	09: 86 mm	18: 180 mm
06: 60 mm	10: 100 mm	
08: 80 mm	13: 130 mm	

Series Name

Rated voltage and speed
C = 220V / 3,000 rpm; **E** = 220V / 2,000 rpm;
F = 220V / 1,500 rpm;

Encoder Type
W: absolute, 20-bit (resolution of single cycle: 20-bit; resolution of multi-cycle: 16-bit)
 Resolution of servo drive:
 1280000 p/rev

Driven Type

C: High Precision AC Servo Motor (applicable to CNC solutions)

Product Name

ECM: Electronic Commutation Motor

1.5.2 ASDA-A2-XN Series Servo Drive and Corresponding Motor

	Servo Drive	Corresponding Servo Motor
100 W	ASD-A2-0121-□N	ECMC-C [△] 0401□S (S = 8 mm)
200 W	ASD-A2-0221-□N	ECMC-C [△] 0602□S (S = 14 mm)
400 W	ASD-A2-0421-□N	ECMC-C [△] 0604□S (S = 14 mm) ECMC-C [△] 0804□7 (7 = 14 mm) ECMC-E [△] 1305□S (S = 22 mm) ECMC-G [△] 1303□S (S = 22 mm)
750 W	ASD-A2-0721-□N	ECMC-C [△] 0807□S (S = 19 mm) ECMC-C [△] 0907□S (S = 16 mm) ECMC-G [△] 1306□S (S = 22 mm)
1000 W	ASD-A2-1021-□N	ECMC-C [△] 0910□S (S = 16 mm) ECMC-C [△] 1010□S (S = 22 mm) ECMC-E [△] 1310□S (S = 22 mm) ECMC-G [△] 1309□S (S = 22 mm)
1500 W	ASD-A2-1521-□N	ECMC-E [△] 1315□S (S = 22 mm)
2000 W	ASD-A2-2023-□N	ECMC-C [△] 1020□S (S = 22 mm) ECMC-E [△] 1320□S (S = 22 mm) ECMC-E [△] 1820□S (S = 35 mm) *ECMC-F [△] 1313□S (S = 22 mm) *ECMC-F [△] 1318□S (S = 22 mm)
3000 W	ASD-A2-3023-□N	ECMC-E [△] 1830□S (S = 35 mm) ECMC-F [△] 1830□S (S = 35 mm) ECMC-C [△] 1330□8LA (8 = 28 mm)
4500 W	ASD-A2-4523-□N	ECMC-F [△] 1845□S (S = 35 mm) ECMC-C [△] 1340□PLA (P = 24 mm)
5500 W	ASD-A2-5523-□N	ECMC-F [△] 1855□3 (3 = 42 mm) ECMC-C [△] 1350□8LA (8 = 28 mm)
7500 W	ASD-A2-7523-□N	ECMC-F [△] 1875□3 (3 = 42 mm)

Note:

- at the end of the servo drive model name represents model type. For the actual model name, please refer to the ordering information of the actual purchased product.
- in the servo motor model name represents brake or keyway / oil seal.
- △ in the the servo model name represents encoder type.

* represents high inertia motor.

The above table shows the specification of servo drive which has triple rated current. For detailed specification of the servo motor and servo drive, please refer to Chapter 11.

1.5.3 Each Part of the ASDA-A2-XN Series Servo Drive

Servo drive models (front view)

The last two codes in the end of the servo drive model name represent the model type. The product front views are as follows; the servo drive appearances are subject to change with models of different input power. Please refer to the actual product.

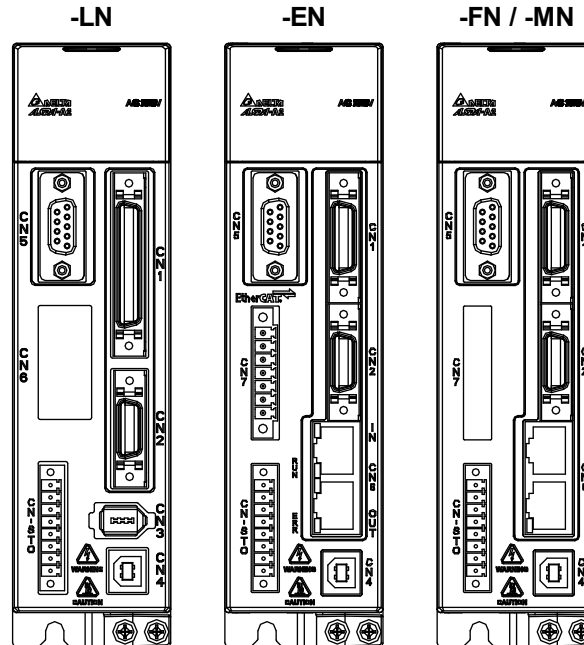

Connector	Function	Description
CN1	Input / Output Signal Connector	Connects to PLC or control I/O 50-pin: applicable to -LN series and 4.5 kW ~ 7.5 kW models of -FN and -MN series 26-pin: applicable to -EN series and models below 3 kW of -FN and -MN series
CN2	Encoder Connector	Connects to the encoder connector on the motor
CN3	RS-485 Connector	Connects to controller (only applicable to -LN models)
CN4	USB Connector	Connects to the PC
CN5	Full-closed Connector	Connects to the linear scale
CN6	Communication Connector	Connector for communication control (only applicable to -EN, -FN, and -MN models) *Communication connector function: CANopen: applicable to -MN models DMCNET: applicable to -FN models EtherCAT: applicable to -EN models
CN7	External DI Connector	7 expandable DI points (only applicable to -EN models)
CN8	Absolute Encoder Battery Connector	Connects to the battery connector on the absolute encoder cable
CN-STO	CN-STO	Safe Torque Off

Servo Drive (top view)

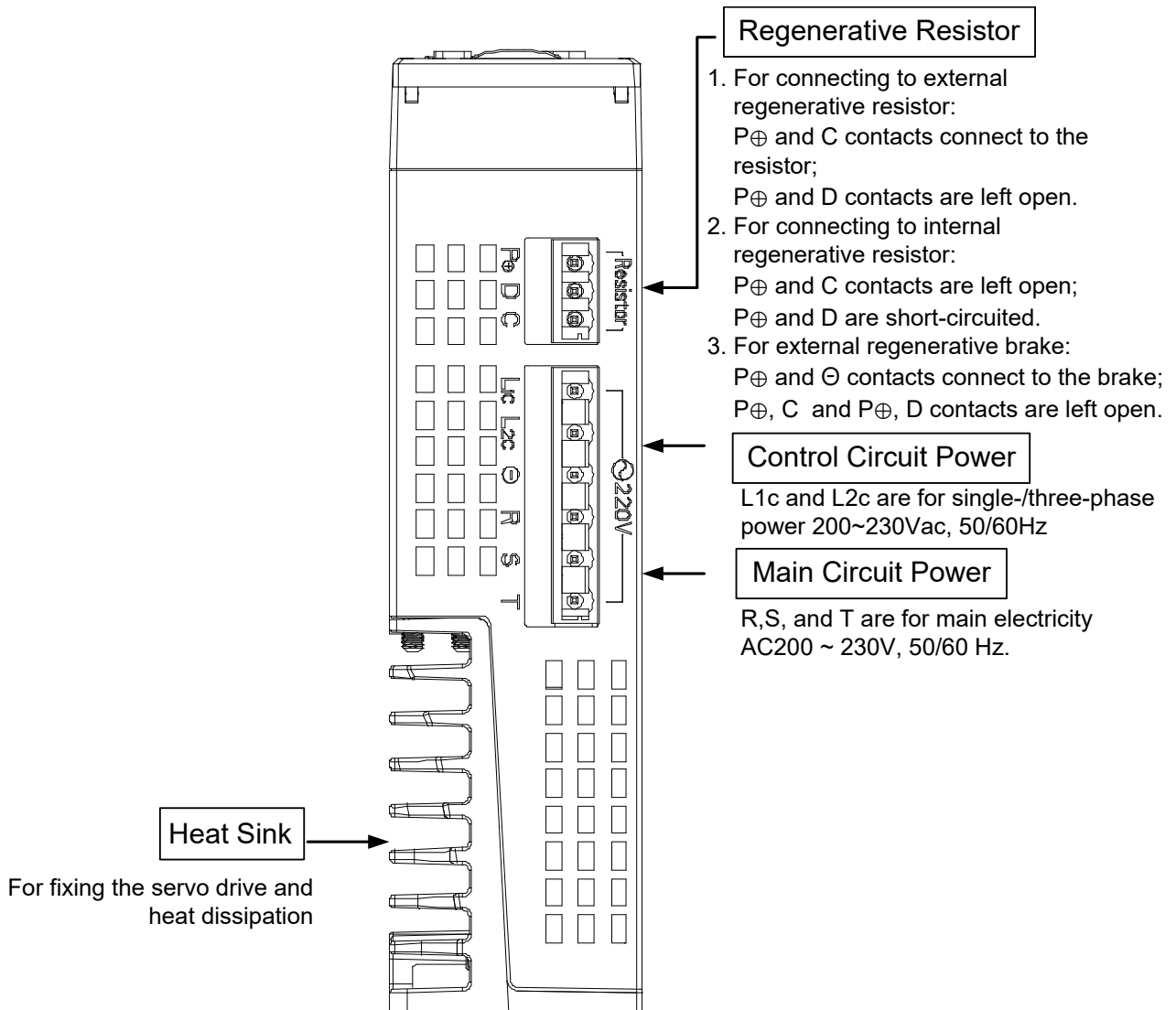

Servo Drive (bottom view)

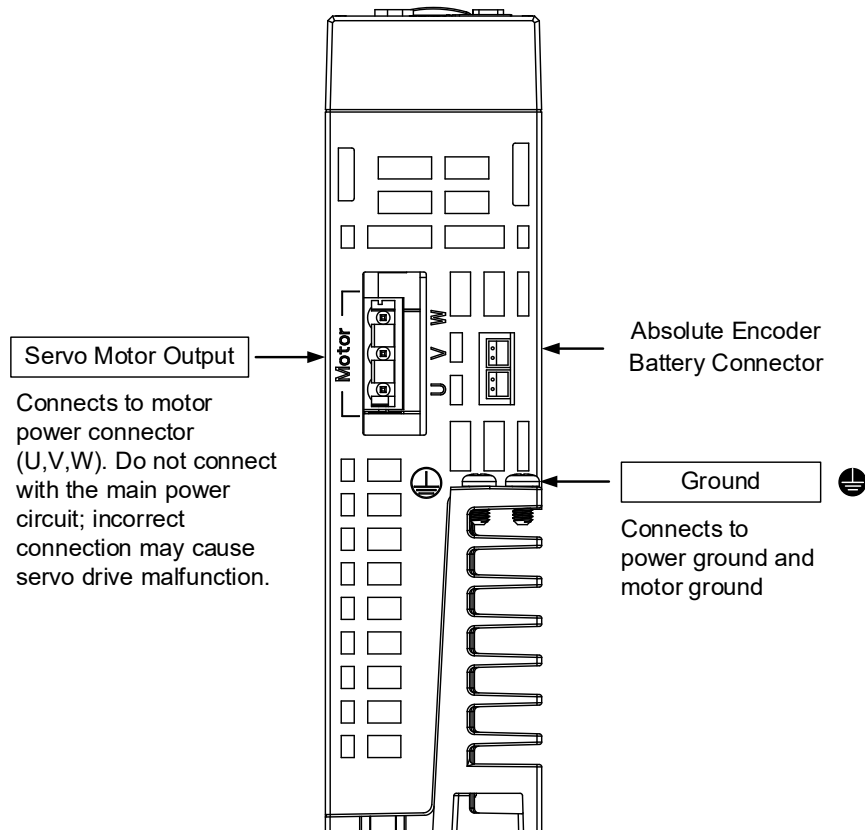

Chapter 2 Installation

2.1 Notes

Please pay special attention to the followings:

- If the connection between the servo drive and the servo motor is over 20 meters (65.62 feet), please thicken the connecting wire, UVW, as well as the encoder cable. Please refer to Section 3.1.6 for further information.

2.2 Ambient Conditions of Storage

Before the installation, this product has to be kept in the shipping carton. In order to retain the warranty coverage and for the maintenance, please follow the instructions below for storage, if the product is not in use temporarily:

- Store the product within an ambient temperature range of -20°C to $+65^{\circ}\text{C}$ (-4°F to 149°F).
- Store the product within a relative humidity range of 0% to 90% and a non-condensing environment.
- Avoid storing the product in the environment containing corrosive gas and liquid.

2.3 Ambient Conditions of Installation

The ambient conditions of installing and operating the servo drive:

A location that has no over-heat device, no water drop, vapor, dust and oily dust, no corrosive and inflammable gas and liquid, no airborne dust and metal particles, no interference of electromagnetic noise and has solid foundation and no vibration.

The ambient conditions of operating the servo motor:

The ambient temperature is between 0°C and 40°C (32°F to 104°F). And the ambient location shall have no over-heat device, no water drop, vapor, dust and oily dust, no corrosive and inflammable gas and liquid, no airborne dust and metal particles.

The best temperature of this servo drive is between 0°C and 55°C (32°F to 131°F). If the temperature is over 45°C (113°F), please place the product in a well-ventilated environment so as to ensure its performance. If the product is installed in a distribution board, make sure the size of the distribution board and its ventilation condition will not overheat and endanger the internal electronic device. Also, pay attention to the vibration of the machine. Check if the vibration will influence the electronic device of the electric box.

2.4 Installation Direction and Space

Notes:

- Mount the servo drive according to the following illustration. Incorrect installation may result in a drive malfunction or premature failure of the drive and motor.
- The ASDA-A2 servo drive should be mounted perpendicularly to the wall or in the control panel. In order to ensure the drive is well ventilated, ensure that all ventilation holes are not obstructed and sufficient free space is given to the servo drive. Do not install the drive in a horizontal position or malfunction and damage will occur.
- Do not connect the servo drives in parallel, or it might burn out the soft-start resistance or the commutator and cause danger.

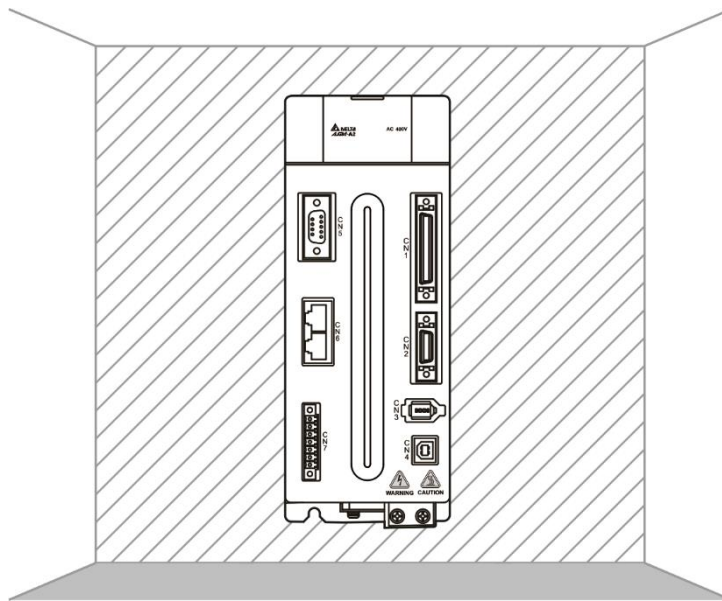

Correct

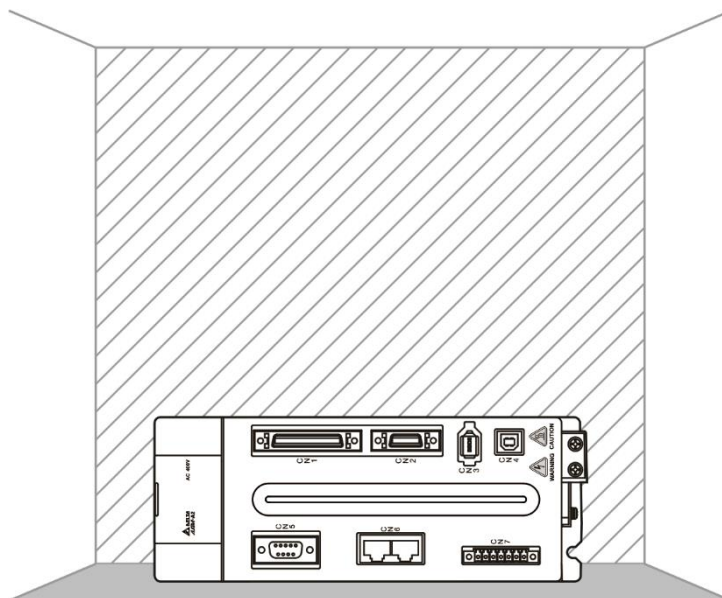

Incorrect

Scheme of Installation:

In order to have smaller wind resistance of the fan and increase the ventilation, please follow the suggested clearance value when installing one or more than one servo drives. (Refer to the following diagram.)

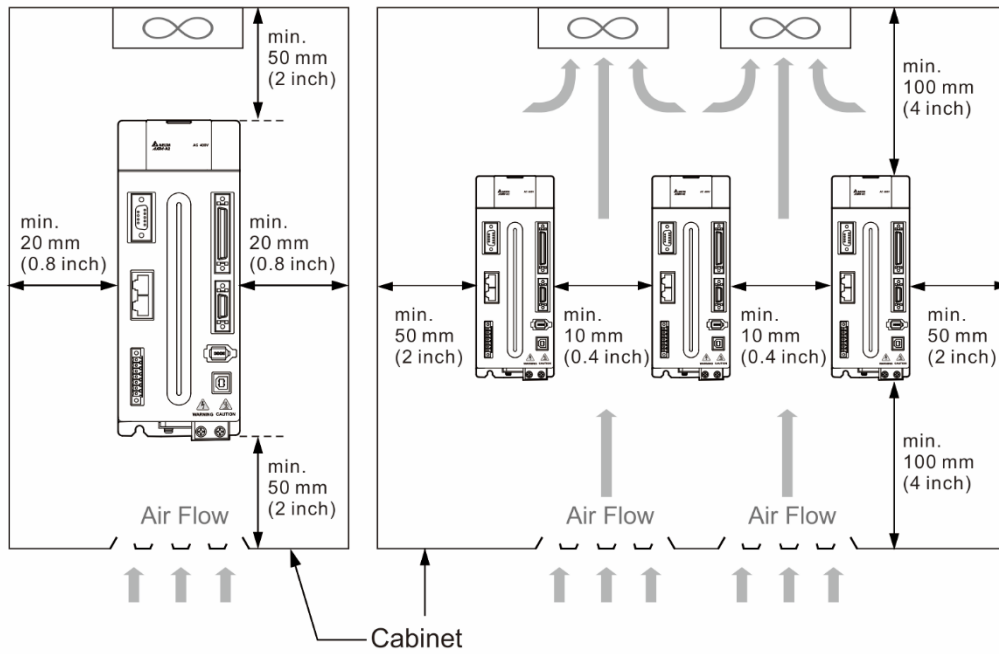

Note: The above diagrams are not in equal proportion. Please refer to the annotation.

2.5 Specification of Circuit Breaker and Fuse

220V Series

Caution: Please use the fuse and circuit breaker that are recognized by UL / CSA.

Servo Drive Model	Circuit Breaker	Fuse (Class T)
Operation Mode	General	General
ASD-A2-0121-□	5A	5A
ASD-A2-0221-□	5A	5A
ASD-A2-0421-□	10A	10A
ASD-A2-0721-□	10A	20A
ASD-A2-1021-□	15A	25A
ASD-A2-1521-□	20A	40A
ASD-A2-2023-□	30A	50A
ASD-A2-3023-□	30A	70A
ASD-A2-4523-□	70A	140A
ASD-A2-5523-□	75A	150A
ASD-A2-7523-□	95A	175A
ASD-A2-1B23-□	-	-
ASD-A2-1F23-□	-	-

Note: If the servo drive equips with earth leakage circuit breaker for avoiding electric leakage, please choose the current sensitivity which is over 200 mA and can continue up to 0.1 seconds.

400V Series

Caution: Please use the fuse and circuit breaker that are recognized by UL / CSA.

Servo Drive Model	Circuit Breaker	Fuse (Class T)
Operation Mode	General	General
ASD-A2-0443-□	10A	10A
ASD-A2-0743-□	10A	15A
ASD-A2-1043-□	15A	20A
ASD-A2-1543-□	20A	25A
ASD-A2-2043-□	25A	30A
ASD-A2-3043-□	30A	50A
ASD-A2-4543-□	50A	80A
ASD-A2-5543-□	60A	90A
ASD-A2-7543-□	70A	120A
ASD-A2R-1B43-□	100A	150A
ASD-A2R-1F43-□	125A	200A

Note: If the servo drive equips with earth leakage circuit breaker for avoiding electric leakage, please choose the current sensitivity which is over 200 mA and can continue up to 0.1 seconds.

2.6 Ferrite Ring

The movable or round-shaped ferrite ring is usually made of Mn-Zn ferrite. The impedance of the ferrite ring varies with frequency. Normally, its impedance is relatively small to a low-frequency signal; however, when the frequency of the signal increases, the impedance may increase dramatically. Use the ferrite ring to optimize signal transmission and suppress high-frequency noise, and reduce high-frequency interference in the power cable, signal cable, and connectors.

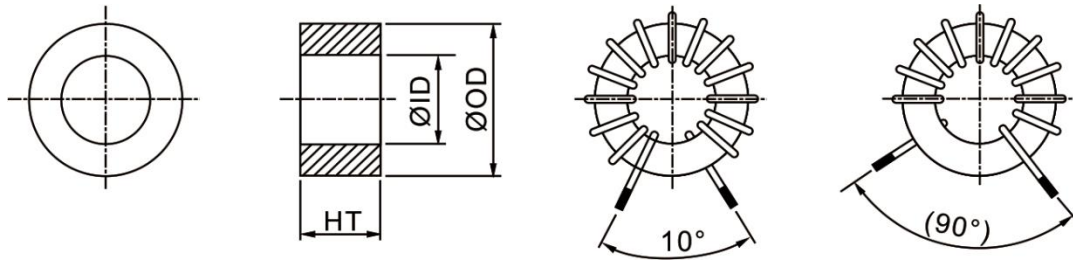

UNIT: mm (inch)

Model	OD	ID	HT	Winding Condition	Inductance L (OA)	Initial Permeability
ASD-ACFC7K00	68.0 ± 0.6	44.0 ± 0.6	13.5 ± 0.5	Ø0.5 2UEW 20TS	2.6 mH ± 25%	5500

Ferrite ring model	Applicable servo drive model
ASD-ACFC7K00	ASD-A2-4523-□, ASD-A2-5523-□, ASD-A2-7523-□, ASD-A2-1B23-□, ASD-A2-1F23-□
	ASD-A2-2043-□, ASD-A2-3043-□, ASD-A2-4543-□, ASD-A2-5543-□, ASD-A2-7543-□, ASD-A2-1B43-□, ASD-A2-1F43-□

Installation precautions

The ferrite ring is commonly used when peripheral devices (such as a controller) are affected by noise from conduction and radiation when the servo motor is in the Servo On state. The parasitic capacitance between the cables in the wiring panel and the ground is typically small. As the frequency of the signal increases (Servo On state), the resistance of the parasitic capacitance becomes small enough to let common-mode current flow through. Normally, common-mode current only leads to common-mode interference due to an unstable circuit caused by a poor connection between the power circuit and ground. If the common-mode current flows through the external cables, common-mode interference may also happen due to electrical interference caused by unstable electric potential.

The ferrite ring causes eddy current losses to a high-frequency signal and transforms it into heat when suppressing common-mode interference. The ferrite ring acts as a low-pass filter to effectively suppress high-frequency noise and ensure the stability of the circuit while the impedance to low-frequency signals is relatively small.

Winding several turns of wire onto the ferrite ring can increase inductance and the ability to filter out high-frequency noise.

The suggested winding methods are shown below:

1. For A2-220V model (4.5 kW ~ 7.5 kW) and A2-400V model (2 kW ~ 7.5 W)

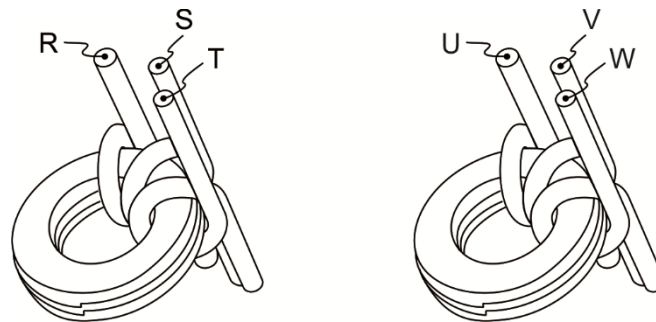

- For A2-220V model (11 kW ~ 15 kW) and A2-400V model (11 kW ~ 15 kW)

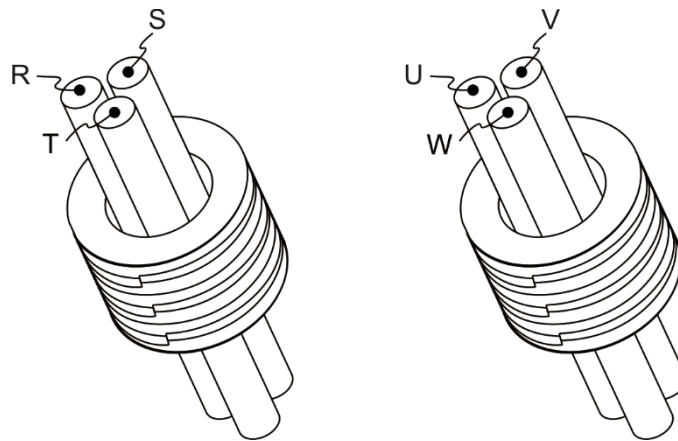

Note:

- Please refer to Section 3.1.4 for the selection of the motor power cable.
- Only the motor power cable or power cable can run through the ferrite ring. If needed, please prepare extra ferrite rings for grounding.
- An EMI filter may be required for absorbing radiation when using a longer motor power cable.

2.7 EMI Filter Selection

220V Series

Item	Power	Servo Drive Model	Recommended EMI Filter		FootPrint
			1PH	3PH	
1	100 W	ASD-A2-0121-□	RF007S21AA	RF022B43AA	N
2	200 W	ASD-A2-0221-□	RF007S21AA	RF022B43AA	N
3	400 W	ASD-A2-0421-□	RF007S21AA	RF022B43AA	N
4	750 W	ASD-A2-0721-□	RF007S21AA	RF037B43BA	N
5	1.0 kW	ASD-A2-1021-□	RF007S21AA	RF037B43BA	N
6	1.5 kW	ASD-A2-1521-□	RF007S21AA	RF037B43BA	N
7	2.0 kW	ASD-A2-2023-□	-	RF037B43BA	N
8	3.0 kW	ASD-A2-3023-□	-	RF037B43BA	N
9	4.5 kW	ASD-A2-4523-□	-	RF075M43BA	N
10	5.5 kW	ASD-A2-5523-□	-	RF075M43BA	Y
11	7.5 kW	ASD-A2-7523-□	-	30TDRT1W4	Y
12	11.0 kW	ASD-A2-1B23-□	-	50TDS4W4C	-
13	15.0 kW	ASD-A2-1F23-□	-	50TDS4W4C	-

400V Series

Item	Power	Servo Drive Model	Recommended EMI Filter	FootPrint
1	750 W	ASD-A2-0743-□	RF007S43AA	N
2	1000 W	ASD-A2-1043-□	RF007S43AA	N
3	1500 W	ASD-A2-1543-□	RF022B43AA	N
4	2000 W	ASD-A2-2043-□	RF037B43BA	N
5	3000 W	ASD-A2-3043-□	RF037B43BA	N
6	4500 W	ASD-A2-4543-□	RF075M43BA	N
7	5500 W	ASD-A2-5543-□	RF075M43BA	Y
8	7500 W	ASD-A2-7543-□	RF075M43BA	Y
9	11 kW	ASD-A2-1B43-□	KMF370A	-
10	15 kW	ASD-A2-1F43-□	KMF370A	-

EMI Filter Installation

All electronic equipment (including servo drive) generates high or low frequency noise during operation and interferes with the peripheral equipment via conduction or radiation. With an EMI Filter and the correct installation, much interference can be eliminated. It is suggested to use Delta's EMI Filter to suppress the interference better.

When installing the servo drive and EMI Filter, please follow the instructions of the user manual and make sure it meets the following specifications:

1. EN61000-6-4 (2001)
2. EN61800-3 (2004) PDS of category C2
3. EN55011+A2 (2007) Class A Group 1

General Precaution

In order to ensure the best performance of EMI Filter, apart from the instructions of servo drive installation and wiring, please follow the precautions below:

1. The servo drive and EMI Filter should be installed on the same metal plate.
2. When installing the servo drive and EMI Filter, the servo drive should be installed above the EMI Filter.
3. The wiring should be as short as possible.
4. The metal plate should be well grounded.
5. The metal cover of the servo drive and EMI Filter or grounding should be firmly fixed on the metal plate. Also, the contact area should be as large as possible.
6. It is suggested to install one servo drive with one EMI filter.

Motor Cable Selection and Installation Precautions

The selection of motor cables and installation affects the performance of EMI Filter. Please follow the precautions below.

1. Use the cable that has braid shielding. (The effect of double shielding is better.)
2. The shield on both sides of the motor cable should be grounded in the shortest distance and the largest contact area.
3. The protective paint of the U-shape saddle and metal plate should be removed in order to ensure good contact. Please see the figure below.
4. It should have a correct connection between the braid shielding of the motor cable and the metal plate. The braid shielding on both sides of the motor cable should be fixed by the U-shape saddle and metal plate. Please see the figure below for the correct connection.

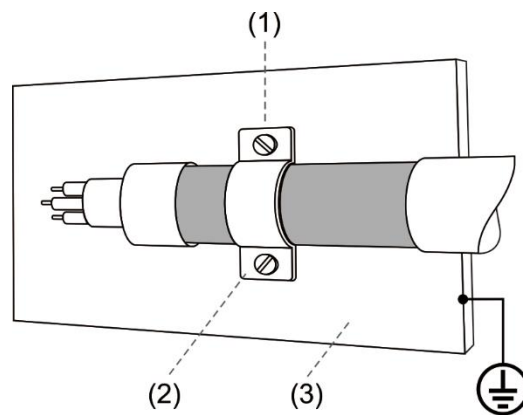

- (1) The protective paint of the U-shape saddle and metal plate should be removed in order to ensure good contact.
- (2) U-shape saddle
- (3) Well-grounded metal plate

2.8 Selection of Regenerative Resistor

When the direction of pull-out torque is different from the rotation, it means the electricity is sent back to the servo drive from the load-end. It becomes the capacitance of DC Bus and increases the voltage. When the voltage increases to a specific value, the come-back electricity can only be consumed by regenerative resistor. There is a built-in regenerative resistor in the servo drive. Users can also use the external regenerative resistor if needed.

Specification of built-in regenerative resistor provided by ASDA-A2 220V Series

Servo Drive (kW)	Specification of built-in regenerative resistor		The capacity of built-in regenerative resistor (Watt)	Minimum allowable resistance (Ohm)
	Resistance (P1-52) (Ohm)	Capacity (P1-53) (Watt)		
0.1	-	-	-	30
0.2	-	-	-	30
0.4	40	40	20	30
0.75	40	60	30	20
1.0	40	60	30	20
1.5	40	60	30	20
2.0	20	100	50	10
3.0	20	100	50	10
4.5	20	100	50	10
5.5	-	-	-	8
7.5	-	-	-	5
11	-	-	-	8
15	-	-	-	5

Specification of built-in regenerative resistor provided by ASDA-A2 400V Series

Servo Drive (kW)	Specification of built-in regenerative resistor		Minimum allowable resistance (Ohm)
	Resistance (P1-52) (Ohm)	Capacity (P1-53) (Watt)	
0.75	80	100	60
1.0	80	100	60
1.5	80	100	40
2.0	-	-	40
3.0	-	-	30
4.5	-	-	20
5.5	-	-	20
7.5	-	-	15
11	-	-	15
15	-	-	15

When the regenerative energy exceeds the capacity of the built-in regenerative resistor, the external regenerative resistor should be applied. Please pay special attention to the followings when using the regenerative resistor.

1. Please correctly set up the resistance (P1-52) and capacity (P1-53) of regenerative resistor. Or it might influence the performance of this function.
2. When using an external regenerative resistor, please note that its resistance must be greater than the resistance of the built-in regenerative resistor. For general application, you can connect more than one resistor in series. If the value (from resistors connected in series) exceeds the rated range, you can reduce the value by connecting the resistor in parallel. If you want to connect the resistors in parallel to increase the power of the regenerative resistor, please make sure the capacitance meets the requirements.

See the following diagram and settings for connecting the regenerative resistor in serial and parallel.

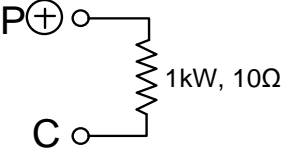
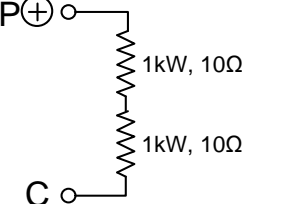
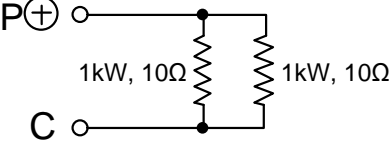
<p>External Regenerative Resistor</p> 	<p>Setting: P1-52=10 (Ω) P1-53=1000 (W)</p>
<p>External Regenerative Resistor (serial connection)</p> 	<p>Setting: P1-52=20 (Ω) P1-53=2000 (W)</p>
<p>External Regenerative Resistor (parallel connection)</p> 	<p>Setting: P1-52=5 (Ω) P1-53=2000 (W)</p>

3. In natural environment, if the capacity of the regenerative resistor (the average value) is within the rated capacity, the temperature of the capacitance will increase to 120°C (248°F) or even higher (under the condition of regenerative energy continues to function). For safety concerns, please apply the method of forced cooling in order to reduce the temperature of regenerative resistor. Or, it is suggested to use the regenerative resistor which is equipped with thermal switches. Please contact the distributors for load characteristics of the regenerative resistor.

When using the external regenerative resistor, the resistor should connect to P, C terminal and the contact of P, D terminal should be opened. It is recommended to choose the above mentioned capacitance. For easy calculation of regenerative resistor capacity, except the energy consumed by IGBT, two ways are provided to select the capacity of the external regenerative resistor according to the selected linear motor or rotary motor.

(1) Regenerative Power Selection

(a) When the external load on torque does not exist

If the motor operates back and forth, the energy generated by the brake will go into the capacitance of DC bus. When the voltage of the capacitance exceeds a specific value, the redundant energy will be consumed by the regenerative resistor. Two ways of selecting the regenerative resistor are provided here. The table below provides the energy calculation method. Users can refer to it and calculate the selected regenerative resistor.

220V

Servo Drive (kW)	Motor	Rotor Inertia J ($\times 10^{-4}\text{kg.m}^2$)	Regenerative power from empty load 3000 r/min to stop Eo (joule)	The maximum regenerative power of capacitance Ec (joule)
Low Inertia	0.1 ECMA-C Δ 040F□□	0.021	0.10	4.21
	0.1 ECMA-C Δ 0401□□	0.037	0.18	4.21
	0.2 ECMA-C Δ 0602□□	0.177	0.87	5.62
	0.4 ECMA-C Δ 0604□□	0.277	1.37	8.42
	0.4 ECMA-C Δ 0804□□	0.68	3.36	8.42
	0.75 ECMA-C Δ 0807□□	1.13	5.59	17.47
	0.75 ECMA-C Δ 0907□□	1.93	9.54	17.47
	1.0 ECMA-C Δ 1010□□	2.65	13.10	21.22
	1.0 ECMC-C Δ 0910□□	2.62	12.96	21.22
	2.0 ECMA-C Δ 1020□□	4.45	22.0	25.58
3.0 ECMA-C Δ 1330□□	12.7	62.80	25.58	
Medium Inertia	0.4 ECMA-E Δ 1305□□	8.17	40.40	8.42
	1.0 ECMA-E Δ 1310□□	8.41	41.59	21.22
	1.5 ECMA-E Δ 1315□□	11.18	55.29	25.58
	2.0 ECMA-E Δ 1320□□	14.59	72.15	25.58
	2.0 ECMA-E Δ 1820□□	34.68	171.49	25.58
	3.0 ECMA-E Δ 1830□□	54.95	271.73	31.20
3.0 ECMA-E Δ 1835□□	54.95	271.73	31.20	
Medium-High Inertia	1.0 ECMA-F Δ 1308□□	13.6	67.25	21.22
	2.0 ECMA-F Δ 1313□□	20.0	98.90	25.58
	2.0 ECMA-F Δ 1318□□	24.9	123.13	31.20
	3.0 ECMA-F Δ 1830□□	54.95	271.73	28
	4.5 ECMA-F Δ 1845□□	77.75	384.48	25
	5.5 ECMA-F Δ 1855□□	99.78	493.42	27
7.5 ECMA-F Δ 1875□□	142.7	705.66	93	

Servo Drive (kW)		Motor	Rotor Inertia J ($\times 10^{-4}$ kg.m ²)	Regenerative power from empty load 3000 r/min to stop Eo (joule)	The maximum regenerative power of capacitance Ec (joule)
Medium-High Inertia	11.0	ECMA-F Δ 221B□□	329.0	723.08	117
	15.0	ECMA-F Δ 221F□□	553.0	1215.38	156
High Inertia	0.4	ECMA-G Δ 1303□□	8.17	17.96	8.42
	0.75	ECMA-F Δ 1305□□	10.3	22.64	17.47
	0.75	ECMA-G Δ 1306□□	8.41	18.48	17.47
	1.0	ECMA-G Δ 1309□□	11.18	24.57	21.22

$E_o = J \cdot \omega^2 / 182$ (joule), ω : r/min

400V

Servo Drive (kW)		Motor	Rotor Inertia J ($\times 10^{-4}$ kg.m ²)	Regenerative power from empty load 3000 r/min to stop Eo (joule)	The maximum regenerative power of capacitance Ec (joule)
Low Inertia	0.75	ECMA-J Δ 0604□□	0.277	1.37	42.43
	0.75	ECMA-J Δ 0807□□	1.13	5.59	42.43
	0.75	ECMA-J Δ 0907□□	1.93	9.54	42.46
	1.0	ECMA-J Δ 0910□□	2.62	12.96	42.43
	1.5	ECMA-J Δ 1010□□	2.65	13.10	42.43
	2.0	ECMA-J Δ 1020□□	4.45	22.01	42.43
Medium Inertia	0.75	ECMA-K Δ 1305□□	8.17	40.40	51.17
	1.0	ECMA-K Δ 1310□□	8.41	41.59	51.17
	1.5	ECMA-K Δ 1315□□	11.18	55.29	57.41
	2.0	ECMA-K Δ 1320□□	14.59	72.15	34.94
	2.0	ECMA-K Δ 1820□□	34.68	171.49	34.94

Servo Drive (kW)	Motor	Rotor Inertia J ($\times 10^{-4}$ kg.m ²)	Regenerative power from empty load 3000 r/min to stop Eo (joule)	The maximum regenerative power of capacitance Ec (joule)	
Medium-High Inertia	0.75	ECMA-L Δ 1305□□	13.1	16.20	42.43
	1.5	ECMA-L Δ 1313□□	23.6	29.18	42.43
	3.0	ECMA-L Δ 1830□□	54.95	67.93	42.43
	3.0	ECMA-J Δ 1330□□	12.7	15.70	42.43
	4.5	ECMA-L Δ 1845□□	77.75	96.12	51.17
	5.5	ECMA-L Δ 1855□□	99.78	123.35	57.41
	7.5	ECMA-L Δ 1875□□	142.7	176.41	62.40
High Inertia	1.0	ECMA-L Δ 1308□□	17.1	84.56	42.43
	1.5	ECMA-M Δ 1309□□	11.18	55.29	57.41

$E_o = J * \omega^2 / 182$ (joule), ω : r/min

Assume that the load inertia is N times to the motor inertia and the motor decelerates from 3000 r/min to 0, its regenerative energy is $(N+1) \times E_o$. The consumed regenerative resistor is $(N+1) \times E_o - E_c$ joule. If the cycle of back and forth operation is T sec, then the power of regenerative resistor it needs is $2 \times ((N+1) \times E_o - E_c) / T$.

Followings are the calculation procedure:

Step	Item	Calculation and Setting Method
1	Set the capacity of regenerative resistor to the maximum	Set P1-53 to the maximum value
2	Set T cycle of back and forth operation	Enter by the user
3	Set the rotational speed ω	Enter by the user or read via P0-02
4	Set the load/motor inertia ratio N	Enter by the user or read via P0-02
5	Calculate the maximum regenerative energy Eo	$E_o = J * \omega^2 / 182$
6	Set the absorbable regenerative energy Ec	Refer to the above table
7	Calculate the needful capacitance of regenerative resistor	$2 \times ((N+1) \times E_o - E_c) / T$

Take 400 W as the example. The cycle of back and forth operation is $T = 0.4$ sec, the maximum speed is 3000 r/min, and the load inertia is 7 times to the motor inertia. Then, the needful power of regenerative resistor is $2 \times ((7+1) \times 1.37 - 8) / 0.4 = 14.8$ W. If it is smaller than the built-in capacity of regenerative resistor, the built-in 60 W regenerative resistor will do. Generally speaking, when the need of the external load inertia is not much, the built-in regenerative is enough. The smaller power of the regenerative resistor it is, the more energy it accumulates and the higher temperature it will be. When the temperature is higher than a specific value, AL005 occurs.

(b) If the external load torque exists, the motor is in reverse rotation.

Usually, the motor is in forward rotation, which means the torque output direction of the motor is the same as the rotation direction. However, in some applications, the direction of torque output is different from the rotation. In this situation, the motor is in reverse rotation. The external energy goes into the servo drive through the motor. The diagram below is one example. When the external force direction is the same as the moving direction, the servo system has to use the force of the opposite direction to keep the speed and stability. Huge amount of energy will return to the servo drive at the moment. When DC-BUS is full and unable to store the regenerative energy, the energy will be led to the regenerative resistor and consumed.

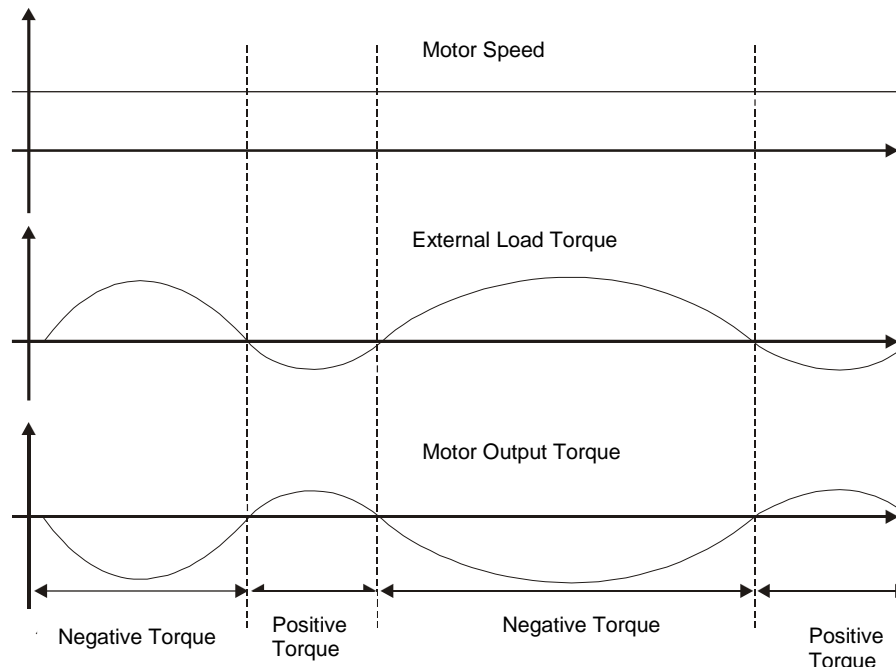

Negative torque: $T_L \times W_r$ T_L : external load torque

For safety reasons, please calculate it by considering the safest situation.

For example, when the external load torque is the +70% rated torque and the rotation reaches 3000 r/min, then take 400 W (the rated torque is 1.27 Nt-m) as the example. The user has to connect the regenerative resistor of 40Ω , which is

$$2 \times (0.7 \times 1.27) \times (3000 \times 2 \times \pi / 60) = 560 \text{ W.}$$

(2) Simple Selection

Choose the appropriate regenerative resistor according to the allowable frequency and empty load frequency in actual operation. The so-called empty allowable frequency is the frequency of continuous operation when the servo motor runs from 0 r/min to the rated speed and then decelerates from the rated speed to 0 r/min within the shortest time. The following table lists the allowable frequency when the servo drive runs without load (times/min).

Allowable frequency when the servo motor runs without load (times/min) and uses a built-in regenerative resistor														
Servo Motor	Motor Capacity	600 W	750 W	900 W	1.0 kW	1.5 kW	2.0 kW	2.0 kW	3.0 kW	4.5 kW	5.5 kW	7.5 kW	11.0 kW	15.0 kW
		06	07	09	10	15	20	20	30	45	55	75	1B	1F
ECMA□□C		-	312	-	137	-	83 (F100)	-	-	-	-	-	-	-
ECMA□□E		-	-	-	42	32	24 (F130)	10 (F180)	11	-	-	-	-	-
ECMA□□F		-	-	-	-	-	-	-	11	8	-	-	-	-
ECMA□□G		42	-	31	-	-	-	-	-	-	-	-	-	-
ECMA□□J		-	537	-	-	-	-	-	-	-	-	-	-	-
ECMA□□K		-	-	-	162	122	-	-	-	-	-	-	-	-
ECMA□□L		-	-	-	-	-	-	-	-	-	-	-	-	-

When the servo motor runs with load, the allowable frequency will be different according to different load inertia or speed. The following is the calculation method.

m represents load / motor inertia ratio.

$$\text{Allowable frequency} = \frac{\text{Allowable frequency when servo motor run without load}}{m + 1} \times \left(\frac{\text{Rated speed}}{\text{Operating speed}} \right)^2 \frac{\text{times}}{\text{min.}}$$

The comparison table of external regenerative resistor is provided below. Please choose the appropriate regenerative resistor according to the allowable frequency.

The table below describes the suggested allowable frequency (times/min) of regenerative resistor when the servo drive runs without load.

Allowable frequency of regenerative resistor when the servo drive runs without load (times/min)								
Recommended regenerative resistor	Motor Capacity	ECMA□□C						
		100 W	200 W	400 W (F60)	400 W (F80)	750 W	1.0 kW	2.0 kW
		01	02	04	04	07	10	20
BR400W040 (400 W 40Ω)		-	-	8608	3506	2110	925	562
BR1K0W020 (1 kW 20Ω)		-	-	-	8765	5274	2312	1406

Recommended regenerative resistor	Motor Capacity	ECMA□□E					
		0.5 kW	1 kW	1.5 kW	2.0 kW (F130)	2.0 kW (F180)	3.0 kW
		05	1.0	15	20	20	30
BR400W040 (400 W 40Ω)		291	283	213	163	68	-
BR1K0W020 (1 kW 20Ω)		729	708	533	408	171	-
BR1K5W005*2 pcs (3 kW 10Ω)		-	-	-	-	-	331

Recommended regenerative resistor	Motor Capacity	ECMA□□F					
		3.0 kW	4.5 kW	5.5 kW	7.5 kW	11.0 kW	15.0 kW
		30	45	55	75	1B	1F
BR1K5W005*2 pcs (3 kW 10Ω)		331	234	182	127	124	74

Allowable frequency of regenerative resistor when the servo drive runs without load (times/min)				
Recommended regenerative resistor	Motor Capacity	ECMA□□G		
		0.3 kW	0.6 kW	0.9 kW
		03	06	09
BR400W040 (400 W 40Ω)		292	283	213
BR1K0W020 (1 kW 20Ω)		729	708	533

Recommended regenerative resistor	Motor Capacity	ECMA□□K		
		1.0 kW	1.5 kW	2.0 kW
		10	15	20
BR400W040 (400 W 40Ω)		-	488	665

Recommended regenerative resistor	Motor Capacity	ECMA□□L			
		3.0 kW	4.5 kW	5.5 kW	7.5 kW
		30	45	55	75
BR400W040 (400 W 40Ω)		177	-	-	-
BR1K0W020 (1 kW 20Ω)		-	312	243	170

If the regenerative resistor wattage is not enough, you can connect the same regenerative resistors in parallel to increase the power, but the resistance cannot be lower than the minimum allowable resistance specified in the manual after parallel connection.

Dimensions of Regenerative Resistor

Delta Part Number: BR400W040 (400 W 40Ω)

L1	L2	H	D	W
265	250	30	5.3	60

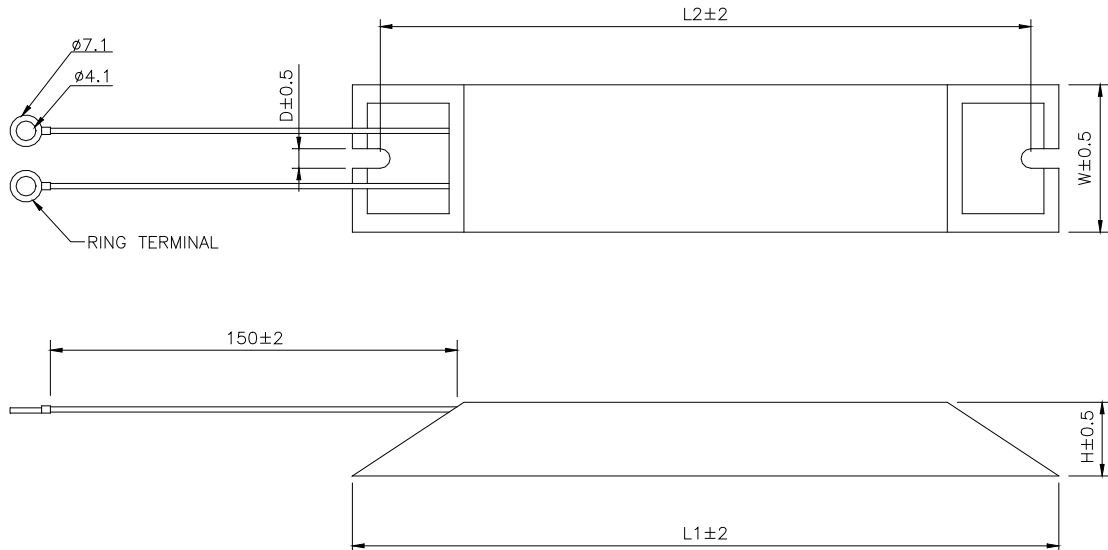

Delta Part Number: BR1K0W020 (1 kW 20Ω), BR1K5W005 (1.5 kW 5Ω)

A	B	C	D	E	F	G	ØH	ØI
470	445	48	9.1	98	47	15	55	8.1

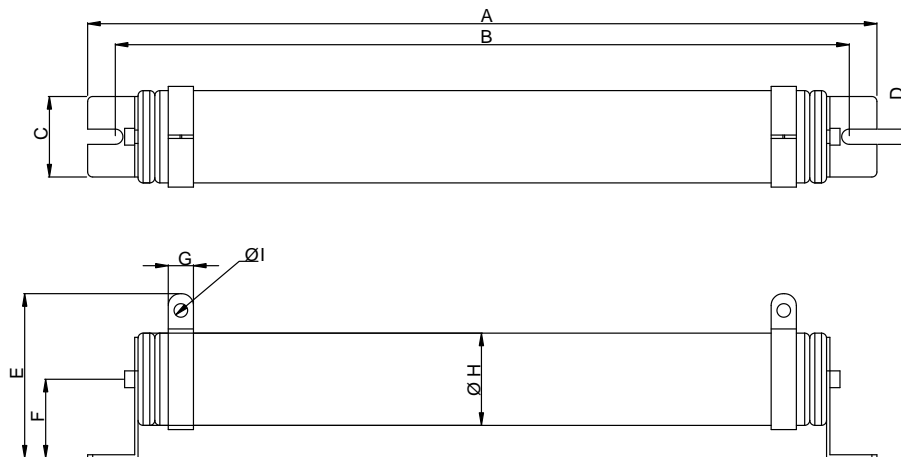

2.9 The Use of Servo Motor

Please pay attention to the following when using servo motors with brake:

- Never apply the brake to dynamic braking.

2.9.1 Troubleshooting for the Motor Operation and Status

Servo motor makes abnormal noises:

Possible causes	Confirmation	Solutions
There is a source of vibration in the connecting component.	Check if there is any foreign object, damage, or deformation in the movable parts of the connecting component.	Replace the connecting component (such as coupling) or contact the manufacturer.
The encoder is subject to excessive vibration / shocks.	<ol style="list-style-type: none"> 1. Whether the servo motor has been subjected to excessive force or vibration, resulting in damage to the encoder. 2. Remove and shake the motor to see if there is any abnormal noises (disk damage). 3. Visually inspect the encoder's rear cover for dust (encoder damage). 	Replace the servo motor.

Servo motor overheating:

Possible causes	Confirmation	Solutions
Poor thermal conductivity of the servo motor mounting surface.	Measure the temperatures of the servo motor frame and the mounting surface (metal). The temperature difference should not exceed 20°C (68°F).	Make sure the installation surface is flat. If there are other objects (such as paint, gasket) between the mounting surface and motor surface resulting in poor heat dissipation, remove the objects or apply other methods to help dissipate heat (such as forced air cooling for the servo motor).

2.9.2 Mounting Directions and Precautions for the Servo Motor

You can install the servo motor horizontally or vertically.

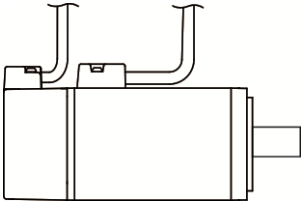
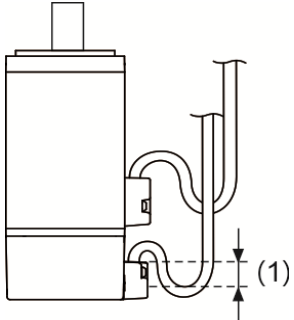
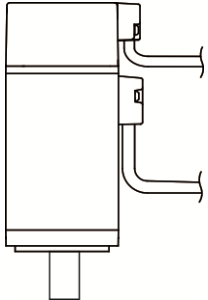
Orientation	Precautions
<p data-bbox="316 365 435 394">Horizontal</p> 	<p data-bbox="596 439 1286 524">If you are using a servo motor with oil seal, please refer to the precaution measures in section 2.9.5 for preventing oil / water from entering the servo motor.</p>
<p data-bbox="217 618 536 647">Vertical (with shaft end up)</p> 	<ul style="list-style-type: none"> <li data-bbox="596 674 1246 730">■ Do not use servo motors with oil seal in the vertical orientation. <li data-bbox="596 734 1286 790">■ When wiring, you need to install an oil trap (marked as (1) in the left) to prevent vapor from entering the motor. <li data-bbox="596 795 1286 913">■ When installing the servo motor in a machine (such as a gearbox), you must comply with the precaution measures in section 2.9.5 to prevent oil and gas from entering the servo motor.
<p data-bbox="201 992 552 1021">Vertical (with shaft end down)</p> 	<p data-bbox="596 1115 1286 1200">If you are using a servo motor with oil seal, please refer to the precaution measures in section 2.9.5 for preventing oil / water from entering the servo motor.</p>

Note: if you need to install gears on the servo motor, please follow the manufacturer's instructions for installation.

2.9.3 Precautions for Using Servo Motors with Oil Seal

This section defines the operating conditions for using motors with oil seal:

1. In the operating environment, the oil level must be lower than the oil seal lip.

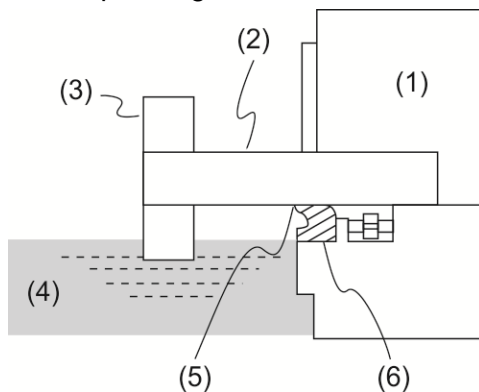

(1) Servo motor; (2) Motor shaft; (3) Gear; (4) Oil; (5) Oil seal lip; (6) Oil seal

2. The oil seal cannot be submerged in the liquid; it can only withstand splashes of oil.
3. The oil seal lip cannot be soaked in oil.
4. The oil seal cannot be lower than the oil level; otherwise the oil will enter the servo motor and cause damage.

2.9.4 Precautions for Using Couplings

Caution:

It is suggested to use a flexible coupling specifically designed for servo motors, especially double spring couplings, which provide some buffer tolerance during eccentric motion and deflection. Please select appropriate coupling size for the operating conditions. Improper usage or connection may result in damage.

1. Wipe off the anti-rust coating or oil on the motor shaft end.
2. If using a servo motor with a keyway, attach the supplied key or a key that matches the dimensions of the drawing to the motor shaft.

Note: when installing the keyway on the motor, do not apply excessive force to the keyway or motor shaft.

3. Use dial gauge or other methods to ensure that the centering accuracy is within the specification.

If you cannot use the dial gauge or other methods, you can slide the coupling along both axes and adjust it until it does not get stuck.

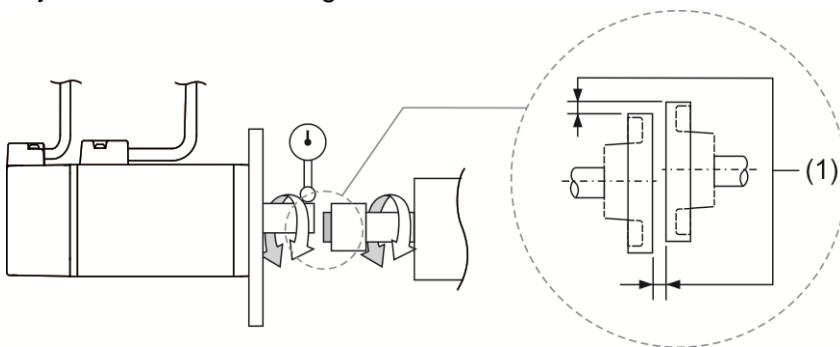

- (1) The distance is measured at four different positions on the circumference for the centering accuracy. The difference between the maximum and minimum measurement values must be 0.03 mm or less; and even within this range, you can make adjustments to increase the centering accuracy as much as possible.

Note: when measuring, rotate the coupling and the motor shaft together.

4. Installation safety precautions for the servo motor shaft

- (1) When connecting the shaft, ensure that the required centering accuracy is reached. If the shaft is not correctly centered, vibration may damage the bearings and encoder.
- (2) When installing the coupling, do not apply excessive force to the shaft. Also, do not apply excessive force to the area around the encoder, as the impact may damage the encoder.

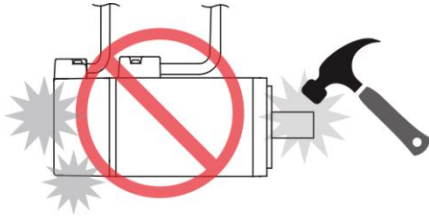

- (3) If the coupling makes any abnormal noises, re-align the shaft until the noises disappear.
- (4) Ensure that the axial load and radial load are within the specifications. Please refer to the specifications for the maximum axial load (N) and maximum radial load (N) for each servo motor.

2.9.5 Oil and Water Prevention Measures for the Servo Motor

Please follow the following precautions and do not allow water, oil, or other foreign objects to enter the servo motor:

1. Do not submerge the cable in oil or water.

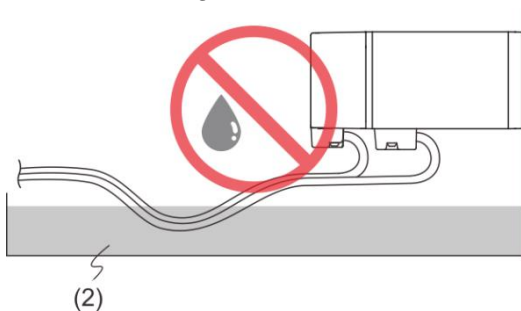

2. If oil or water is unavoidable, please use oil-resistant cables. Delta does not provide oil-resistant cable.
3. If the servo motor must be mounted with the shaft end up, do not use it in a machine, gearbox, or other environments where the servo motor may have contact with oil or water.

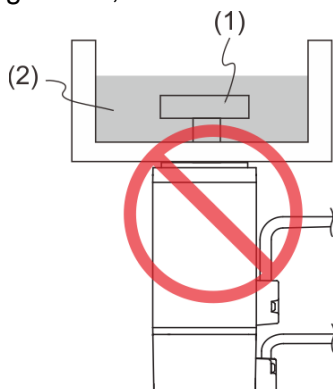

(1) Gear; (2) Oil

4. Do not use the servo motor in an environment with cutting fluid. Depending on the type of cutting fluid, the sealing material, the coated colloids, cables, or other components may be affected or even deteriorate.
5. Do not let the servo motor be in continuous exposure to oil mist, water vapor, oil, water, or grease.

If you cannot avoid using the servo motor under the above conditions, please take prevention measures to avoid dirt and water for the machine.

2.9.6 Measures to Suppress Temperature Increase of the Servo Motor

1. When installing the servo motor, please pay attention to the cooling conditions (such as size of the heat sink) provided in the specifications of each servo motor type.
2. The servo motor generates heat during operation, and the heat generated by the servo motor is dissipated to the heat sink through the motor mounting surface. Therefore, if the surface area of the heat sink is too small, the temperature of the servo motor may increase abnormally.
3. If it is difficult to apply large heat sinks in the operating environment or if the ambient air temperature exceeds the given specifications, please take the following measures:
 - (1) Reduce servo motor full load rating: for more details, please refer to the specifications of each servo motor type. When selecting servo motors, consider motors with the power capacity 1 to 2 levels higher.
 - (2) Reduce the acceleration and deceleration of the work cycle to lower the motor load.
 - (3) Apply external forced air cooling to the servo motor using cooling fans or other means.

Important: avoid placing a gasket or other insulating materials between the servo motor and heat sink, as this may result in motor temperature increase, inferior noise resistance, and motor malfunction.

Chapter 3 Wiring

This chapter provides information on wiring ASDA-A2 series products, the descriptions of I/O signals and gives typical examples of wiring diagrams.

3.1 Connections - 220V series

3.1.1 Connecting to Peripheral Devices

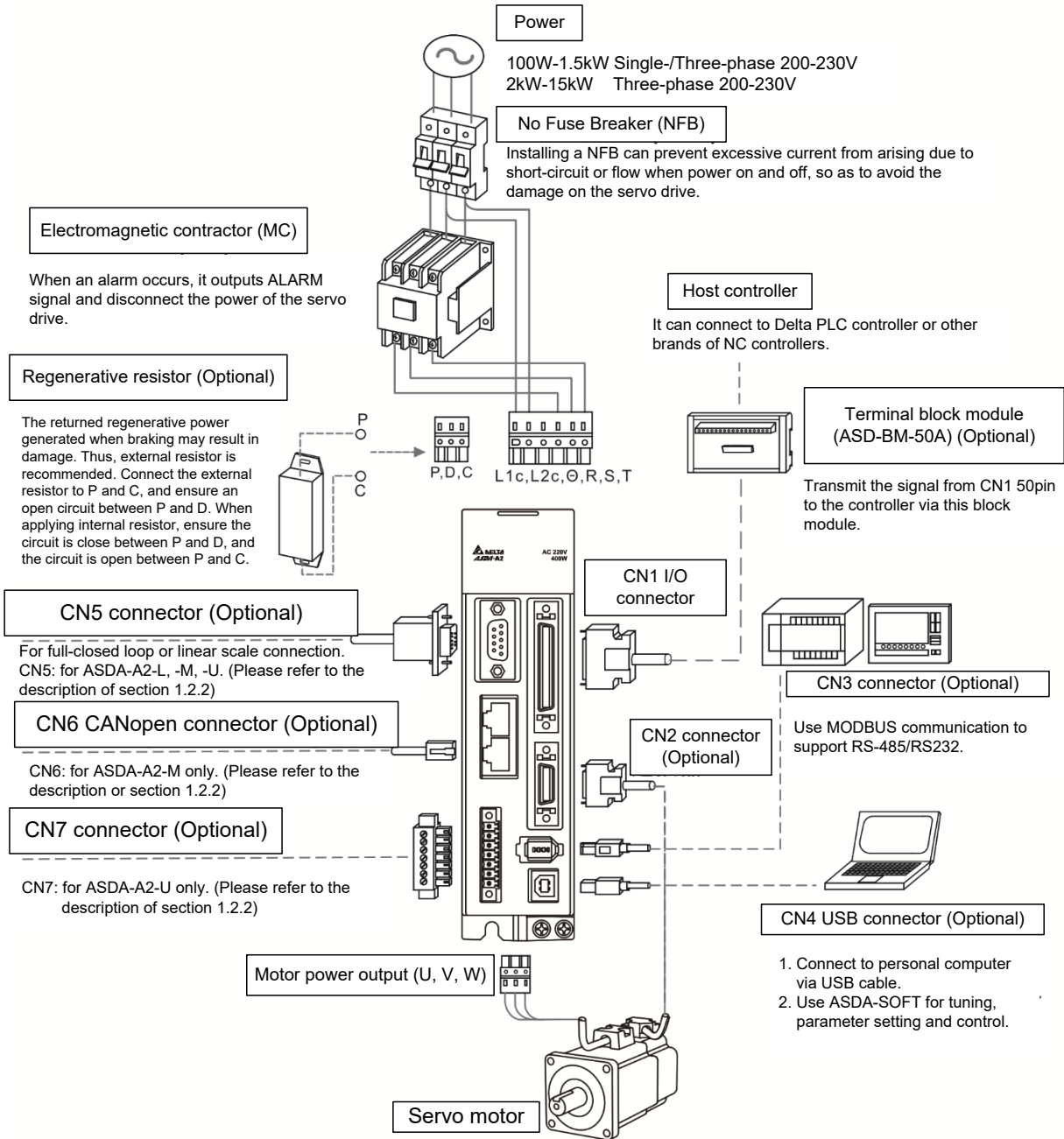

Installation notes:

1. Check if the power and wiring among R, S, T and L_{1C}, L_{2C} are correct.
Please refer to Chapter 11 for Specifications. Make sure the input voltage is correct, or it might damage the servo drive or danger may occur.
2. Please check if the output terminal U, V, W of the servo motor is correctly wired. The incorrect wiring may disable the operation of the motor or cause malfunction.
3. When applying to the external regenerative resistor, the contact between P[⊕] and D should be opened and the external regenerative resistor should connect to terminal P[⊕] and C. When applying to the internal regenerative resistor, the contact between P[⊕] and D should be closed and the contact between P[⊕] and C should be opened.
4. When an alarm occurs or the system is in emergency stop status, use ALARM or WARN to output and disconnect the power of magnetic contactor in order to disconnect the power of servo drive.

3.1.2 Connectors and Terminals of Servo Drive

Terminal Signal	Name	Description													
L _{1C} , L _{2C}	Power input of the control circuit	Connect to single-phase AC power (select the appropriate voltage specification according to the product).													
R, S, T	Power input of the main circuit	Connect to three-phase AC power (select the appropriate voltage specification according to the product).													
U, V, W FG	Motor cable	Connect to the servo motor.													
		<table border="1"> <thead> <tr> <th>Terminal Symbol</th> <th>Wire Color</th> <th>Description</th> </tr> </thead> <tbody> <tr> <td>U</td> <td>Red</td> <td rowspan="3">Three-phase main power cable of the motor.</td> </tr> <tr> <td>V</td> <td>White</td> </tr> <tr> <td>W</td> <td>Black</td> </tr> <tr> <td>FG</td> <td>Green</td> <td>Connect to ground terminal (\oplus) of the servo drive.</td> </tr> </tbody> </table>	Terminal Symbol	Wire Color	Description	U	Red	Three-phase main power cable of the motor.	V	White	W	Black	FG	Green	Connect to ground terminal (\oplus) of the servo drive.
		Terminal Symbol	Wire Color	Description											
		U	Red	Three-phase main power cable of the motor.											
		V	White												
W	Black														
FG	Green	Connect to ground terminal (\oplus) of the servo drive.													
P ⁺ , D, C, \ominus	Regenerative resistor terminal or braking unit	Internal resistor The contact between P ⁺ and D end should be closed; contact between P ⁺ and C end should be opened.													
		External resistor Connect P ⁺ , C ends to the resistor and the contact between P ⁺ and D end should be opened.													
		External braking unit P ⁺ and P ⁻ of the brake unit should connect to P ⁺ and \ominus respectively. The contact between P ⁺ and D and P ⁺ and C should be opened.													
\oplus	Ground terminal	Connect to the ground wire of power and servo motor.													
CN1	I/O connector (Optional)	Connect to the host controller. Please refer to section 3.4.													
CN2	Connector (Optional)	Connect encoder of the motor. Please refer to section 3.5.													
CN3	Connector (Optional)	Connect to RS-485 or RS-232. Please refer to section 3.6.													
CN4	USB connector (Type B) (Optional)	Connect to personal computer (PC or notebook). Please refer to section 3.7.													
CN5	Connector (Optional)	Connect to linear scale or encoder for full-closed loop and motor feedback. Please refer to section 3.8.													
CN6	CANopen connector (Optional)	RJ45 connector. Please refer to section 3.9.													

Terminal Signal	Name	Description
CN7	Extension digital input connector (Optional)	Extension DI connector. Please refer to section 3.10.
CN8	Reserved connector	Reserved.

Pay special attention to the followings when wiring:

1. When the power is cutoff, do not touch R, S, T and U, V, W since the capacitance inside the servo drive still contains huge amount of electric charge. Wait until the charging light is off.
2. Separate R, S, T and U, V, W from the other wires. The interval should be at least 30 cm (11.8 inches).
3. If the wire of encoder CN2 or CN5 connector is not long enough, please use shielded twisted-pair cable which cannot exceed 20 meters (65.62 feet). If it exceeds 20 meters, please choose the bigger wire diameter of signal cable to ensure it will not cause signal fading. As for the encoder wiring specification of 20-meter-long cable, please use AWG26 of wire size and metal braided shield twisted-pair cable which complies with the standard of UL 2464.
4. When using CANopen, please use the standard shielded twisted-pair cables to ensure the communication quality.
5. When selecting the wire rod, please refer to Section 3.1.6.
6. Do not install the plug-in capacitance in servo drive. It might burn out the soft-start resistance and cause danger.

3.1.3 Wiring Method

The wiring method of 220V servo drive is divided into single-phase and three-phase. In the diagram below, Power On is contact **a**, and Power Off and ALRM_RY are contact **b**. MC is the coil of magnetic contactor, self-remaining power, and the contact of main power circuit.

- Wiring Method of Single-phase Power Supply (suitable for 1.5 kW and models below 1.5 kW)

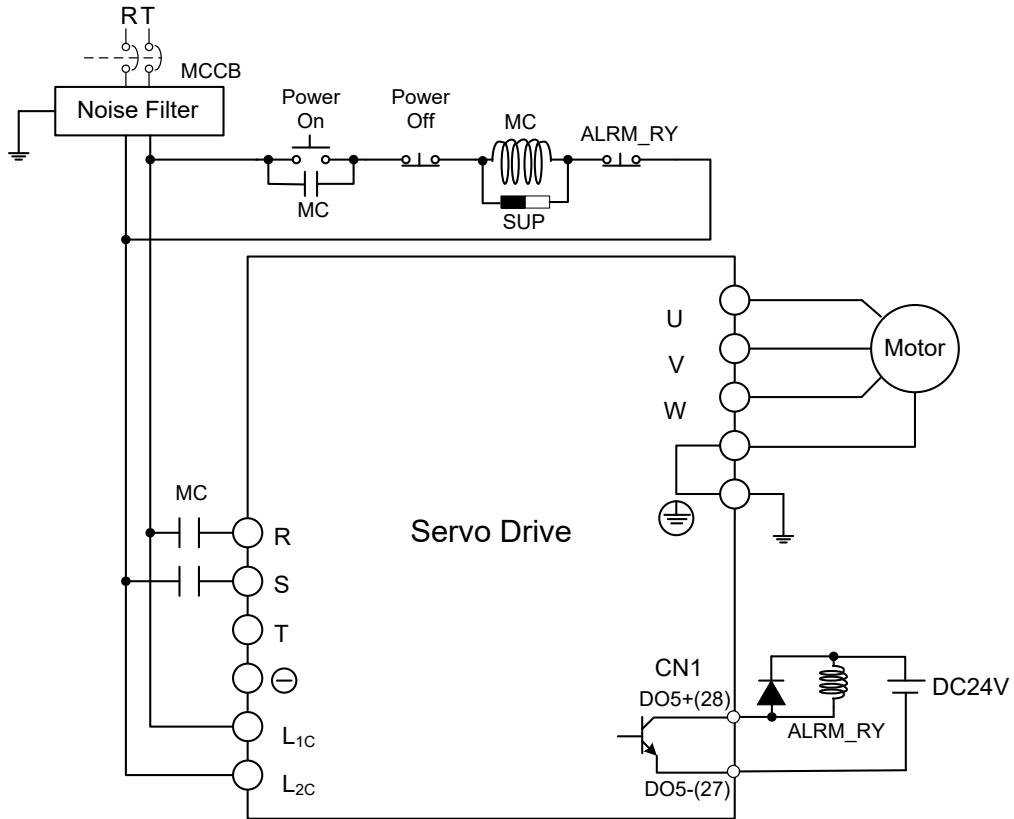

■ Wiring Method of Three-phase Power Supply (suitable for all series)

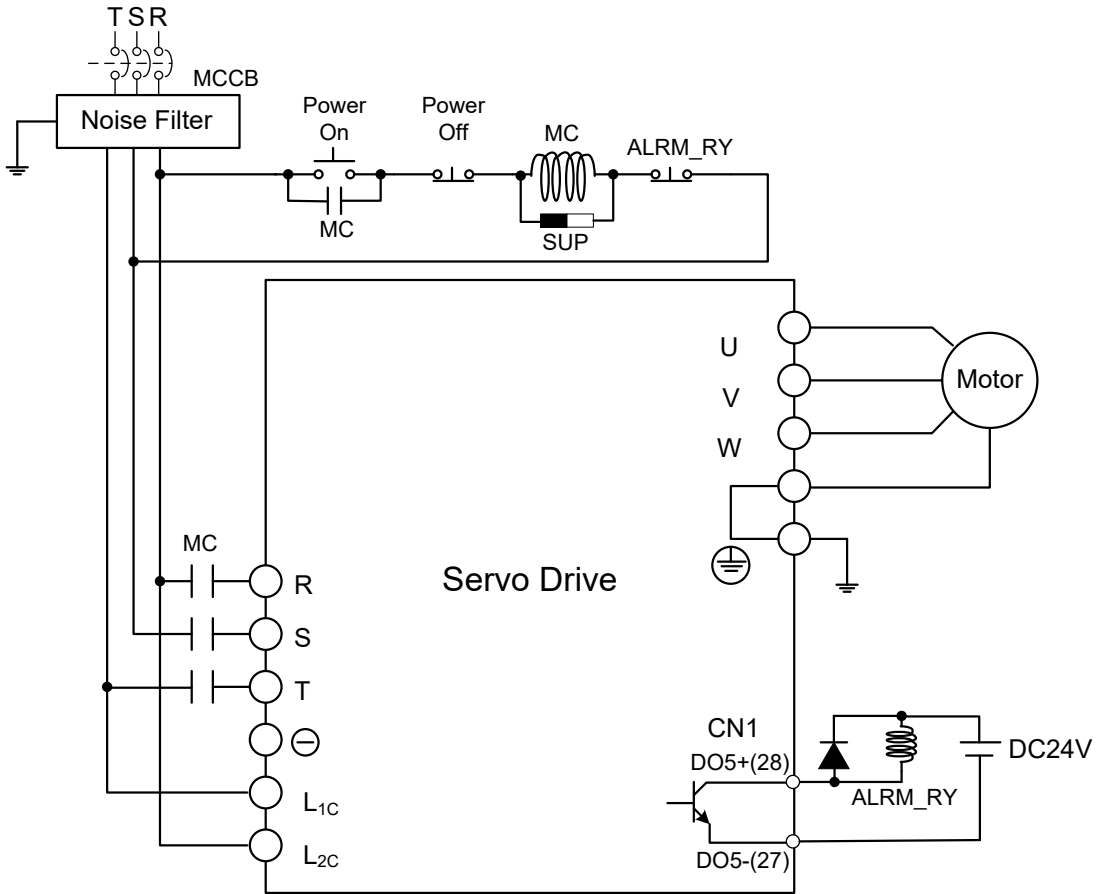

3.1.4 Specification of Motor Power Cable

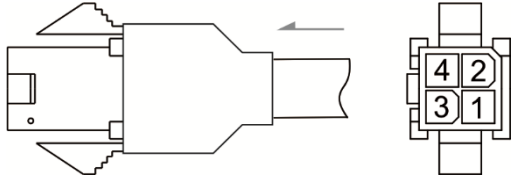
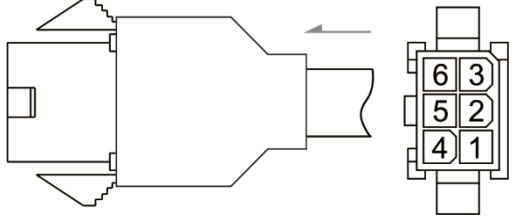
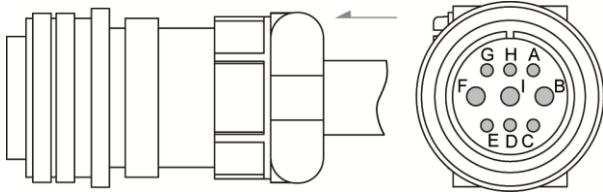
Motor Model	U, V, W / Connector of Brake	Terminal Definition
ECMA-C1040F□S (50 W) ECMA-CΔ0401□S (100 W) ECMA-CΔ0602□S (200 W) ECMA-CΔ0604□S (400 W) ECMA-CΔ0604□H (400 W) ECMA-CΔ0804□7 (400 W) ECMA-CΔ0807□S (750 W) ECMA-CΔ0807□H (750 W) ECMA-CΔ0907□S (750 W) ECMA-CΔ0910□S (1000 W)		A
ECMA-C1040F□S (50 W) ECMA-CΔ0401□S (100 W) ECMA-CΔ0602□S (200 W) ECMA-CΔ0604□S (400 W) ECMA-CΔ0804□7 (400 W) ECMA-CΔ0807□S (750 W) ECMA-CΔ0807□H (750 W) ECMA-CΔ0907□S (750 W) ECMA-CΔ0910□S (1000 W)		B
ECMA-GΔ1303□S (300 W) ECMA-EΔ1305□S (500 W) ECMA-FΔ1305□S (500 W) ECMA-GΔ1306□S (600 W) ECMA-FΔ1308□S (850 W) ECMA-GΔ1309□S (900 W) ECMA-CΔ1010□S (1000 W) ECMA-EΔ1310□S (1000 W) ECMA-FΔ1313□S (1300 W) ECMA-EΔ1315□S (1500 W) ECMA-FΔ1318□S (1800 W) ECMA-CΔ1020□S (2000 W) ECMA-EΔ1320□S (2000 W) ECMA-CΔ1330□4 (3000 W)		C MIL 20-18S

Motor Model	U, V, W / Connector of Brake	Terminal Definition
ECMA-E Δ 1820 \square S (2000 W) ECMA-C Δ 1330R8LA (3000 W) ECMA-E Δ 1830 \square S (3000 W) ECMA-F Δ 1830 \square S (3000 W) ECMA-E Δ 1835 \square S (3500 W) ECMA-C Δ 1340RPLA (4000 W) ECMA-F Δ 1845 \square S (4500 W) ECMA-C Δ 1350R8LA (5000 W)		D MIL 24-11S
ECMA-F Δ 1855 \square 3 (5500 W) ECMA-F Δ 1875 \square 3 (7500 W) ECMA-F1221B \square 3 (11 kW) ECMA-F1221F \square S (15 kW)		E MIL 32-17S

Motor Model	Connector of Brake	Terminal Definition
ECMA-F21855 \square 3 (5500 W) ECMA-F21875 \square 3 (7500 W)		F

Wiring Name	U (Red)	V (White)	W (Black)	CASE GROUND (Yellow/Green)	BRAKE1 (Note*5)	BRAKE2 (Note*5)
A	1	2	3	4	-	-
B	1	2	4	5	3	6
C	F	I	B	E	G	H
D	D	E	F	G	A	B
E	A	B	C	D	-	-

Wiring Name	BRAKE1 (Red)	BRAKE2 (Black)
F	A	B

When selecting the wire rod, please choose a 600V PVC cable and the length should not be longer than 30 m (98.43 feet). If the length exceeds 30 m, refer to the voltage drop when selecting the wire size. Please refer to Section 3.1.6 for wire rod selection.

Note:

1. No polarity for brake coil. The wiring name is BRAKE1 & BRAKE2.
2. Power for brake is DC24V. Never share it with the power of control signal VDD.
3. Box, (Δ) in servo motor model represents encoder type. Δ = 1: incremental, 20-bit; Δ = 2: incremental, 17-bit; Δ = 3: 2500 ppr; Δ = A: absolute.
4. Box, (\square) in servo motor model represents brake or keyway / oil seal.
5. Color of brake cable F40 to F86: brown and blue; color of brake cable for F100 or above: yellow and blue.

3.1.5 Specification of Encoder Cable Connector

Encoder Connection (Diagram 1)

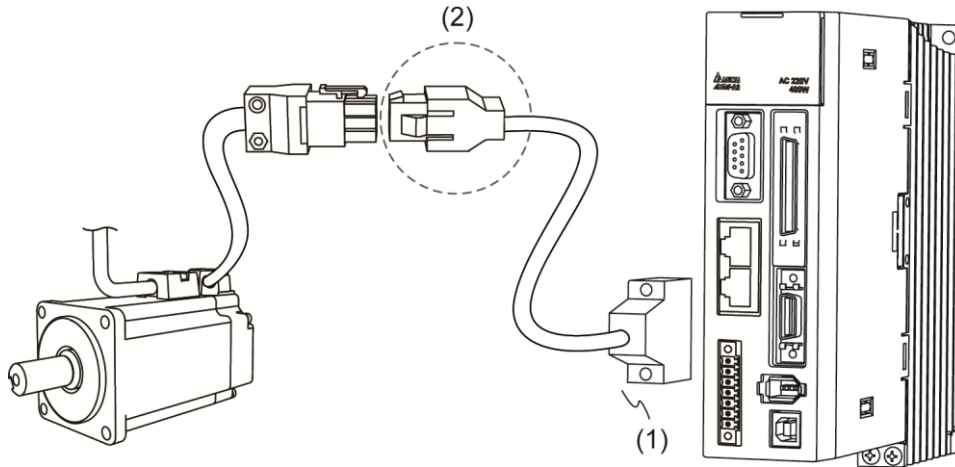

(1) CN2 connector; (2) Quick connector (connector of encoder cable)

Note: this diagram shows the connection between the servo drive and the motor encoder. It is not drawn by the practical scale and specification will be different according to the selected servo drive and motor model.

1. Please refer to the Section of Specification and Definition of Encoder Connector.
2. Please refer to Section 3.5 CN2 Connector.

Motor Model	Connector of Encoder Cable
ECMA-C1040F□ (50 W) ECMA-CΔ0401□S (100 W) ECMA-CΔ0602□S (200 W) ECMA-CΔ0604□S (400 W) ECMA-CΔ0604□H (400 W) ECMA-CΔ0804□7 (400 W) ECMA-CΔ0807□S (750 W) ECMA-CΔ0807□H (750 W) ECMA-CΔ0907□S (750 W) ECMA-CΔ0910□S (1000 W)	

Specification and Definition of Incremental Encoder Connector:

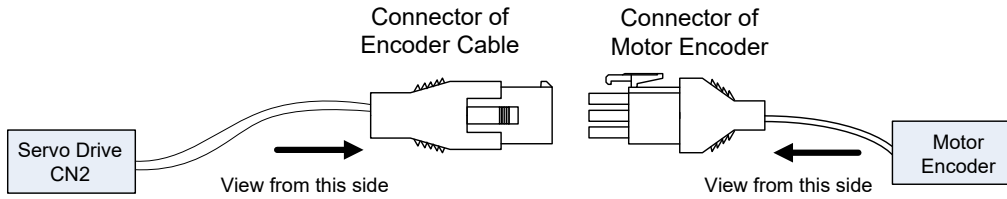

1 White T+	2 Reserved	3 Reserved
4 White/Red T-	5 Reserved	6 Reserved
7 Brown DC+5V	8 Blue GND	9 Shield

(Encoder type is 17bit, 20bit):

3 Reserved	2 -	1 White T+
6 Reserved	5 -	4 White/Red T-
9 Shield	8 Blue GND	7 Brown DC+5V

(The wire color of the servo drive is for reference only. Please refer to the real object.)

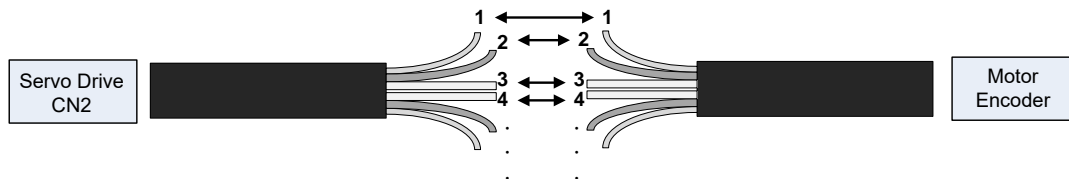

If not using housing and directly wiring the cores, please follow the corresponding core number for wiring. For example, core number 1 from the servo drive CN2 should connect to core number 1 from the motor encoder; core number 2 from the servo drive CN2 should connect to core number 2 from the motor encoder and so on. Please number the cores from the servo drive in order and then connect it to the encoder.

Specification and Definition of Absolute Encoder Connector:

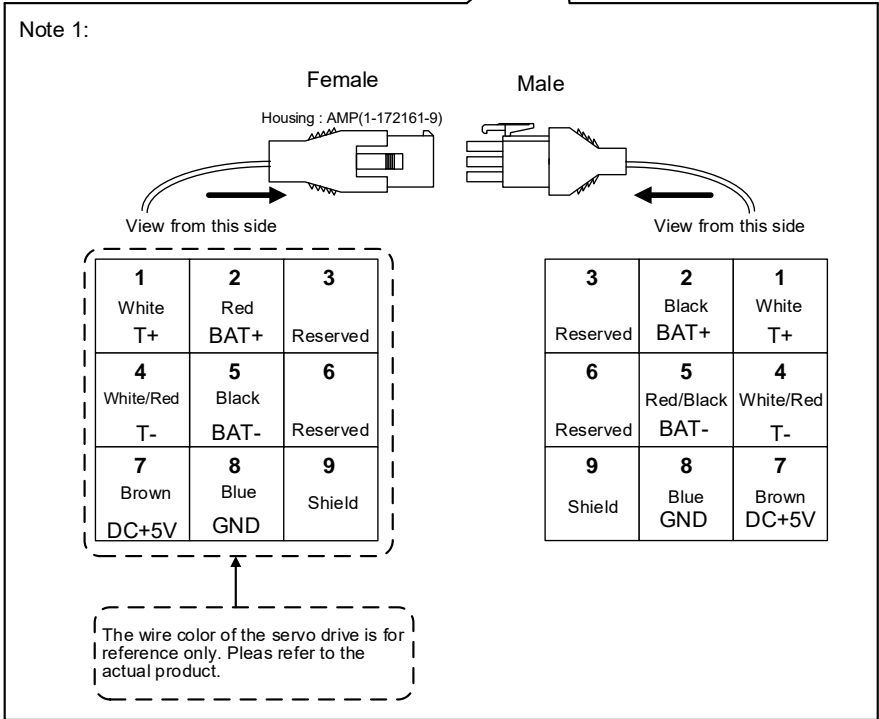
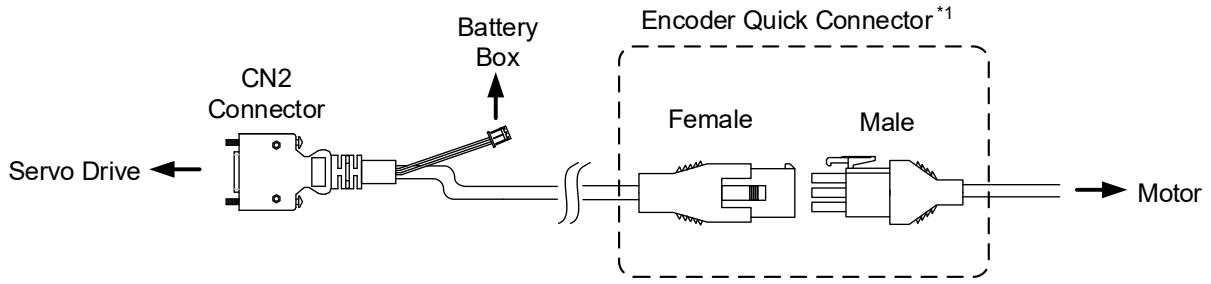

Encoder Connection (Diagram 2):

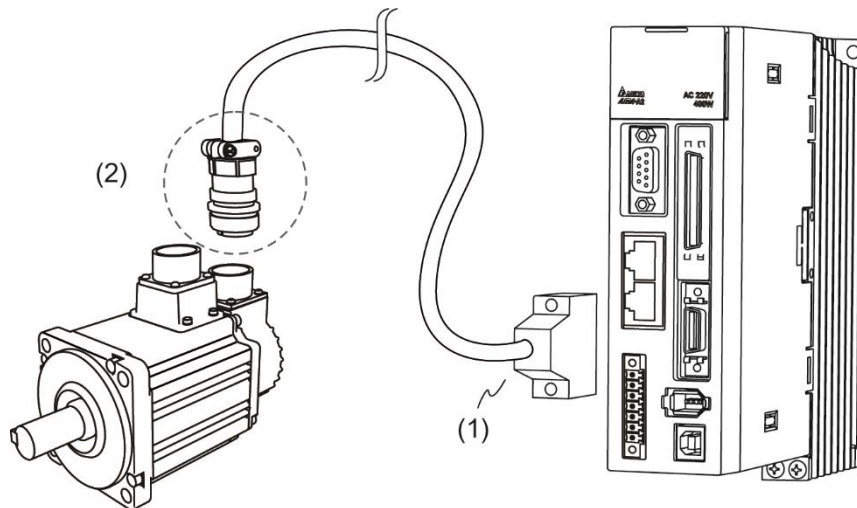

(1) CN2 connector; (2) Military connector (connector of encoder cable)

Note: This diagram shows the connection between the servo drive and the motor encoder. It is not drawn by the actual scale and specification will be different according to the selected servo drive and motor model.

Please refer to Section 3.5, CN2 Connector.

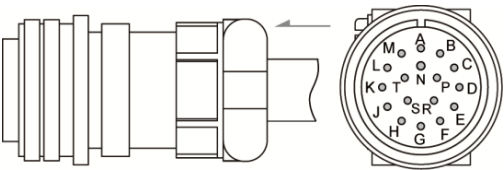
Motor Model	Connector of Encoder Cable																			
ECMA-G Δ 1303 \square S (300 W) ECMA-E Δ 1305 \square S (500 W) ECMA-F Δ 1305 \square S (500 W) ECMA-G Δ 1306 \square S (600 W) ECMA-F Δ 1308 \square S (850 W) ECMA-G Δ 1309 \square S (900 W) ECMA-C Δ 1010 \square S (1000 W) ECMA-E Δ 1310 \square S (1000 W) ECMA-F Δ 1313 \square S (1300 W) ECMA-E Δ 1315 \square S (1500 W) ECMA-F Δ 1318 \square S (1800 W) ECMA-C Δ 1020 \square S (2000 W) ECMA-E Δ 1320 \square S (2000 W) ECMA-E Δ 1820 \square S (2000 W) ECMA-C Δ 1330 \square 4 (3000 W) ECMA-C Δ 1330R8LA (3000 W) ECMA-E Δ 1830 \square S (3000 W) ECMA-C Δ 1340RPLA (4000 W) ECMA-C Δ 1350R8LA (5000 W) ECMA-F Δ 1830 \square S (3000 W) ECMA-E Δ 1835 \square S (3500 W) ECMA-F Δ 1845 \square S (4500 W) ECMA-F Δ 1855 \square 3 (5500 W) ECMA-F Δ 1875 \square 3 (7500 W) ECMA-F1221B \square 3 (11 kW) ECMA-F1221F \square S (15 kW)		<table border="1"> <thead> <tr> <th>Pin No.</th> <th>Terminal Identification</th> <th>Color</th> </tr> </thead> <tbody> <tr> <td>A</td> <td>T+</td> <td>White</td> </tr> <tr> <td>B</td> <td>T-</td> <td>White/Red</td> </tr> <tr> <td>S</td> <td>DC+5V</td> <td>Brown</td> </tr> <tr> <td>R</td> <td>GND</td> <td>Blue</td> </tr> <tr> <td>L</td> <td>BRAID SHIELD</td> <td>-</td> </tr> </tbody> </table>	Pin No.	Terminal Identification	Color	A	T+	White	B	T-	White/Red	S	DC+5V	Brown	R	GND	Blue	L	BRAID SHIELD	-
Pin No.	Terminal Identification	Color																		
A	T+	White																		
B	T-	White/Red																		
S	DC+5V	Brown																		
R	GND	Blue																		
L	BRAID SHIELD	-																		

Please select shielded multi-core and the shielded cable should connect to the SHIELD end.
 Please refer to the description of Section 3.1.6.

Note:

- Box, (Δ) in servo motor model represents encoder type. Δ = 1: incremental, 20-bit; Δ = 2: incremental, 17-bit; Δ = A: absolute.
- Box, (\square) in servo motor model represents brake or keyway / oil seal.

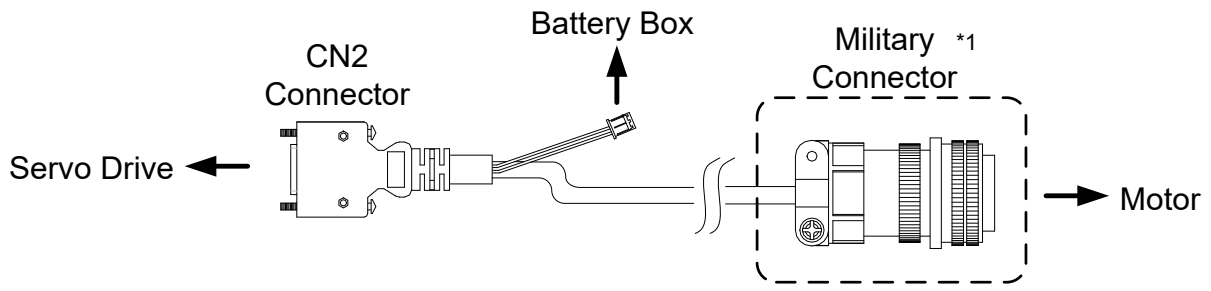

Note*1

View from this side

Pin No.	Assignment	Color
A	T+	White
B	T-	White/Red
C	BAT+	Red
D	BAT-	Black
S	DC+5V	Brown
R	GND	Blue
L	BRAID SHIELD	-

3106A-20-29S
Military Connector

3.1.6 Selection of Wiring Rod

The recommended wire rods are shown as the following table.

Servo Drive and corresponding Servo Motor		Power Wiring - Wire Diameter mm ² (AWG)							
		L _{1C} , L _{2C}	R, S, T	U, V, W	P ⁺ , C				
ASD-A2-0121-□	ECMA-C1040F□S	1.3 (AWG16)	2.1 (AWG14)	0.82 (AWG18)	2.1 (AWG14)				
	ECMA-CΔ0401□S								
ASD-A2-0221-□	ECMA-CΔ0602□S								
ASD-A2-0421-□	ECMA-CΔ0604□S								
	ECMA-CΔ0604□H								
	ECMA-CΔ0804□7								
	ECMA-EΔ1305□S								
	ECMA-GΔ1303□S								
ASD-A2-0721-□	ECMA-FΔ1305□S								
	ECMA-CΔ0807□S								
	ECMA-CΔ0807□H								
	ECMA-CΔ0907□S								
	ECMA-GΔ1306□S								
ASD-A2-1021-□	ECMA-CΔ0910□S					1.3 (AWG16)	2.1 (AWG14)	1.3 (AWG16)	2.1 (AWG14)
	ECMA-CΔ1010□S								
	ECMA-EΔ1310□S								
	ECMA-FΔ1308□S								
	ECMA-GΔ1309□S								
ASD-A2-1521-□	ECMA-EΔ1315□S								
ASD-A2-2023-□	ECMA-CΔ1020□S	1.3 (AWG16)	2.1 (AWG14)	2.1 (AWG14)	2.1 (AWG14)				
	ECMA-EΔ1320□S								
	ASD-A2-3023-□	ECMA-EΔ1820□S	1.3 (AWG16)	2.1 (AWG14)	3.3 (AWG12)	2.1 (AWG14)			
		ECMA-FΔ1313□S							
		ECMA-FΔ1318□S							
ASD-A2-3023-□	ECMA-CΔ1330□S								
	ECMA-EΔ1830□S								
	ECMA-EΔ1835□S								
	ECMA-FΔ1830□S								
ASD-A2-4523-□	ECMA-FΔ1845□S	1.3 (AWG16)	3.3 (AWG12)	8.4 (AWG8)	3.3 (AWG12)				
ASD-A2-5523-□	ECMA-FΔ1855□3	1.3 (AWG16)	3.3 (AWG12)	13.3 (AWG6)	3.3 (AWG12)				
ASD-A2-7523-□	ECMA-FΔ1875□3	1.3 (AWG16)	5.3 (AWG10)	13.3 (AWG6)	3.3 (AWG12)				

Servo Drive and corresponding Servo Motor		Power Wiring - Wire Diameter mm ² (AWG)			
		L _{1C} , L _{2C}	R, S, T	U, V, W	P [⊕] , C
ASD-A2-1B23-□	ECMA-F1221B□3	1.3 (AWG16)	8.4 (AWG8)	13.3 (AWG6)	8.4 (AWG8)
ASD-A2-1F23-□	ECMA-F1221F□S	1.3 (AWG16)	13.3 (AWG6)	21.2 (AWG4)	13.3 (AWG6)

Servo Drive Model	Encoder Wiring - Wire Diameter mm ² (AWG)			
	Size	Number	Specification	Standard Length
ASD-A2-0121-□	Note*8	2C+2P	L = 3 to 20 m (UL2464) L = 21 to 50 m (UL20276)	L = 3 to 20 m (9.84 ft to 65.6 ft) L = 21 to 50 m (68.9 ft to 164 ft)
ASD-A2-0221-□				
ASD-A2-0421-□				
ASD-A2-0721-□				
ASD-A2-1021-□				
ASD-A2-1521-□				
ASD-A2-2023-□				
ASD-A2-3023-□				
ASD-A2-4523-□				
ASD-A2-5523-□				
ASD-A2-7523-□				
ASD-A2-1B23-□				
ASD-A2-1F23-□				

Note:

- Please use shielded twisted-pair cable for encoder wiring so as to reduce the interference of the noise.
- The shield should connect to the \ominus phase of SHIELD.
- Please follow the Selection of Wire Rod when wiring in order to avoid the danger it may occur.
- Box, (□) at the end of the servo drive model represents the model code of ASDA-A2. Please refer to the model information of the product you purchased.
- (Δ), in servo motor model represents encoder type. Δ= 1: incremental type, 20-bit; Δ= 2: incremental type, 17-bit; Δ = 3: 2500 ppr; Δ= A: absolute type.
- Box, (□) in servo motor model represents brake or keyway / oil seal.
- Specification of brake cable F40 to F86: AWG#22; specification of brake cable for F100 or above: AWG#20.
- L = 3 - 20 m: 0.324 mm²-2C(AWG22-2C) – for connecting to +5V power and grounding
0.205 mm²-2P(AWG24-2P) – for signal cable
L = 21 - 50 m: 1.31 mm²-2C(AWG16-2C) – for connecting to +5V power and grounding
0.128 mm²-2P(AWG26-2P) – for signal cable

3.2 Connections - 400V series

3.2.1 Connecting to Peripheral Devices

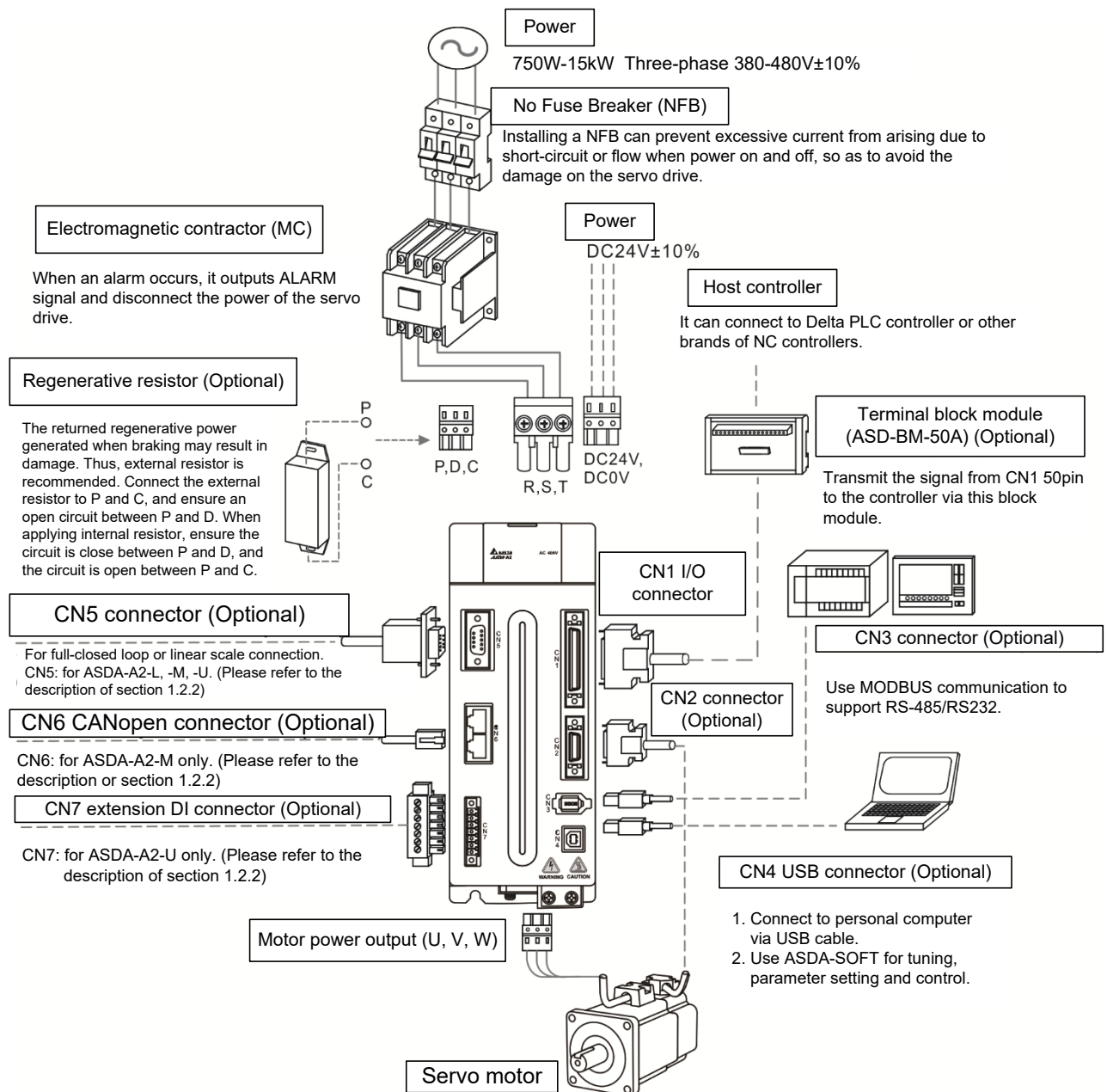

Installation Notes:

1. Check if the power and wiring among R, S, T and DC24V, DC0V are correct.
Please refer to Chapter 11 for Specifications. Make sure the input voltage is correct, or it might damage the servo drive or danger may occur.
2. Check if the output terminal U, V, W of the servo motor is correctly wired. The incorrect wiring may disable the operation of the motor or cause the malfunction.
3. When applying to the external regenerative resistor, the contact between P⁺ and D should be opened and the external regenerative resistor should connect to terminal P⁺ and C. When applying to the internal regenerative resistor, the contact between P⁺ and D should be closed and the contact between P⁺ and C should be opened.
4. When an alarm occurs or the system is in emergency stop status, use ALARM or WARN to output and disconnect the power of magnetic contactor in order to disconnect the power of servo drive.

3.2.2 Connectors and Terminals of the Servo Drive

Terminal Signal	Name	Description		
DC24V, DC0V	Power input of the control circuit	Connect to single-phase AC power (select the appropriate voltage specification according to the product)		
R, S, T	Power input of the main circuit	Connect to three-phase AC power (select the appropriate voltage specification according to the product)		
U, V, W FG (⊕)	Motor cable	Connect to servo motor		
		Terminal Symbol	Wire Color	Description
		U	Red	Three-phase main power cable of the motor
		V	White	
		W	Black	
FG(⊕)	Green	Connect to the grounding ⊕ of the servo drive.		
P⊕, D, C, ⊖	Regenerative resistor terminal or braking unit	Internal resistor	The contact between P⊕ and D end should be closed; contact between P⊕ and C end should be opened.	
		External resistor	Connect P⊕, C ends to the resistor and the contact between P⊕ and D end should be opened.	
		External braking unit	P⊕ and P⊖ of the brake unit should connect to P⊕ and P⊖ respectively. The contact between P⊕ and D and P⊕ and C should be opened. P⊕: Connect (+) terminal of V_BUS voltage. ⊖: Connect to (-) terminal of V_BUS voltage.	
⊕	Ground terminal	Connect to the ground wire of the power and the servo motor.		
CN1	I/O connector (Optional)	Connect to the host controller. Please refer to Section 3.4.		
CN2	Connector (Optional)	Connect to the encoder of the motor. Please refer to Section 3.5.		
CN3	Connector (Optional)	Connect to RS-485 or RS-232. Please refer to Section 3.6.		
CN4	USB connector (Type B) (Optional)	Connect to personal computer (PC or NOTEBOOK). Please refer to Section 3.7.		
CN5	Connector (Optional)	Connect to linear scale or encoder for full-closed loop and motor feedback. Please refer to Section 3.8.		

Terminal Signal	Name	Description
CN6	CANopen connector (Optional)	RJ45 connector. Please refer to Section 3.9
CN7	Extension DI connector (Optional)	Extension DI connector. Please refer to 3.10.
CN8	Reserved connector	Reserved.
CN9	Communication extension port (Optional)	For other expansion cards (coming soon).

Pay special attention to the followings when wiring:

1. When the power is cutoff, do not touch R, S, T and U, V, W since the capacitance inside the servo drive still contains huge amount of electric charge. Wait until the charging light is off.
2. Separate R, S, T and U, V, W from the other wires. The interval should be at least 30 cm (11.8 inches).
3. If the wire of encoder CN2 or CN5 connector is not long enough, please use shielded twisted-pair cable which cannot exceed 20 meters (65.62 feet). If it exceeds 20 meters, please choose the bigger wire diameter of signal cable to ensure it will not cause signal fading. As for the encoder wiring specification of 20-meter-long cable, please use AWG26 of wire size and metal braided shield twisted-pair cable which complies with the standard of UL2464.
4. When using CANopen, please use the standard shielded twisted-pair cables to ensure the communication quality.
5. When selecting the wire rod, please refer to Section 3.2.6.
6. Do not install the plug-in capacitance in servo drive. It might burn out the soft-start resistance and cause danger.

3.2.3 Wiring Method

The wiring method of 400V servo drive is divided into single-phase and three-phase. In the diagram below, Power On is contact **a**, and Power Off and ALRM_RY are contact **b**. MC is the coil of magnetic contactor, self-remaining power, and the contact of main power circuit.

- Wiring Method of Three-phase Power Supply (suitable for all series of 400V servo drive)

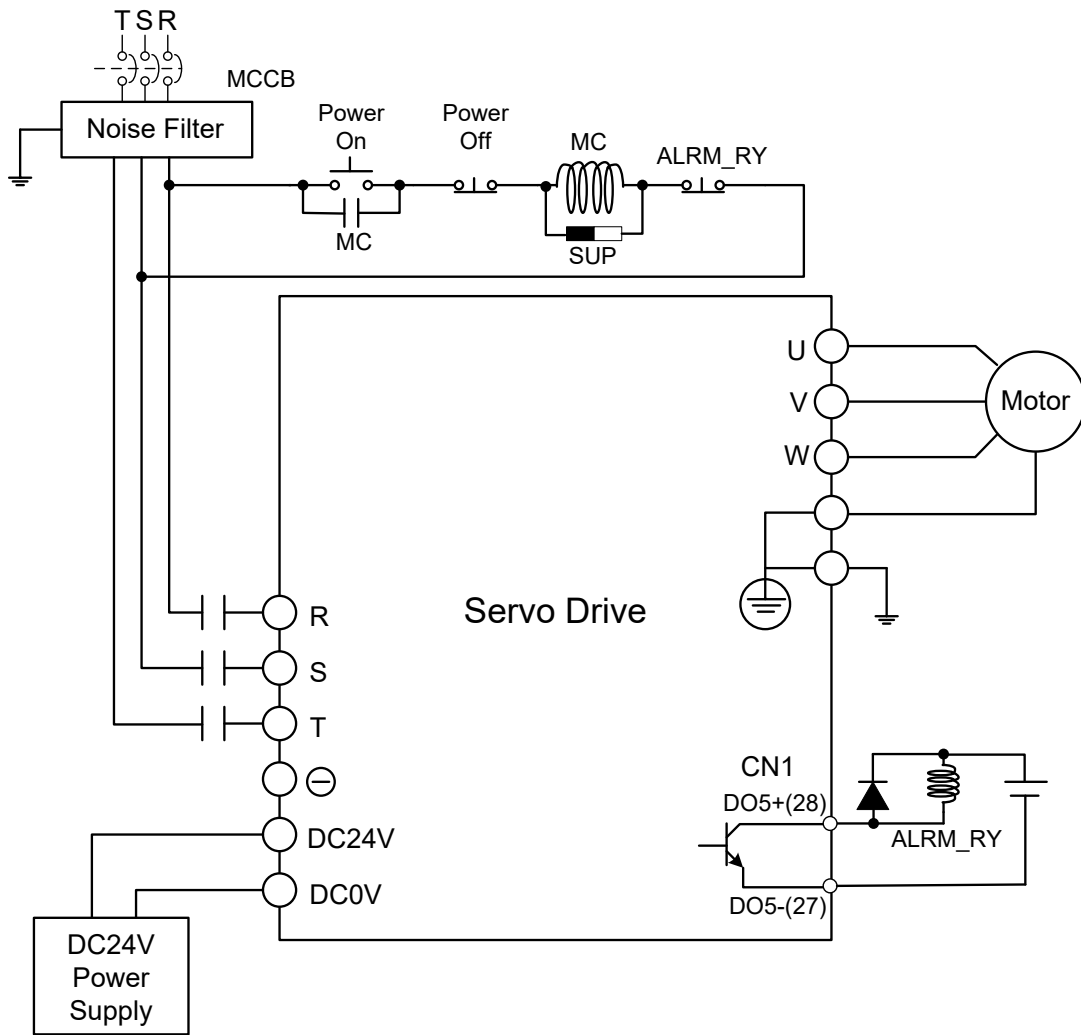

3.2.4 Specification of Motor Power Cable

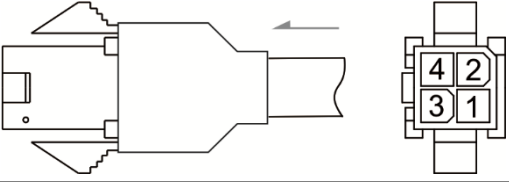
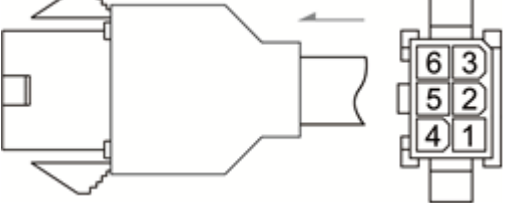
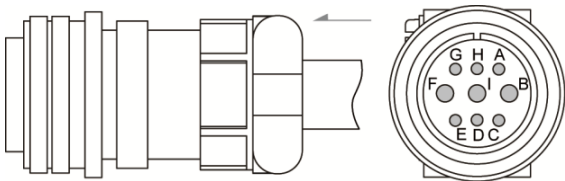
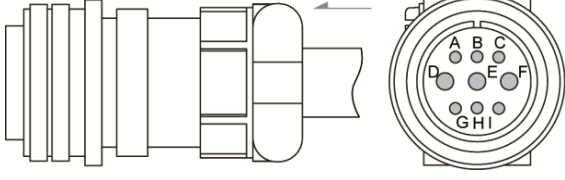
Motor Model	U, V, W / Connector of Brake	Terminal Definition
ECMA-J Δ 0604□S (400 W) ECMA-J Δ 0807□S (750 W) ECMA-J Δ 0907□S (750 W) ECMA-J Δ 0910□S (1000 W)		A
ECMA-J Δ 0604□S (400 W) ECMA-J Δ 0807□S (750 W) ECMA-J Δ 0907□S (750 W) ECMA-J Δ 0910□S (1000 W)		B
ECMA-K Δ 1305□S (500 W) ECMA-L Δ 1305□S (500 W) ECMA-L Δ 1308□S (850 W) ECMA-M Δ 1309□S (900 W) ECMA-J Δ 1010□S (1000 W) ECMA-K Δ 1310□S (1000 W) ECMA-L Δ 1313□S (1300 W) ECMA-K Δ 1315□S (1500 W) ECMA-J Δ 1020□S (2000 W) ECMA-K Δ 1320□S (2000 W) ECMA-J Δ 1330□4 (3000 W)		C
ECMA-L Δ 1830□S (3000 W) ECMA-L Δ 1845□S (4500 W) ECMA-L Δ 1855□3 (5500 W) ECMA-L Δ 1875□3 (7500 W) ECMA-K Δ 1820□S (2000 W)		D

Wiring Name	U (Red)	V (White)	W (Black)	CASE GROUND (Yellow/Green)	BRAKE1 (Note*5)	BRAKE2 (Note*5)
A	1	2	3	4	-	-
B	1	2	4	5	3	6
C	F	I	B	E	G	H
D	D	E	F	G	A	B

When selecting the wire rod, please choose 600V_{AC} PVC cable and the length should not be longer than 30 m (98.43 feet). If the length exceeds 30 m, please refer to the voltage drop when selecting the wire size. Please refer to Section 3.1.6 for wire rod selection.

Note:

1. No polarity for brake coil. The wiring name is BRAKE1 & BRAKE2.
2. Power for brake is DC24 V. Never share it with the power of control signal VDD.
3. Box, (Δ) in servo motor model represents encoder type. $\Delta=1$: incremental, 20-bit; $\Delta=2$: incremental, 17-bit; $\Delta=3$: 2500 ppr; $\Delta=A$: absolute.
4. Box, (\square) in servo motor model represents brake or keyway / oil seal.
5. Color of brake cable F40 to F86: brown and blue; color of brake cable for F100 or above: yellow and blue.

3.2.5 Specification of Encoder Connector

Encoder Connection (Diagram 1):

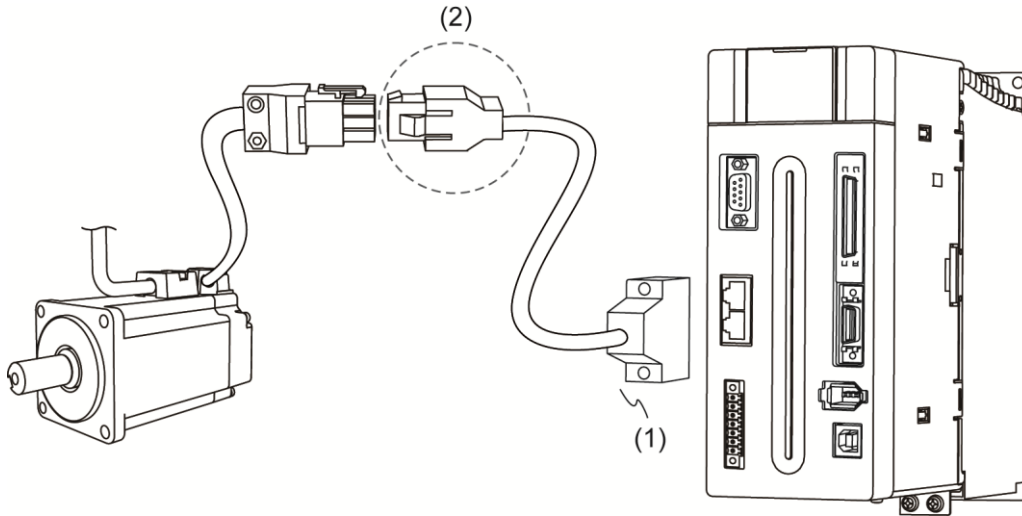

(1) CN2 connector; (2) Quick connector (connector of encoder cable)

Note: This diagram shows the connection between the servo drive and the motor encoder. It is not drawn by the practical scale and specification will be different according to the selected servo drive and motor model.

1. Please refer to the Section of Specification and Definition of Encoder Connector.
2. Please refer to Section 3.5 CN2 Connector.

Motor Model	Connector of Encoder Cable
ECMA-JΔ0604□S (400 W) ECMA-JΔ0807□S (750 W) ECMA-JΔ0907□S (750 W) ECMA-JΔ0910□S (1000 W)	

Encoder Connection (Diagram 2):

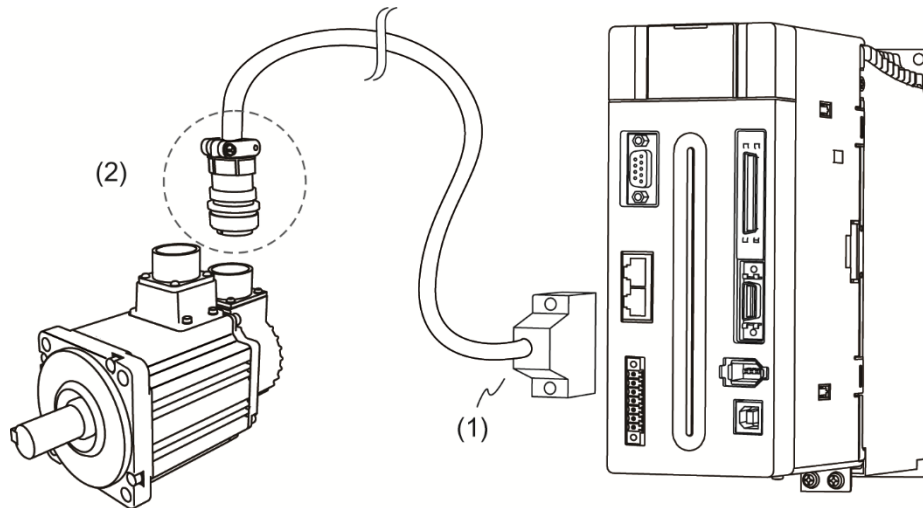

(1) CN2 connector; (2) Military connector (connector of encoder cable)

Note: This diagram shows the connection between the servo drive and the motor encoder. It is not drawn by the practical scale and specification will be different according to the selected servo drive and motor model.

Please refer to Section 3.5, CN2 Connector.

Motor Model	Connector of Encoder Cable			
ECMA-K Δ 1305□S (500 W)		Pin No.	Terminal Identification	Color
ECMA-L Δ 1305□S (500 W)		A	T+	White
ECMA-L Δ 1308□S (850 W)		B	T-	White/Red
ECMA-M Δ 1309□S (900 W)		S	DC+5V	Brown
ECMA-J Δ 1010□S (1000 W)		R	GND	Blue
ECMA-K Δ 1310□S (1000 W)		L	BRAID SHIELD	-
ECMA-L Δ 1313□S (1300 W)				
ECMA-K Δ 1315□S (1500 W)				
ECMA-J Δ 1020□S (2000 W)				
ECMA-K Δ 1320□S (2000 W)				
ECMA-J Δ 1330□4 (3000 W)				

Please select shielded multi-core and the shielded cable should connect to the SHIELD end.

Please refer to the description of Section 3.1.6.

Note:

- The symbol Δ in the servo motor model represents encoder type.
 - Δ = 1: incremental, 20-bit; Δ = 2: incremental, 17-bit; Δ = 3: 2500 ppr;
 - Δ = A: absolute
- The box □ in the servo motor model represents brake or keyway / oil seal.

3.2.6 Selection of Wiring Rod

The following table lists the recommended wire for connectors and signal wiring for the ASDA-A2 servo drive.

Servo Drive and corresponding Servo Motor		Power Wiring - Wire Diameter mm ² (AWG)			
		DC24V, DC0V	R, S, T	U, V, W	P ⁺ , C
ASD-A2-0743-□	ECMA-J Δ 0604□S	1.3 (AWG16)	0.82 (AWG18)	0.82 (AWG18)	2.1 (AWG14)
	ECMA-J Δ 0807□S				
	ECMA-J Δ 0907□S				
	ECMA-K Δ 1305□S				
	ECMA-L Δ 1305□S				
ASD-A2-1043-□	ECMA-J Δ 0910□S	1.3 (AWG16)	0.82 (AWG18)	1.3 (AWG16)	2.1 (AWG14)
	ECMA-K Δ 1310□S				
	ECMA-L Δ 1308□S				
ASD-A2-1543-□	ECMA-J Δ 1010□S	1.3 (AWG16)	0.82 (AWG18)	1.3 (AWG16)	2.1 (AWG14)
	ECMA-K Δ 1315□S				
	ECMA-M Δ 1309□S				
	ECMA-L Δ 1313□S				
ASD-A2-2043-□	ECMA-J Δ 1020□S	1.3 (AWG16)	0.82 (AWG18)	1.3 (AWG16)	2.1 (AWG14)
	ECMA-K Δ 1320□S				
	ECMA-K Δ 1820□S				
ASD-A2-3043-□	ECMA-L Δ 1830□S	1.3 (AWG16)	1.3 (AWG16)	1.3 (AWG16)	2.1 (AWG14)
	ECMA-J Δ 1330□4				
ASD-A2-4543-□	ECMA-L Δ 1845□S	1.3 (AWG16)	2.1 (AWG14)	3.3 (AWG12)	3.3 (AWG12)
ASD-A2-5543-□	ECMA-L Δ 1855□3	1.3 (AWG16)	3.3 (AWG12)	5.3 (AWG10)	3.3 (AWG12)
ASD-A2-7543-□	ECMA-L Δ 1875□3	1.3 (AWG16)	13.3 (AWG6)	13.3 (AWG6)	10.5 (AWG7)
ASD-A2-1B43-□	ECMA-L Δ 1875□3	1.3 (AWG16)	13.3 (AWG6)	13.3 (AWG6)	10.5 (AWG7)
	ECMA-L Δ 221B□3				
	ECMA-L Δ 221F□3				
ASD-A2-1F43-□	ECMA-L Δ 221B□3	1.3 (AWG16)	13.3 (AWG6)	13.3 (AWG6)	10.5 (AWG7)
	ECMA-L Δ 221F□3				

Servo Drive Model	Encoder Wiring - Wire Diameter mm ² (AWG)			
	Size	Number	Specification	Standard Length
ASD-A2-0743-□	Note*7	2C+2P	L = 3 to 20 m (UL2464) L = 21 to 50 m (UL20276)	L = 3 to 20 m (9.84 ft to 65.6 ft) L = 21 to 50 m (68.9 ft to 164 ft)
ASD-A2-1043-□				
ASD-A2-1543-□				
ASD-A2-2043-□				
ASD-A2-3043-□				
ASD-A2-4543-□				
ASD-A2-5543-□				
ASD-A2-7543-□				
ASD-A2-1B43-□				
ASD-A2-1F43-□				

Note:

1. Box, (□) at the end of the servo drive model represents the model code of ASDA-A2. Please refer to the model information of the product you purchased.
2. (Δ), in servo motor model represents encoder type. Δ= 1: incremental type, 20-bit; Δ= 2: incremental type, 17-bit; Δ= 3: 2500 ppr; Δ= A: absolute type.
3. Box, (□) in servo motor model represents brake or keyway / oil seal.
4. Please use shielded twisted-pair cable for encoder wiring so as to reduce the interference of the noise.
5. The shield should connect to the \ominus phase of SHIELD.
6. Please follow the Selection of Wire Rod when wiring in order to avoid the danger it may occur.
7. L = 3 - 20 m: 0.324 mm²-2C(AWG22-2C) – for connecting to +5V power and grounding
0.205 mm²-2P(AWG24-2P) – for signal cable

L = 21 - 50 m: 1.31 mm²-2C(AWG16-2C) – for connecting to +5V power and grounding
0.128 mm²-2P(AWG26-2P) – for signal cable

3.3 Basic Wiring

3.3.1 220V series

- 200 W (included) or models below (without built-in regenerative resistor)

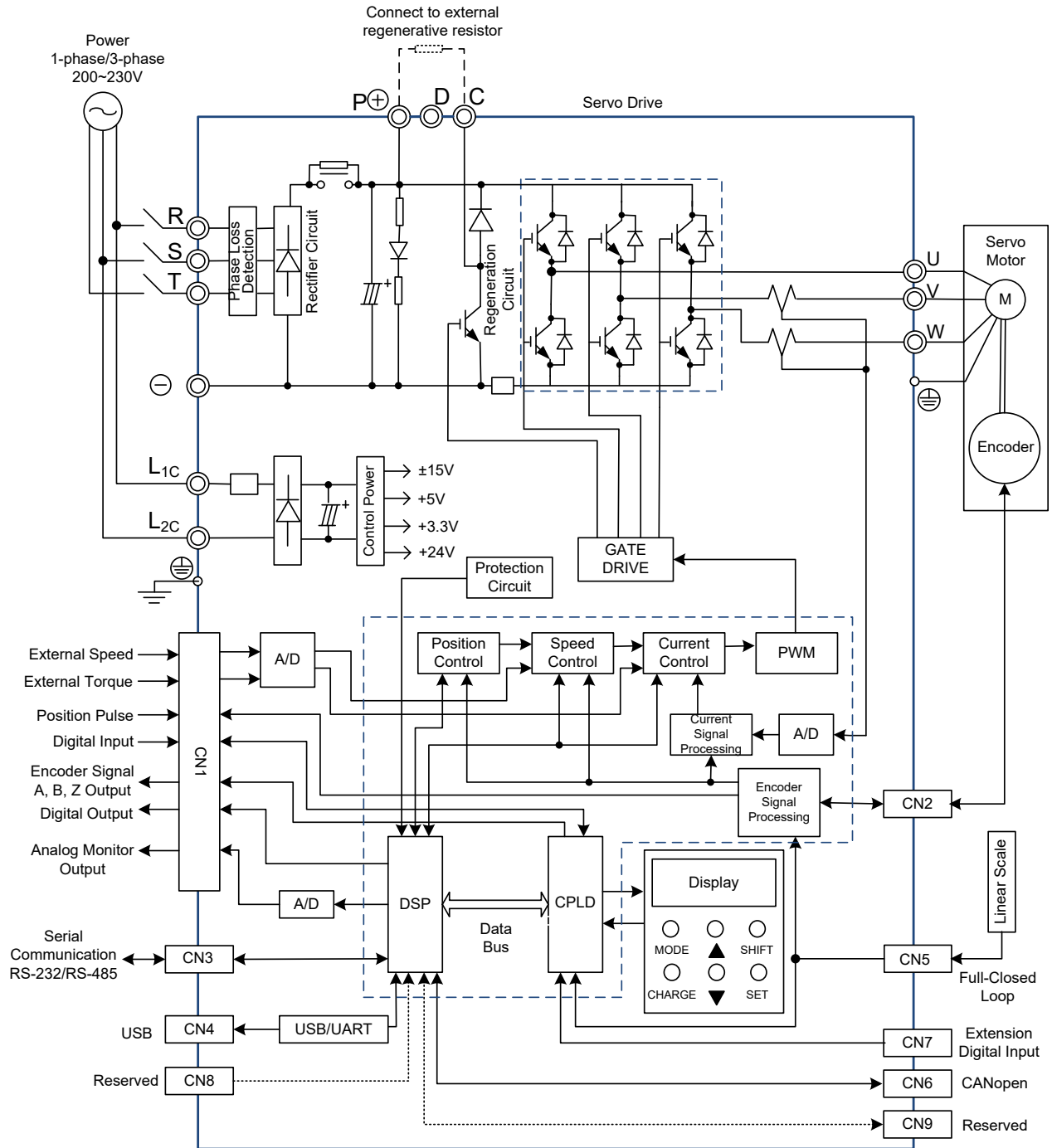

■ 400 W ~ 4.5 kW models (with built-in regenerative resistor)

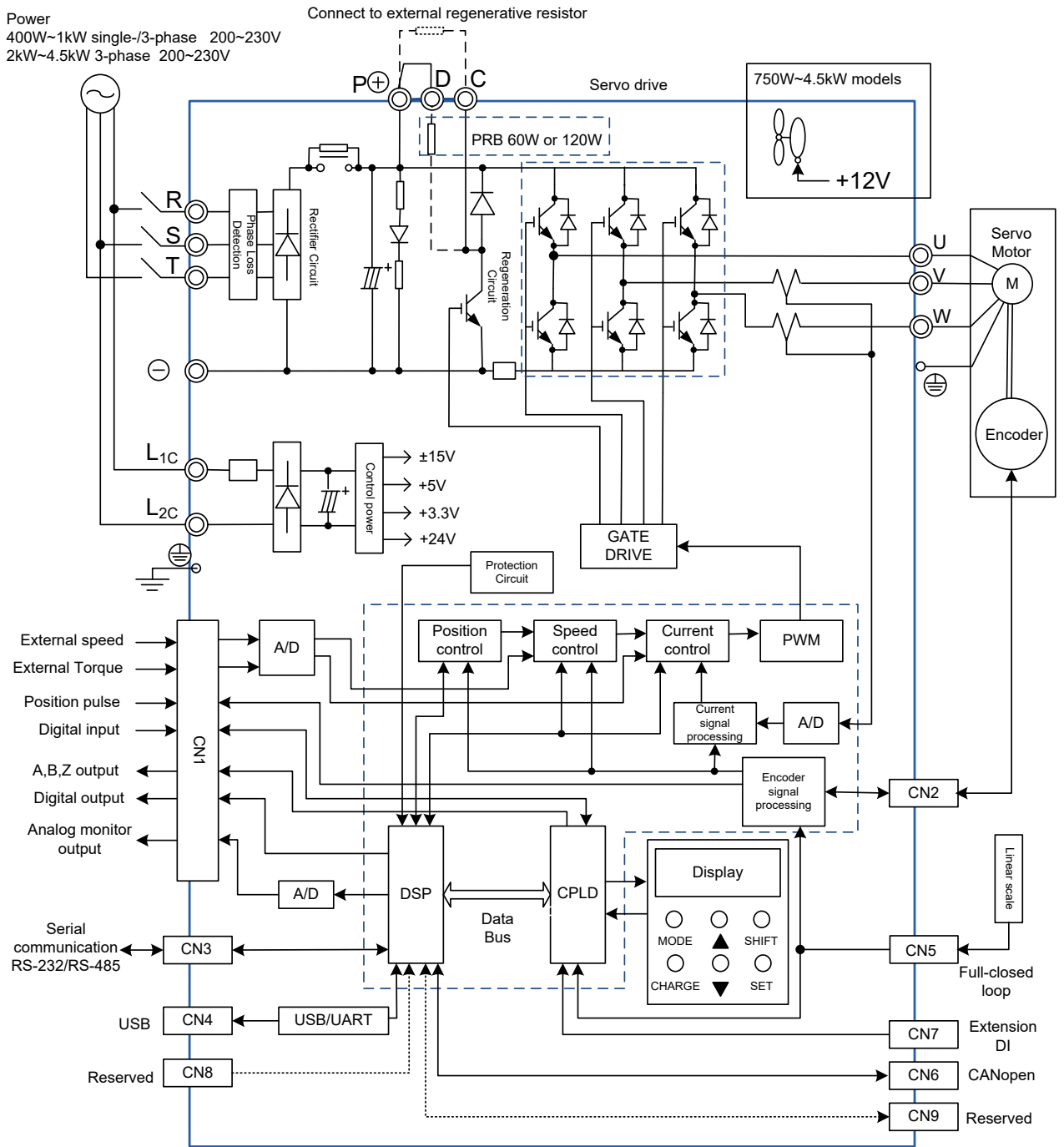

■ 5.5 kW ~ 15 kW models (with built-in fan but no regenerative resistor)

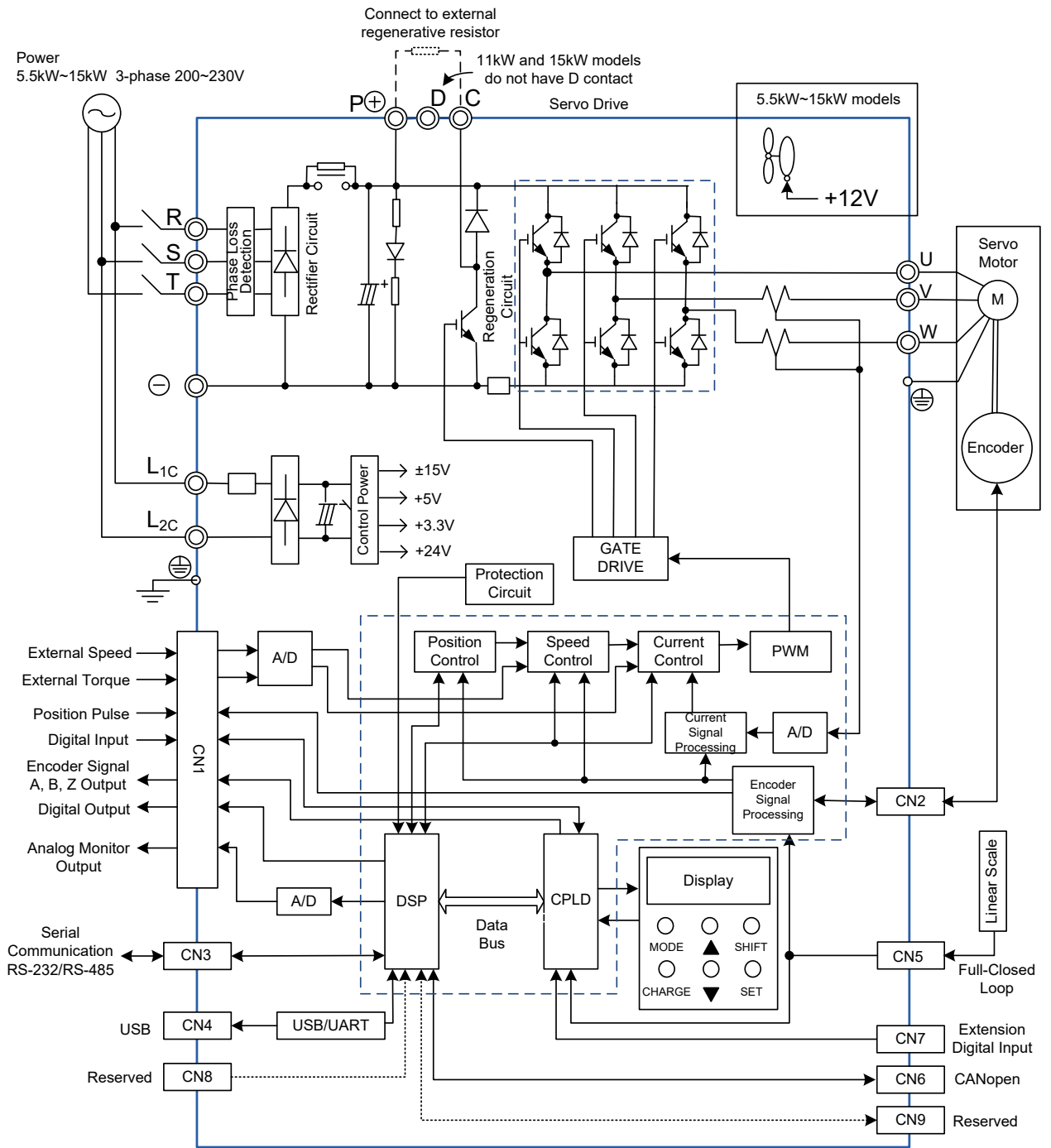

3.3.2 400V series

- 750 W ~ 1.5 kW models (with built-in regenerative resistor and fan)

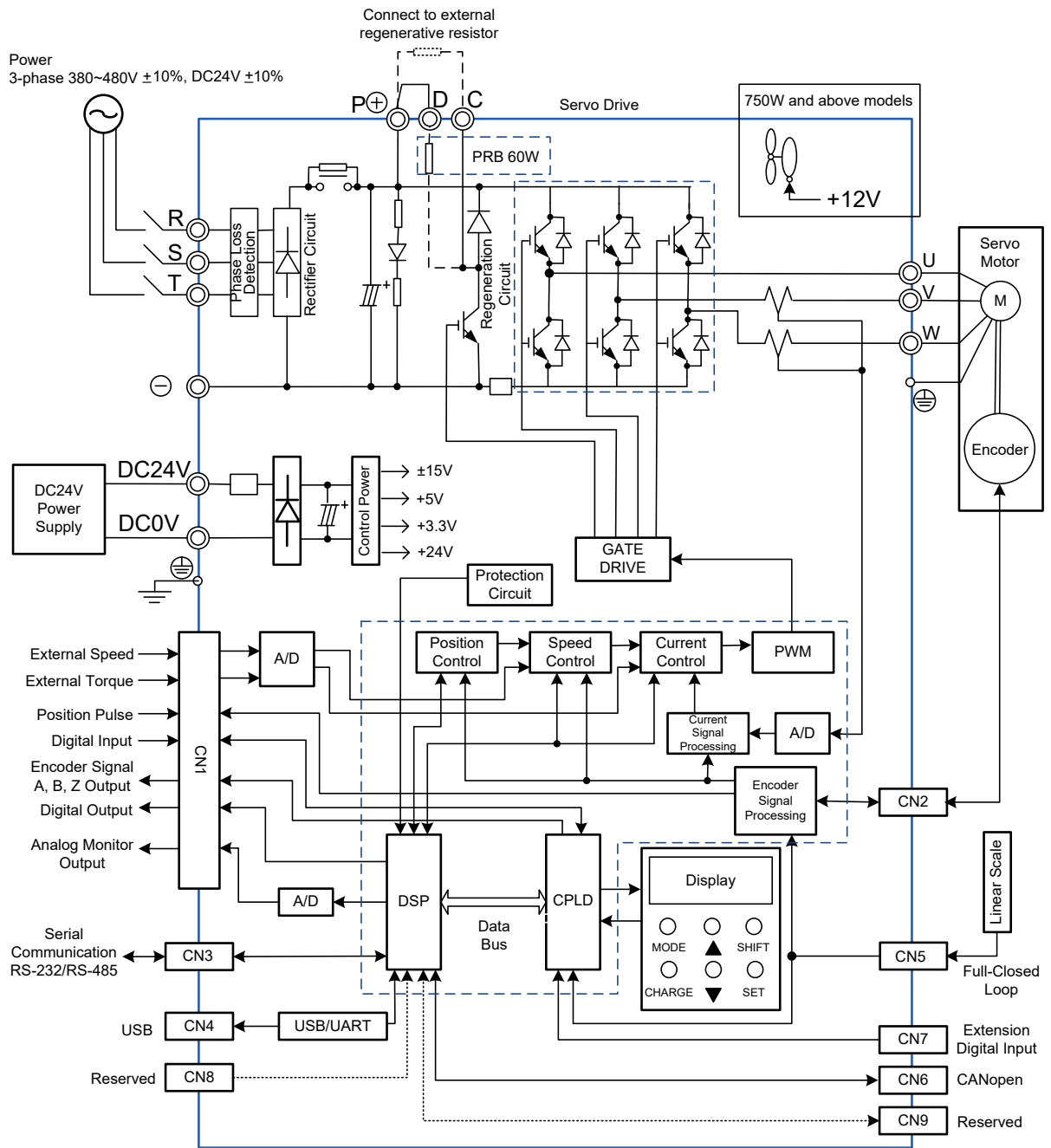

■ 2 kW ~ 7.5 kW models (with built-in fan but no regenerative resistor)

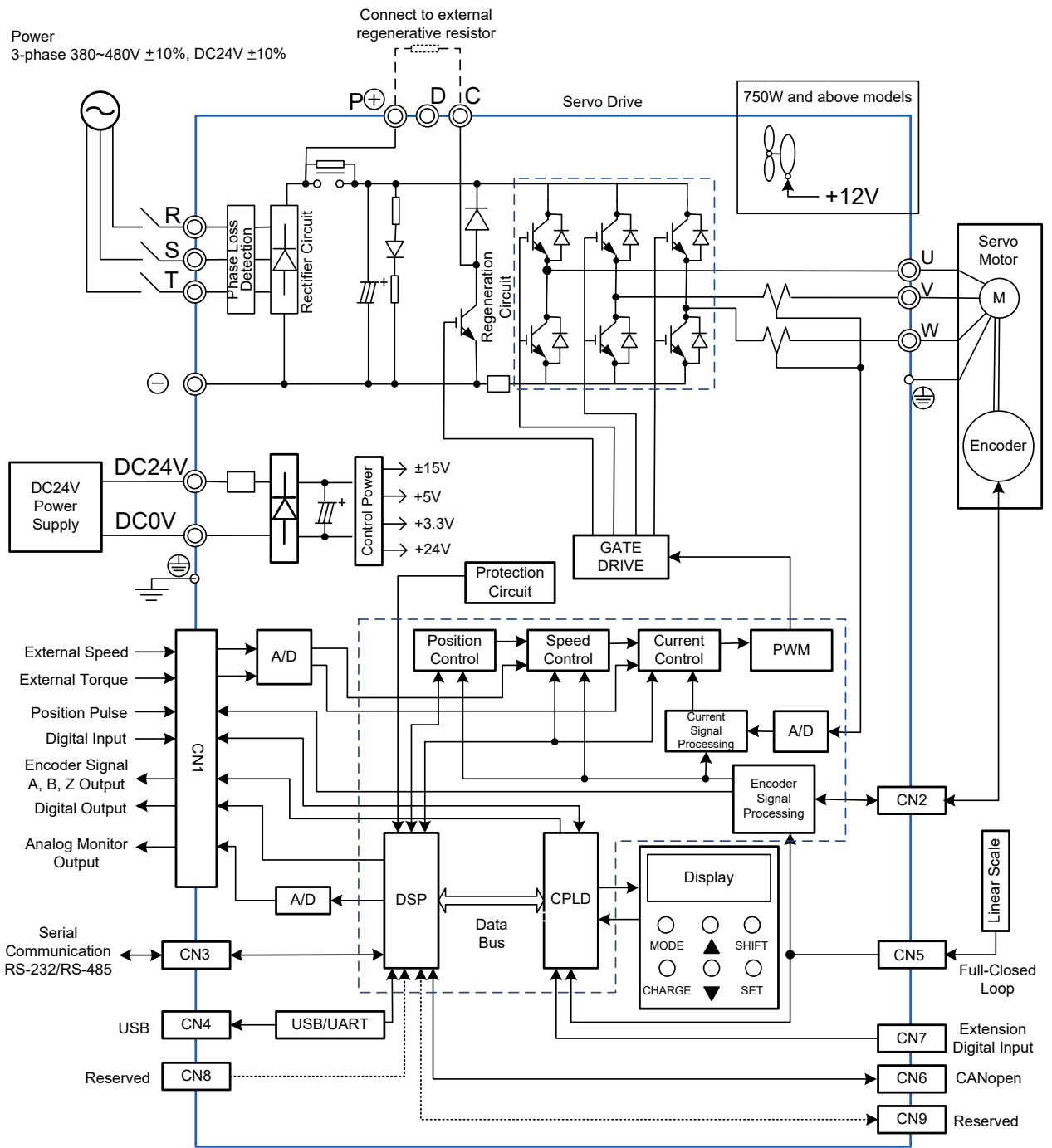

3.4 I/O Signal (CN1) Connection

3.4.1 I/O Signal (CN1) Connector Terminal Layout

In order to have a more flexible communication with the controller, 5 programmable Digital Outputs (DO) and 8 programmable Digital Inputs (DI) are provided. The setting of 8 digital inputs and 5 digital outputs of each axis are parameters P2-10 ~ P2-17 and parameters P2-18 ~ P2-22 respectively. In addition, the differential output encoder signal, A+, A-, B+, B-, Z+, and Z-, inputs of analog torque command, analog speed/position command, and pulse position command are also provided. The pin diagram is as follows.

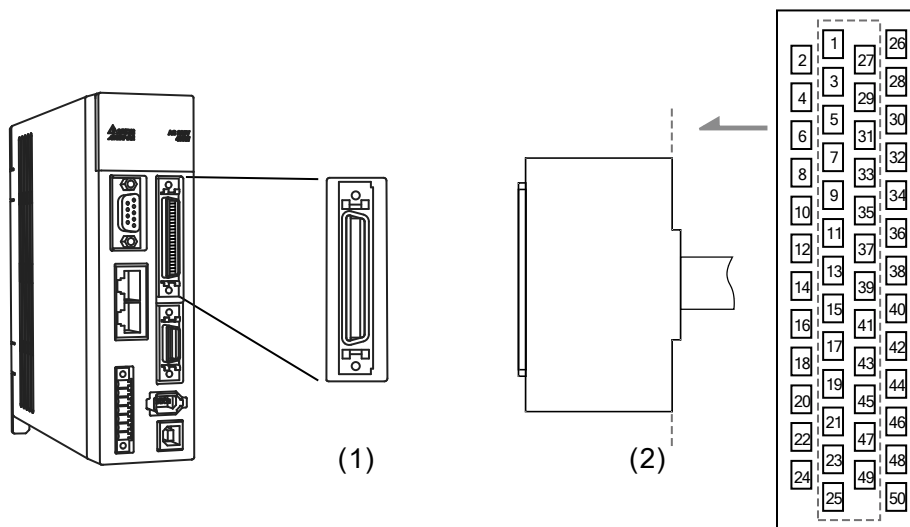

(1) CN1 connector (Female); (2) CN1 connector (Male)

Pin assignment:

2	DO3-	Digital output	1	DO4+	Digital output	26	DO4-	Digital output
4	DO2-	Digital output	3	DO3+	Digital output	27	DO5-	Digital output
6	DO1-	Digital output	5	DO2+	Digital output	28	DO5+	Digital output
8	DI4-	Digital input	7	DO1+	Digital output	29	/HPULSE	High-speed position pulse (-)
10	DI2-	Digital input	9	DI1-	Digital input	30	DI8-	Digital input
12	GND	Analog input signal ground	11	COM+	Power input (12~24V)	31	DI7-	Digital input
14	NC	No Connection	13	GND	Analog input signal ground	33	DI5-	Digital input
16	MON1	Analog monitor output 1	15	MON2	Analog monitor output 2	35	PULL HI_S (SIGN)	Pulse applied power (SIGN)
18	T_REF	Analog torque Input	17	VDD	+24V power output (for external I/O)	37	/SIGN	Position sign (-)
20	VCC	+12V power output (for analog command)	19	GND	Analog input signal ground	39	PULL HI_P (PULSE)	Pulse applied Power (PULSE)
22	/OA	Encoder /A pulse output	21	OA	Encoder A pulse output	41	/PULSE	Pulse input (-)
24	/OZ	Encoder /Z pulse output	23	/OB	Encoder /B pulse output	43	PULSE	Pulse input (+)
			25	OB	Encoder B pulse output	45	COM-	VDD(24V) power ground
						47	COM-	VDD(24V) power ground
						49	COM-	VDD(24V) power ground
						46	HSIGN	High-speed position sign (+)
						48	OCZ	Encoder Z pulse open-collector output
						50	OZ	Encoder Z pulse line-driver output
						42	V_REF	Analog speed input (+)
						38	HPULSE	High-speed position pulse (+)
						36	SIGN	Position sign (+)
						34	DI3-	Digital input
						32	DI6-	Digital input

Note: NC means NO CONNECTION. This terminal is for internal use only. Do not connect it, or it may damage the servo drive.

3.4.2 Signals Explanation of Connector CN1

The following details the signals listed in the previous section:

General Signals

Signal		Pin No.	Function	Wiring Method (Refer to section 3.4.3)
Analog Command (input)	V_REF	42	(1) The speed command of the motor is -10V ~ +10V which means the speed command is -3000 ~ +3000 r/min (default). It can change the corresponding range via parameters. (2) The position command of the motor is -10V ~ +10V which means the position command is -3 cycles ~ +3 cycles (default).	C1
	T_REF	18	The torque command of the motor is -10V ~ +10V which means the rated torque command of -100 % ~ +100 %.	C1
Analog Monitor (output)	MON1 MON2	16 15	The operating state of the motor can be shown by analog voltage, such as speed and current. This drive provides two channel outputs. Users can select the desired monitoring data via parameter P0-03. This signal is based on the power ground.	C2
Position Pulse (input)	PULSE	43	Position pulses can be sent by Line Driver (single-phase max. frequency 500 kHz) or open-collector (single phase max. frequency 200 kHz). The command types can be selected with P1-00, CW/CCW pulse, pulse and direction, and A/B pulse. If open collector type is used with sending position pulses, CN1 should be connected to an external applied power for pull high.	C3/C4
	/PULSE	41		
	SIGN	36		
	/SIGN	37		
	PULL HI_P	39		
PULL HI_S	35			
High-speed Position Pulse (input)	HPULSE	38	Position pulses can only be sent by Line Driver (single-phase max. frequency 4 MHz). Three command types are available, CW/CCW pulse, pulse with direction, and A/B pulse; please refer to P1-00.	C4-2
	/HPULSE	29		
	HSIGN	46		
	/HSIGN	40		
Position Pulse (output)	OA	21	Encoder signal output A, B, Z (Line Drive output)	C13/C14
	/OA	22		
	OB	25		
	/OB	23		
	OZ	50	Encoder signal output Z (Open-collector output)	-
	/OZ	24		
	OCZ	48		
Power	VDD	17	VDD is the +24V power provided by the drive and is for Digital Input (DI) and Digital Output (DO) signals. The maximum current is 500 mA.	-

Signal		Pin No.	Function	Wiring Method (Refer to section 3.4.3)
	COM+ COM-	11 45 47 49	COM+ is the common input of Digital Input (DI) and Digital Output (DO) voltage. When using VDD, VDD should be connected to COM+. If not using, it needs to apply the external power (+12V ~ + 24V). Its positive end should connect to COM+ and the negative end should connect to COM-.	
	VCC	20	VCC is the +12V power provided by the drive. It is used for providing the simple analog command (speed or torque command). The maximum current is 100 mA.	
	GND	12,13, 19,44	VCC voltage is based on GND.	
Other	NC	14	NO CONNECTION. This terminal is for internal use only. Do not connect it, or it may damage the servo drive.	

There are numerous operation modes of this servo drive (please refer to section 6.1). Each operation mode needs different I/O signals. In order to use the terminal in a more efficient way, the selection of I/O signal has to be programmable. That is to say, users can choose the desired DI/DO signal to meet the demand. Basically, the default setting of DI/DO signal has already had the appropriate function which can satisfy the demand of general applications.

Users have to select the operation mode based on the needs first (please refer to section 6.1 for the introduction of each mode) and refer to the following DI/DO table to know the corresponding default setting of DI/DO signal and Pin No. of the selected mode in order to conduct the wiring.

The table below lists the default setting of DI/DO signal function and Pin No.:

The explanation of DO signal default setting is as the followings.

DO Signal Name	Operation Mode	Pin No.		Details	Wiring Method (Refer to section 3.4.3)
		+	-		
SRDY	ALL	7	6	When the servo drive applies to the power and no alarm (ALRM) occurs in control circuit and motor power circuit, this DO is ON.	C5/C6/ C7/C8
SON	N/A	-	-	When the DI.SON is ON and the motor servo circuit can operate smoothly, this DO is ON.	
ZSPD	ALL	5	4	When the motor speed is slower than the setting value of parameter P1-38, this DO is ON.	
TSPD	ALL	-	-	When the motor actual speed (r/min) is faster than the setting value of parameter P1-39, this DO is ON.	
TPOS	PT, PR, PT-S, PT-T, PR-S, PR-T	1	26	When the deviation between the motor command and actual position (PULSE) is smaller than the setting value of parameter P1-54, this DO is ON.	C5/C6/ C7/C8
TQL	ALL (except T, Tz)	-	-	When torque is limiting, this DO is ON.	
ALRM	ALL	28	27	When the alarm occurs (except forward/reverse limit, emergency stop, communication error, under voltage), this DO is ON.	
BRKR	ALL	-	-	Control contact of brake.	
HOME	ALL	3	2	When homing is completed, this DO is ON.	
OLW	ALL	-	-	When the overload level is reached, this DO is ON.	
WARN	ALL	-	-	A warning occurs. When it is in the status of forward/reverse limit, emergency stop, communication error, under voltage, this DO is ON.	
OVF	PT, PR	-	-	Position command / feedback overflows	
SNL (SCWL)	PR	-	-	Reverse software limit	
SPL (SCCWL)	PR	-	-	Forward software limit	
Cmd_OK	PR	-	-	The output of internal position command is completed.	
CAP_OK	PR	-	-	CAPTURE procedure is completed.	
MC_OK	PR	-	-	When DO.Cmd_OK and TPOS are ON, this DO is ON.	
CAM_AREA	PR	-	-	The master position of E-CAM is inside the setting area.	

DO Signal Name	Operating Mode	Pin No.		Details	Wiring Method (Refer to section 3.4.3)
		+	-		
S_CMP	S, Sz	-	-	When the deviation between the speed command and the feedback speed of the motor is smaller than the setting value of parameter P1-47, this DO is ON.	
SDO_0	ALL	-	-	Output the status of bit00 of P4-06	
SDO_1	ALL	-	-	Output the status of bit01 of P4-06	
SDO_2	ALL	-	-	Output the status of bit02 of P4-06	
SDO_3	ALL	-	-	Output the status of bit03 of P4-06	
SDO_4	ALL	-	-	Output the status of bit04 of P4-06	
SDO_5	ALL	-	-	Output the status of bit05 of P4-06	
SDO_6	ALL	-	-	Output the status of bit06 of P4-06	
SDO_7	ALL	-	-	Output the status of bit07 of P4-06	
SDO_8	ALL	-	-	Output the status of bit08 of P4-06	
SDO_9	ALL	-	-	Output the status of bit09 of P4-06	
SDO_A	ALL	-	-	Output the status of bit10 of P4-06	
SDO_B	ALL	-	-	Output the status of bit11 of P4-06	
SDO_C	ALL	-	-	Output the status of bit12 of P4-06	
SDO_D	ALL	-	-	Output the status of bit13 of P4-06	
SDO_E	ALL	-	-	Output the status of bit14 of P4-06	
SDO_F	ALL	-	-	Output the status of bit15 of P4-06	

Note:

1. For example, if the user selects PR mode, Pin 3 and 2 are HOME. If the user selects S mode, Pin 3 and 2 are TSPD.
2. The unlisted Pin No. means the signal is not the preset one. If users want to use it, parameters need to be changed and set as the desired ones. Please refer to Section 3.4.4 for further details.

The explanation of DI signal default setting is as the followings

DI Signal Name	Operation Mode	Pin No.	Function	Wiring Method (Refer to section 3.4.3)
SON	ALL	9	When DI is ON, the servo circuit will be activated and the motor coil will generate current.	
ARST	ALL	33	When the alarm (ALRM) occurs, this signal is used to reset the servo drive and output the signal, Ready (SRDY), again.	C9/C10/ C11/C12
GAINUP	ALL	-	It is for switching the controller gain.	

DI Signal Name	Operation Mode	Pin No.	Function	Wiring Method (Refer to section 3.4.3)																																																																								
CCLR	PT, PR	10	It is for clearing the deviation counter.																																																																									
ZCLAMP	ALL	-	When this DI is ON and the motor speed is slower than the setting of P1-38, the motor position will be locked when the signal is triggered.																																																																									
CMDINV	S, Sz, T	-	When this DI is ON, the motor will operate in the opposite direction.																																																																									
CTRG	PR, PR-S, PR-T	10	In PR mode, the moment CTRG is ON (rising edge), save the position command selected by POS0 ~ 2 into the controller and then trigger the command.																																																																									
TRQLM	S, Sz	10	ON means the torque limit command is effective.																																																																									
SPDLM	T, Tz	10	ON means the speed limit command is effective.																																																																									
POS0	P, PR-S, PR-T	34	In PR mode, the source of position command:	C9/C10/ C11/C12																																																																								
POS1		8	<table border="1"> <thead> <tr> <th>Position command</th> <th>POS 5</th> <th>POS 4</th> <th>POS 3</th> <th>POS 2</th> <th>POS 1</th> <th>POS0</th> <th>CTRG</th> <th>Corresponding parameter</th> </tr> </thead> <tbody> <tr> <td>P0</td> <td>0</td> <td>0</td> <td>0</td> <td>0</td> <td>0</td> <td>0</td> <td>↑</td> <td>P6-00 P6-01</td> </tr> <tr> <td>P2</td> <td>0</td> <td>0</td> <td>0</td> <td>0</td> <td>0</td> <td>1</td> <td>↑</td> <td>P6-02 P6-03</td> </tr> <tr> <td>~</td> <td></td> <td></td> <td></td> <td></td> <td></td> <td></td> <td></td> <td>~</td> </tr> <tr> <td>P50</td> <td>1</td> <td>1</td> <td>0</td> <td>0</td> <td>1</td> <td>0</td> <td>↑</td> <td>P6-98 P6-99</td> </tr> <tr> <td>P51</td> <td>1</td> <td>1</td> <td>0</td> <td>0</td> <td>1</td> <td>1</td> <td>↑</td> <td>P7-00 P7-01</td> </tr> <tr> <td>~</td> <td></td> <td></td> <td></td> <td></td> <td></td> <td></td> <td></td> <td>~</td> </tr> <tr> <td>P63</td> <td>1</td> <td>1</td> <td>1</td> <td>1</td> <td>1</td> <td>1</td> <td>↑</td> <td>P7-26 P7-27</td> </tr> </tbody> </table>		Position command	POS 5	POS 4	POS 3	POS 2	POS 1	POS0	CTRG	Corresponding parameter	P0	0	0	0	0	0	0	↑	P6-00 P6-01	P2	0	0	0	0	0	1	↑	P6-02 P6-03	~								~	P50	1	1	0	0	1	0	↑	P6-98 P6-99	P51	1	1	0	0	1	1	↑	P7-00 P7-01	~								~	P63	1	1	1	1	1	1	↑	P7-26 P7-27
Position command		POS 5	POS 4		POS 3	POS 2	POS 1	POS0	CTRG	Corresponding parameter																																																																		
P0		0	0		0	0	0	0	↑	P6-00 P6-01																																																																		
P2		0	0		0	0	0	1	↑	P6-02 P6-03																																																																		
~										~																																																																		
P50		1	1		0	0	1	0	↑	P6-98 P6-99																																																																		
P51		1	1		0	0	1	1	↑	P7-00 P7-01																																																																		
~										~																																																																		
P63		1	1		1	1	1	1	↑	P7-26 P7-27																																																																		
POS2	-																																																																											
POS3	-																																																																											
POS4	-																																																																											
POS5	-																																																																											
STOP	-	-	Stop																																																																									
SPD0	S, Sz, PT-S, PR-S, S-T	34	The source of selecting speed command:																																																																									
SPD1		8	<table border="1"> <thead> <tr> <th>SPD1</th> <th>SPD0</th> <th>Command source</th> </tr> </thead> <tbody> <tr> <td>0</td> <td>0</td> <td>S mode is analog input; Sz mode is 0</td> </tr> <tr> <td>0</td> <td>1</td> <td>P1-09</td> </tr> <tr> <td>1</td> <td>0</td> <td>P1-10</td> </tr> <tr> <td>1</td> <td>1</td> <td>P1-11</td> </tr> </tbody> </table>	SPD1	SPD0	Command source	0	0	S mode is analog input; Sz mode is 0	0	1	P1-09	1	0	P1-10	1	1	P1-11																																																										
SPD1		SPD0	Command source																																																																									
0		0	S mode is analog input; Sz mode is 0																																																																									
0		1	P1-09																																																																									
1	0	P1-10																																																																										
1	1	P1-11																																																																										
TCM0	PT, T, Tz,	34	The source of selecting torque command:																																																																									

DI Signal Name	Operation Mode	Pin No.	Function			Wiring Method (Refer to section 3.4.3)
			TCM1	TCM0	Command source	
TCM1	PT-T, PR-T, S-T	8	TCM1	TCM0	Command source	
			0	0	T mode is analog input; Tz mode is 0	
			0	1	P1-12	
			1	0	P1-13	
			1	1	P1-14	
S-P	PT-S, PR-S	31	Mode switching. OFF: Speed; ON: Position			
S-T	S-T	31	Mode switching. OFF: Speed; ON: Torque			
T-P	PT-T, PR-T	31	Mode switching. OFF: Torque; ON: Position			
PT-PR	PT, PR	-	When selecting PT-PR mode or the multi-mode, PT-PR-S, users can select the source via this DI. When this DI is OFF, it is in PT mode. When this DI is ON, it is in PR mode.			
EMGS	ALL	30	It is contact B and has to be ON frequently; otherwise the alarm (ALRM) will occur.			
NL(CWL)	PT, PR, S, T, Sz, Tz	32	Reverse inhibit limit (contact B) and has to be ON frequently, or the alarm (ALRM) will occur.			
PL (CCWL)	PT, PR, S, T, Sz, Tz	31	Forward inhibit limit (contact B) and has to be ON frequently, or the alarm (ALRM) will occur.			
ORGP	PR	-	When this DI is ON, the drive will start homing.			
SHOM	PR	-	In PR mode, it needs to search the origin. When this DI is ON, the origin searching function is activated. (Please refer to the setting of parameter P1-47.)			
CAM	PR	-	E-cam engaging control (please refer to the setting of values U and Z of P5-88.)			
JOGU	ALL	-	When this DI is ON, the motor JOG operates in forward direction.			
JOGD	ALL	-	When this DI is ON, the motor JOG operates in reverse direction.			
EV1	PR	-	Event trigger PR command			
EV2	PR	-	Event trigger PR command			
EV3	PR	-	Event trigger PR command			
EV4	PR	-	Event trigger PR command			
GNUM0	PT, PR, PT-S, PR-S	-	Electronic gear ratio (numerator) selection 0 (Please refer to P2-60 ~ P2-62 for gear ratio selection (numerator).)			

DI Signal Name	Operation Mode	Pin No.	Function	Wiring Method (Refer to section 3.4.3)
GNUM1	PT, PR, PT-S, PR-S	-	Electronic gear ratio (numerator) selection 1 (Please refer to P2-60 ~ P2-62 for gear ratio selection (numerator).)	
INHP	PT, PT-S	-	Pulse input is prohibited. In position mode, when this DI is ON, the external pulse input command is not working.	

The default setting of DI and DO in each operation mode is shown as the followings. Please note that the following tables neither detail the information as the previous one nor show the Pin number of each signal. However, each operation mode is separated in different columns in order to avoid the confusion.

Table 3.1 Default Value of DI Input Function

Symbol	DI Code	Input Function	PT	PR	S	T	Sz	Tz	PT-S	PT-T	PR-S	PR-T	S-T
SON	0x01	Servo On	DI1	DI1	DI1	DI1	DI1	DI1	DI1	DI1	DI1	DI1	DI1
ARST	0x02	Alarm Reset	DI5	DI5	DI5	DI5	DI5	DI5					
GAINUP	0x03	Gain switch											
CCLR	0x04	Pulse clear	DI2						DI2	DI2			
ZCLAMP	0x05	Zero speed CLAMP											
CMDINV	0x06	The input command will be in reverse direction.											
Reserved	0x07	Reserved											
CTRG	0x08	Internal position command triggered		DI2							DI2	DI2	
TRQLM	0x09	Torque limit			DI2		DI2						
SPDLM	0x10	Speed limit				DI2		DI2					
POS0	0x11	Internal position command selection 0		DI3							DI3	DI3	
POS1	0x12	Internal position command selection 1		DI4							DI4	DI4	
POS2	0x13	Internal position command selection 2											
POS3	0x1A	Internal position command selection 3											
POS4	0x1B	Internal position command selection 4											
POS5	0x1C	Internal position command selection 5											

Symbol	DI Code	Input Function	PT	PR	S	T	Sz	Tz	PT-S	PT-T	PR-S	PR-T	S-T
STOP	0x46	Motor stops											
SPD0	0x14	Speed command selection 0			D13		D13		D13		D15		D13
SPD1	0x15	Speed command selection 1			D14		D14		D14		D16		D14
TCM0	0x16	Torque command selection 0	D13			D13		D13		D13		D15	D15
TCM1	0x17	Torque command selection 1	D14			D14		D14		D14		D16	D16
S-P	0x18	Mode switch between speed and position command							D17		D17		
S-T	0x19	Mode switch between speed and torque command											D17
T-P	0x20	Mode switch between torque and position command								D17		D17	
PT-PR	0x2B	Switch between PT and PR command											
EMGS	0x21	Emergency stop	D18	D18	D18	D18	D18	D18	D18	D18	D18	D18	D18
NL(CWL)	0x22	Reverse inhibit limit	D16	D16	D16	D16	D16	D16					
PL(CCWL)	0x23	Forward inhibit limit	D17	D17	D17	D17	D17	D17					
ORGP	0x24	Original point of homing											
SHOM	0x27	Homing is activated											
CAM	0x36	E-Cam engaged											
JOGU	0x37	Forward JOG input											
JOGD	0x38	Reverse JOG input											
EV1	0x39	Event trigger PR command #1(refer to the setting of P5-98, P5-99)											
EV2	0x3A	Event trigger PR command #2 (refer to the setting of P5-98, P5-99)											
EV3	0x3B	Event trigger PR command #3 firmware V1.008 sub04 will be provided afterwards)											
EV4	0x3C	Event trigger PR command #4 (firmware											

Symbol	DI Code	Input Function	PT	PR	S	T	Sz	Tz	PT-S	PT-T	PR-S	PR-T	S-T
		V1.008 sub04 will be provided afterwards)											
GNUM0	0x43	Electronic gear ratio (numerator) selection 0											
GNUM1	0x44	Electronic gear ratio (numerator) selection 1											
INHP	0x45	Pulse input inhibit											

Note: refer to section 3.4.1 for corresponding pins of DI1 ~ 8.

Table 3.2 Default Value of DO Output Function

Symbol	DO Code	Output Function	PT	PR	S	T	Sz	Tz	PT-S	PT-T	PR-S	PR-T	S-T
SRDY	0x01	Servo is ready	DO1	DO1	DO1	DO1	DO1	DO1	DO1	DO1	DO1	DO1	DO1
SON	0x02	Servo is On											
ZSPD	0x03	Zero-speed reached	DO2	DO2	DO2	DO2	DO2	DO2	DO2	DO2	DO2	DO2	DO2
TSPD	0x04	Reach the target speed			DO3	DO3	DO3	DO3	DO3	DO3	DO3	DO3	DO3
TPOS	0x05	Reach the target position	DO4	DO4					DO4	DO4	DO4	DO4	
TQL	0x06	Torque limit											
ALRM	0x07	Servo alarm	DO5	DO5	DO5	DO5	DO5	DO5	DO5	DO5	DO5	DO5	DO5
BRKR	0x08	Brake			DO4	DO4	DO4	DO4					
HOME	0x09	Homing complete	DO3	DO3									
OLW	0x10	Early warning for overload											
WARN	0x11	Servo warning											
OVF	0x12	Position command / feedback overflows											
SNL (SCWL)	0x13	Reverse software limit											
SPL (SCCWL)	0x14	Forward software limit											
Cmd_OK	0x15	Internal position command is completed											
CAP_OK	0x16	Capture procedure is completed											
MC_OK	0x17	Servo procedure is completed											

Symbol	DO Code	Output Function	PT	PR	S	T	Sz	Tz	PT-S	PT-T	PR-S	PR-T	S-T
CAM_AREA	0x18	Master position area of E-CAM											
SP_OK	0x19	Target speed reached											
SDO_0	0x30	Output the status of bit00 of P4-06											
SDO_1	0x31	Output the status of bit01 of P4-06											
SDO_2	0x32	Output the status of bit02 of P4-06											
SDO_3	0x33	Output the status of bit03 of P4-06											
SDO_4	0x34	Output the status of bit04 of P4-06											
SDO_5	0x35	Output the status of bit05 of P4-06											
SDO_6	0x36	Output the status of bit06 of P4-06											
SDO_7	0x37	Output the status of bit07 of P4-06											
SDO_8	0x38	Output the status of bit08 of P4-06											
SDO_9	0x39	Output the status of bit09 of P4-06											
SDO_A	0x3A	Output the status of bit10 of P4-06											
SDO_B	0x3B	Output the status of bit11 of P4-06											
SDO_C	0x3C	Output the status of bit12 of P4-06											
SDO_D	0x3D	Output the status of bit13 of P4-06											
SDO_E	0x3E	Output the status of bit14 of P4-06											
SDO_F	0x3F	Output the status of bit15 of P4-06											

Note: refer to section 3.4.1 for corresponding pins of DO1 ~ 5.

3.4.3 Wiring Diagrams (CN1)

The valid voltage of speed analog command and torque analog command is between -10V and +10V. The command value can be set via relevant parameters. The input impedance is 10 kΩ.

C1: Speed, Input of Torque Analog Command

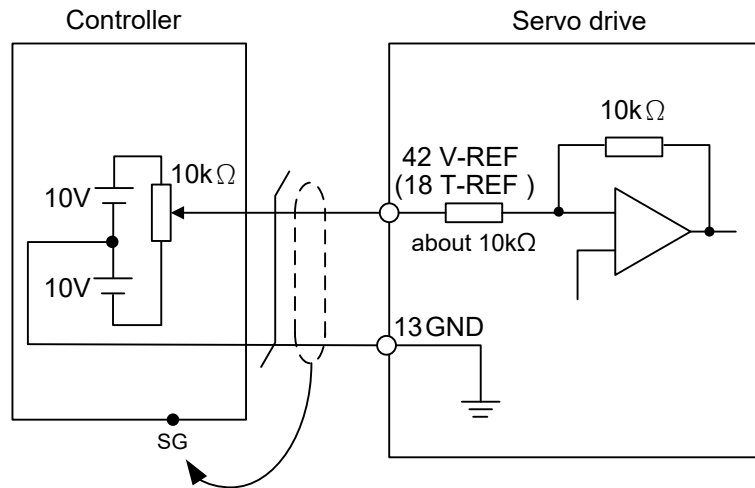

C2: Analog Monitor Output MON1, MON2

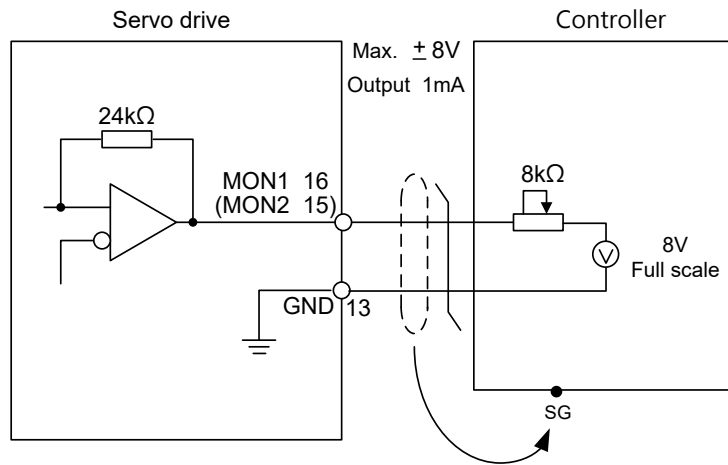

Pulse command can be input by the way of open-collector or Line driver. The maximum input pulse of Line driver is 500 kpps and 200 kpps for open-collector.

C3-1: The source of pulse input is open-collector NPN equipment which applies the internal power of the servo drive.

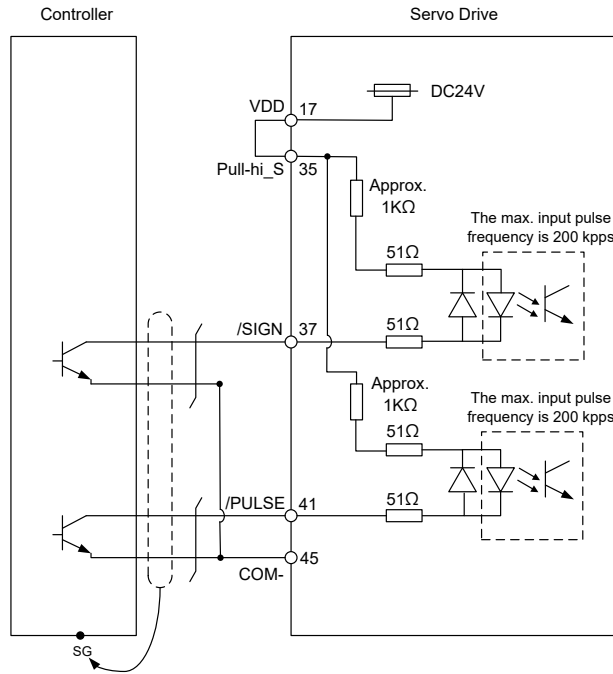

C3-2: The source of pulse input is open-collector PNP equipment which applies the internal power of the servo drive.

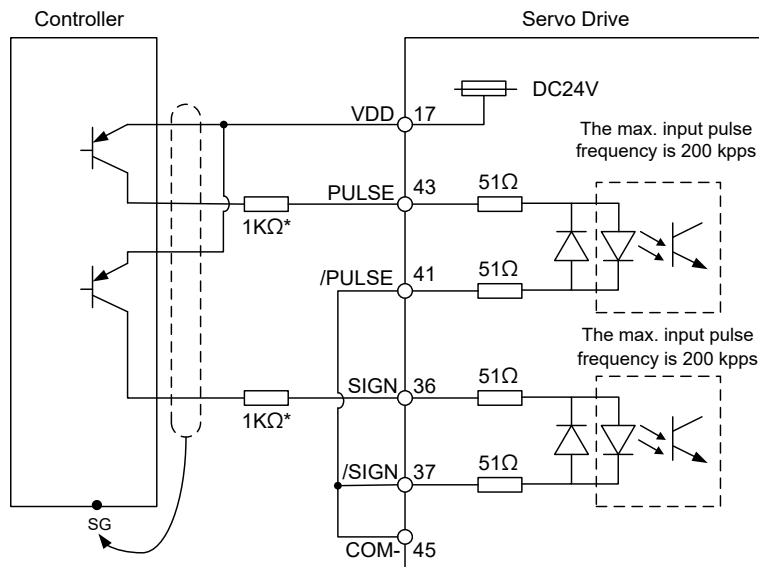

Note: Resistor of 1 kΩ (1 w) has to be connected.



➤ **Caution: Do not apply to dual power or it may damage the servo drive.**

C3-3: The source of pulse input is open-collector NPN equipment and applies the external power.

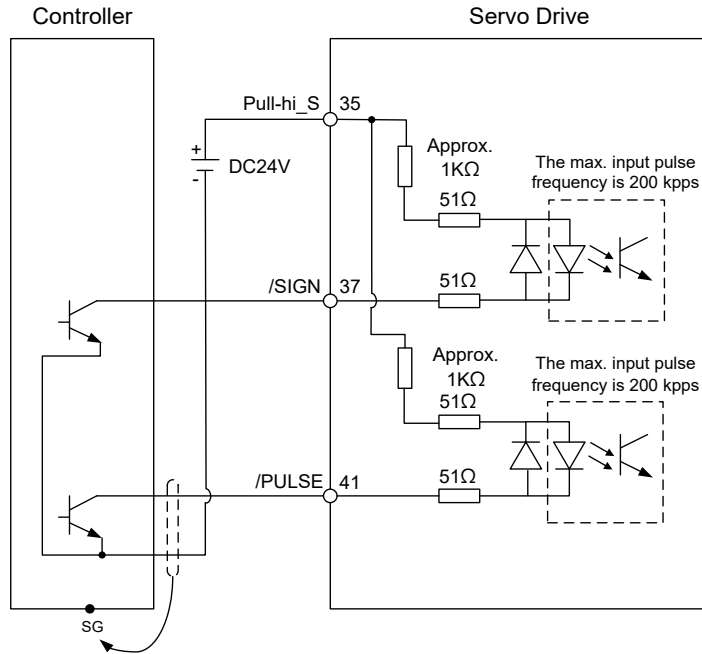

➤ **Caution: Do not apply to dual power or it may damage the servo drive.**

C3-4: The source of pulse input is open-collector PNP equipment and applies the external power.

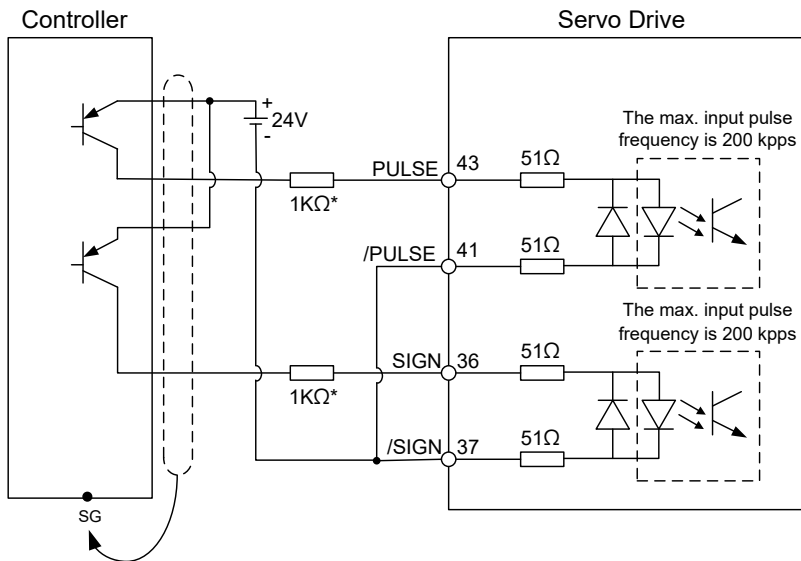

Note: Resistor of 1 kΩ (1 w) has to be connected.

C4-1: Pulse input (Line driver) can only apply to 5V power. Do not apply to 24V power.

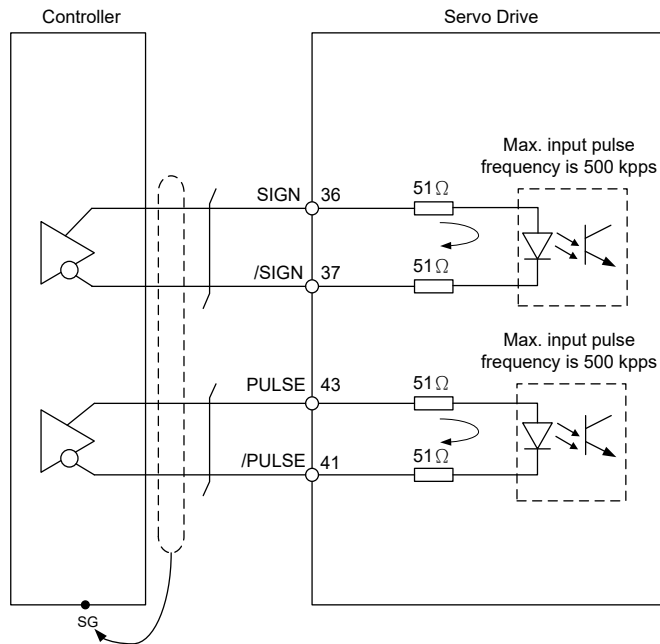

➤ ***This opto-isolator is one-way input. Please be ensured the direction of current of pulse input is correct.***

C4-2: High-speed pulse input (Line driver) can only apply to 5V power. Do not apply to 24V power.

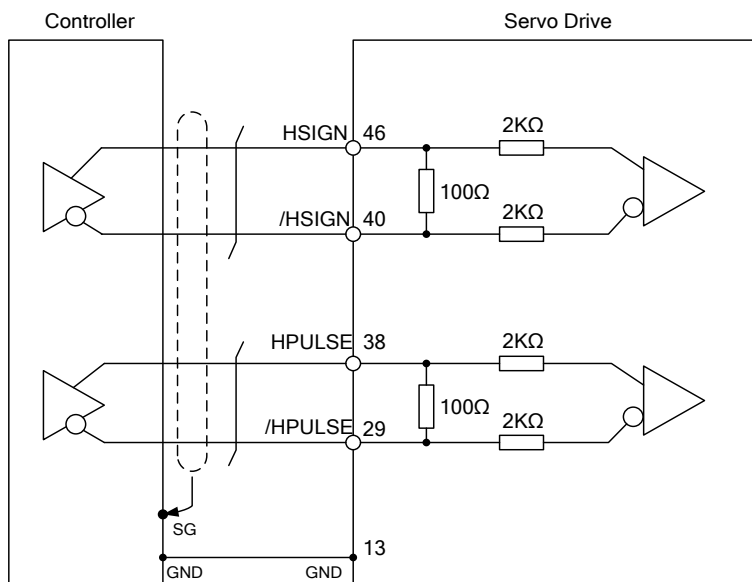

➤ ***The high-speed pulse input interface of the servo drive is not the isolated interface. In order to reduce the interference of the noise, it is suggested that the terminal ground of the controller and the servo drive should be connected to each other.***

When the drive connects to inductive load, the diode has to be installed. (The permissible current is under 40 mA. The surge current is under 100 mA; the maximum voltage is 30V.)

C5: Wiring of DO signal. The servo drive applies to the internal power and the resistor is general load.

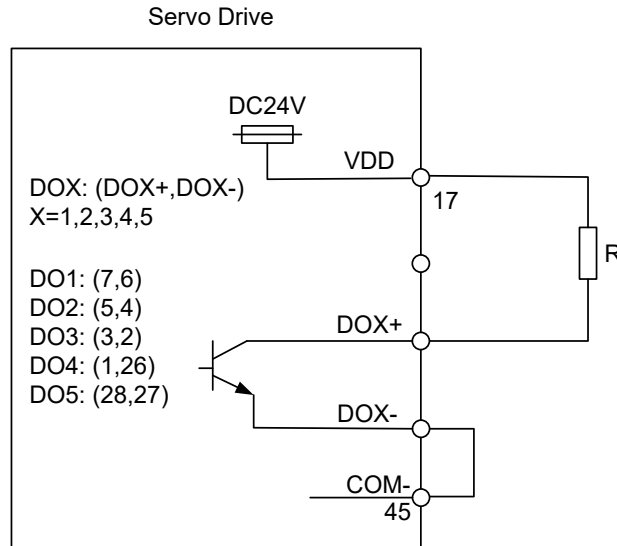

C6: Wiring of DO signal. The servo drive applies to the internal power and the resistor is inductive load.

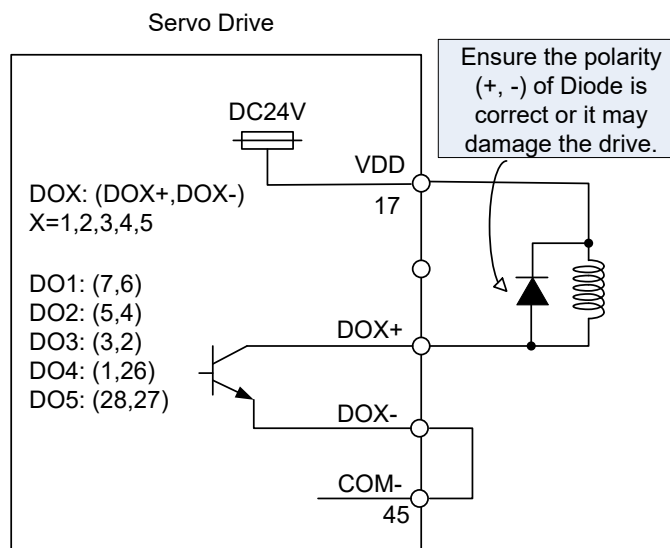

C7: Wiring of DO signal. The servo drive applies to the external power and the resistor is general load.

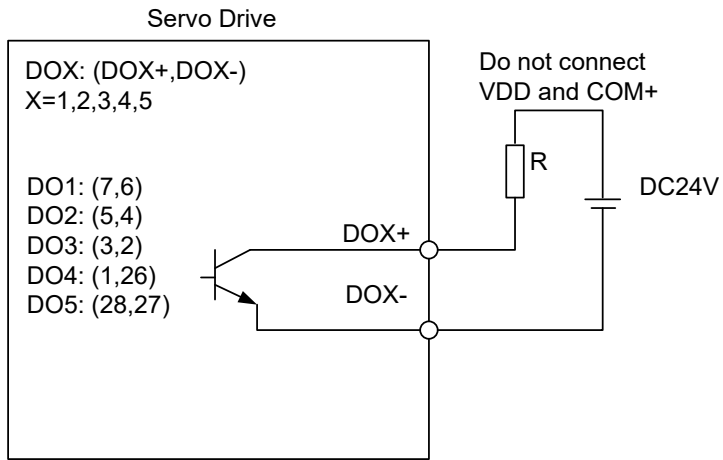

C8: Wiring of DO signal. The servo drive applies to the external power and the resistor is inductive load.

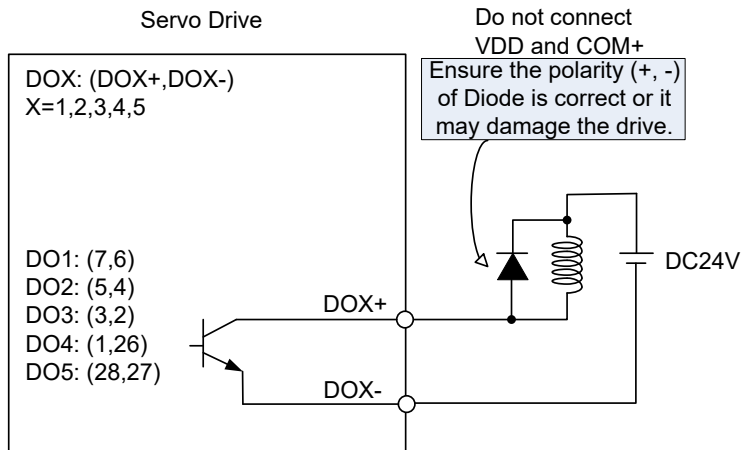

DI wiring — Input signals by relay or open-collector transistor.

Conditions of DI On/Off:

ON: 15V – 24V; condition: input current = 3 mA.

OFF: 5V or below; input current must not be higher than 0.5 mA.

NPN transistor, common emitter (E) mode (**SINK** mode)

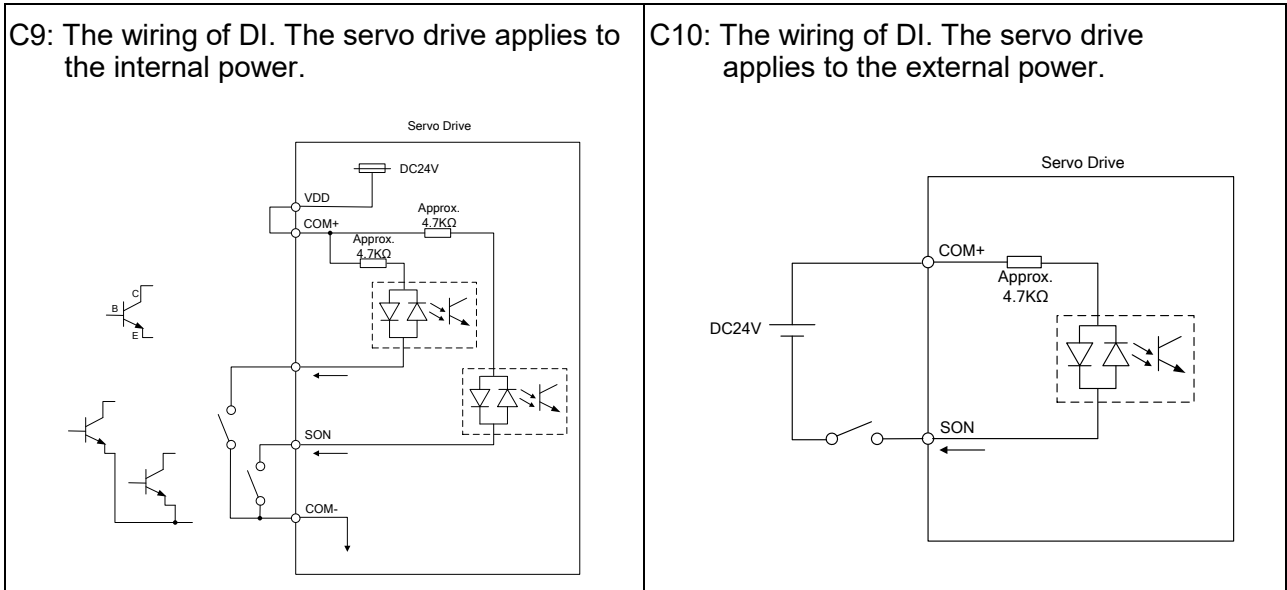

PNP transistor, common emitter (E) mode (**SOURCE** mode)

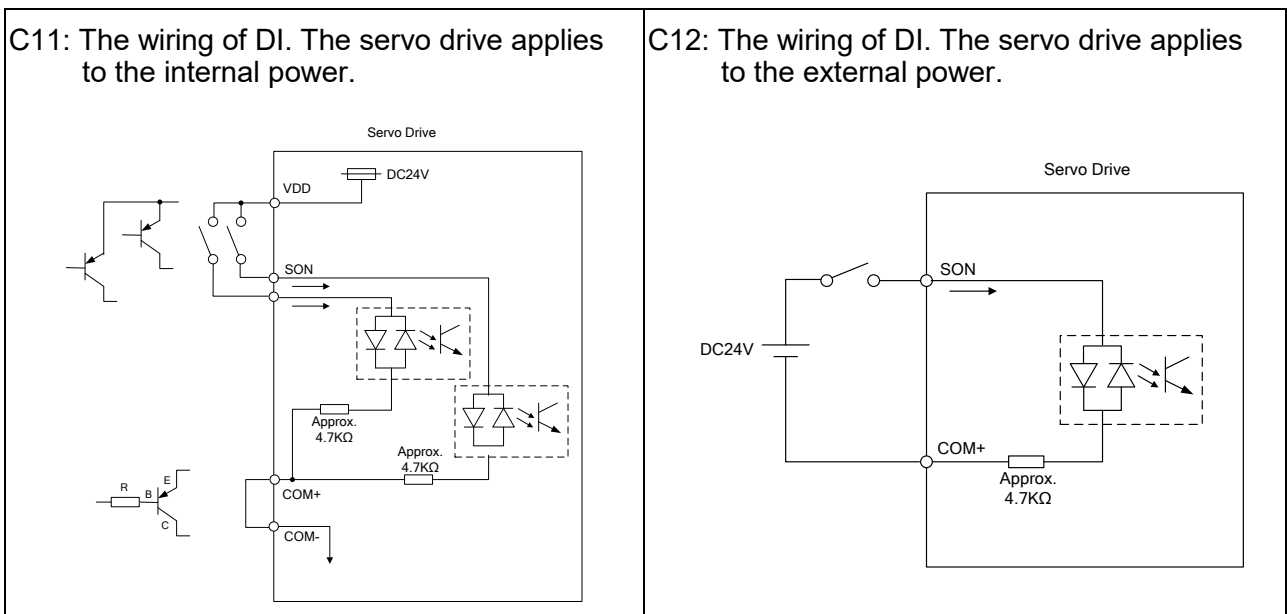

➤ **Caution:** Do not apply to dual power or it may damage the servo drive.

C13: Encoder signal output (Line driver)

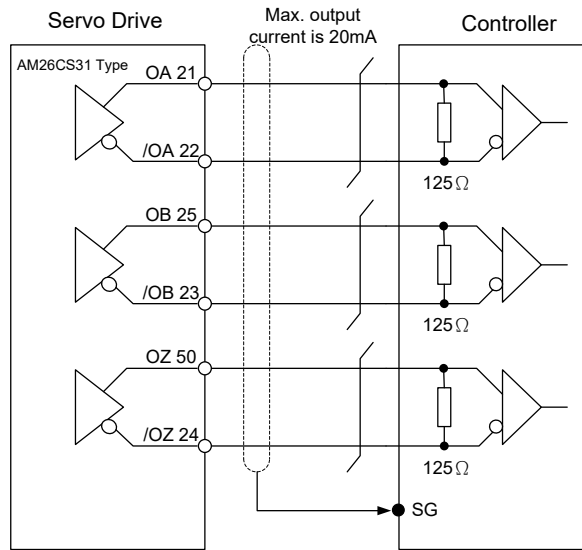

C14: Encoder signal output (Opto-isolator)

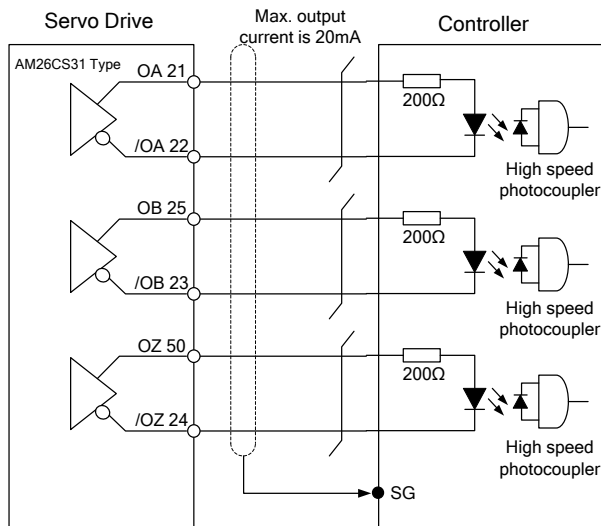

C15: Encoder OCZ output (open-collector Z pulse output)

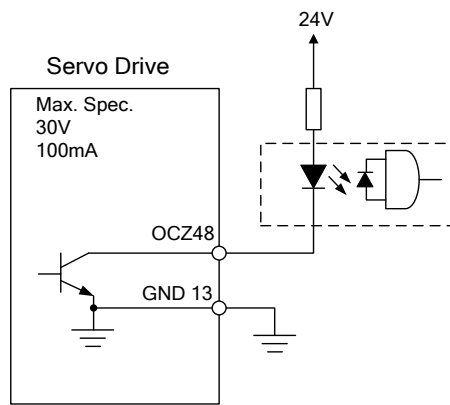

3.4.4 DI and DO Signal Specified by Users

If the default setting of DI/DO signal cannot satisfy the need, self-set the DI/DO signal will do and be easy. The signal function of DI1 ~ 8, DI9 ~ DI13, and DO1 ~ 5 is determined by parameters P2-10 ~ P2-17 and parameters P2-18 ~ P2-22 respectively. Please refer to section 8.2, which is shown as the following tables. Enter the DI or DO code in the corresponding parameter to set the DI/DO function.

Signal Name		Pin No.	Corresponding Parameter
Standard DI	DI1-	CN1-9	P2-10
	DI2-	CN1-10	P2-11
	DI3-	CN1-34	P2-12
	DI4-	CN1-8	P2-13
	DI5-	CN1-33	P2-14
	DI6-	CN1-32	P2-15
	DI7-	CN1-31	P2-16
	DI8-	CN1-30	P2-17
Extension DI (optional)	EDI9	CN7-2	P2-36
	EDI10	CN7-3	P2-37
	EDI11	CN7-4	P2-38
	EDI12	CN7-5	P2-39
	EDI13	CN7-6	P2-40
	EDI14	CN7-7	P2-41

Signal Name		Pin No.	Corresponding Parameter
Standard DO	DO1+	CN1-7	P2-18
	DO1-	CN1-6	
	DO2+	CN1-5	P2-19
	DO2-	CN1-4	
	DO3+	CN1-3	P2-20
	DO3-	CN1-2	
	DO4+	CN1-1	P2-21
	DO4-	CN1-26	
	DO5+	CN1-28	P2-22
	DO5-	CN1-27	

3.4.5 Application: Using CN1 Quick Connector for Wiring

The CN1 quick connector (ASD-IF-SC5020) is designed for easy wiring. It is applicable to ASDA-A2 and ASDA-A2R series servo drive and can satisfy the demand of different DI/O application. It will be a good choice for those who do not want to solder the wires by themselves. The spring terminal blocks prevent vibration from loosening the wires. It is rather convenient and fast when wiring. 5 digital inputs, 4 digital outputs, pulse command inputs, and Z phase open-collector outputs are included.

Pin definition is as the following:

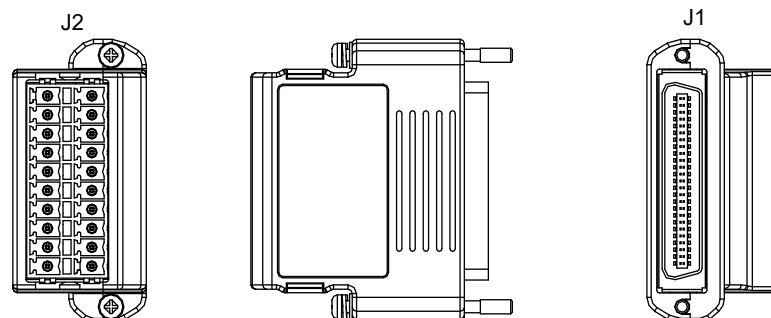

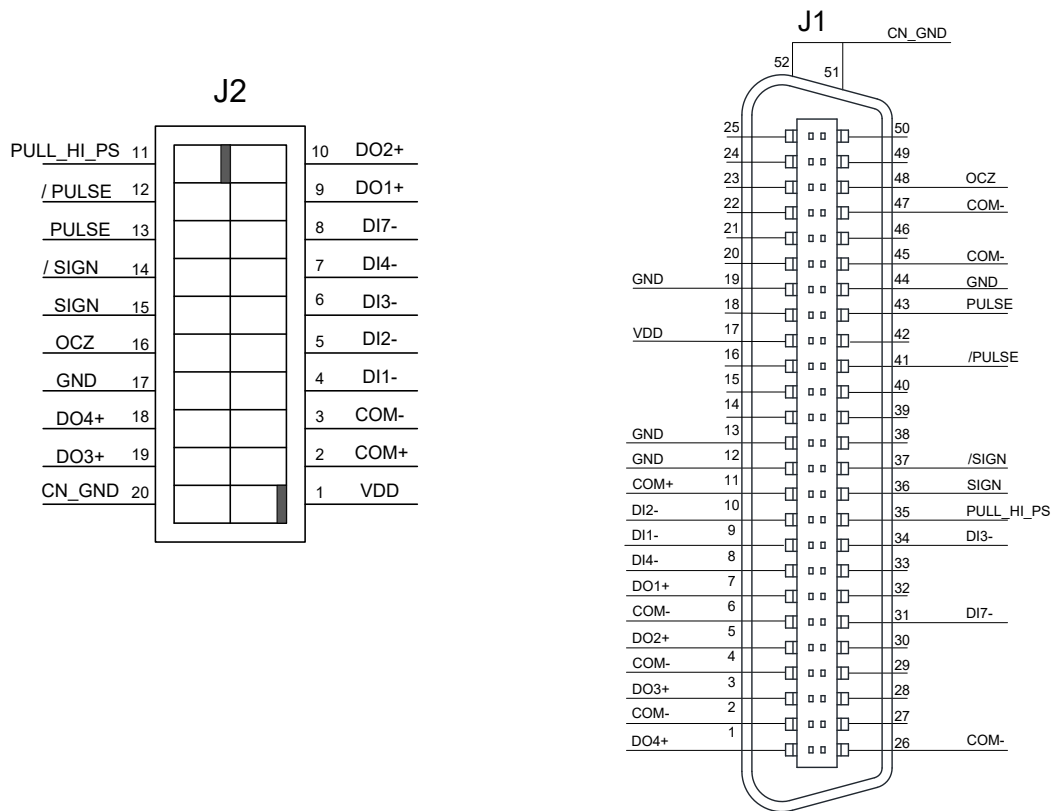

J2		J1	
PIN	Description	PIN	Description
1	VDD	17	VDD
2	COM+	11	COM+
3	COM-	2, 4, 6, 26, 45, 47	COM-
4	DI1-	9	DI1-
5	DI2-	10	DI2-
6	DI3-	34	DI3-
7	DI4-	8	DI4-
8	DI7-	31	DI7-
9	DO1+	7	DO1+
10	DO2+	5	DO2+
11	PULL_HI_PS	35	PULL_HI_PS
12	/PULSE	41	/PULSE
13	PULSE	43	PULSE
14	/SIGN	37	/SIGN
15	SIGN	36	SIGN
16	OCZ	48	OCZ
17	GND	12, 13, 19, 44	GND
18	DO4+	1	DO4+
19	DO3+	3	DO3+
20	CN_GND	51, 52	CN_GND

Wiring example:

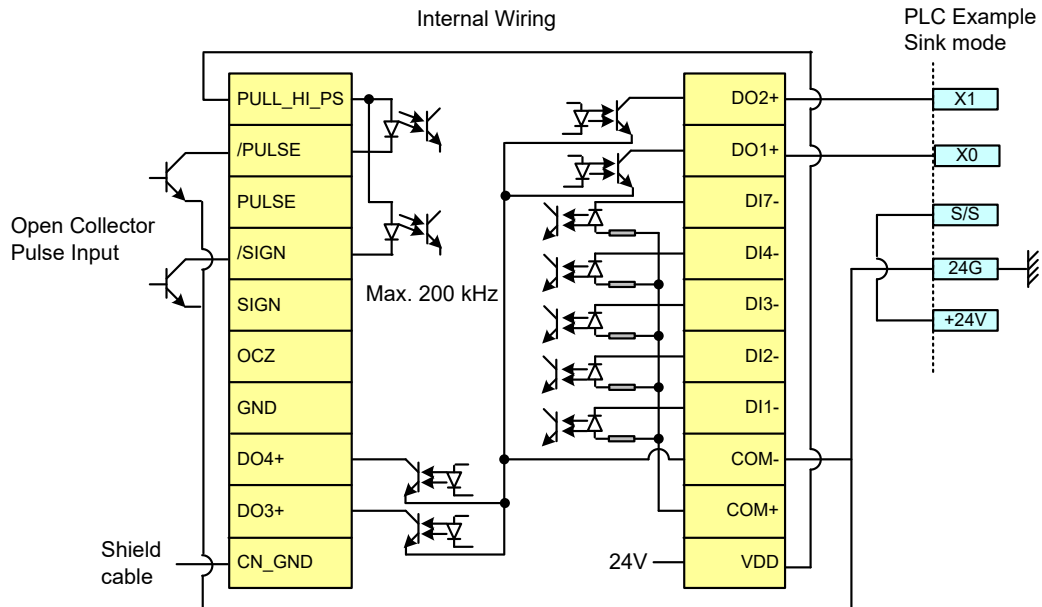
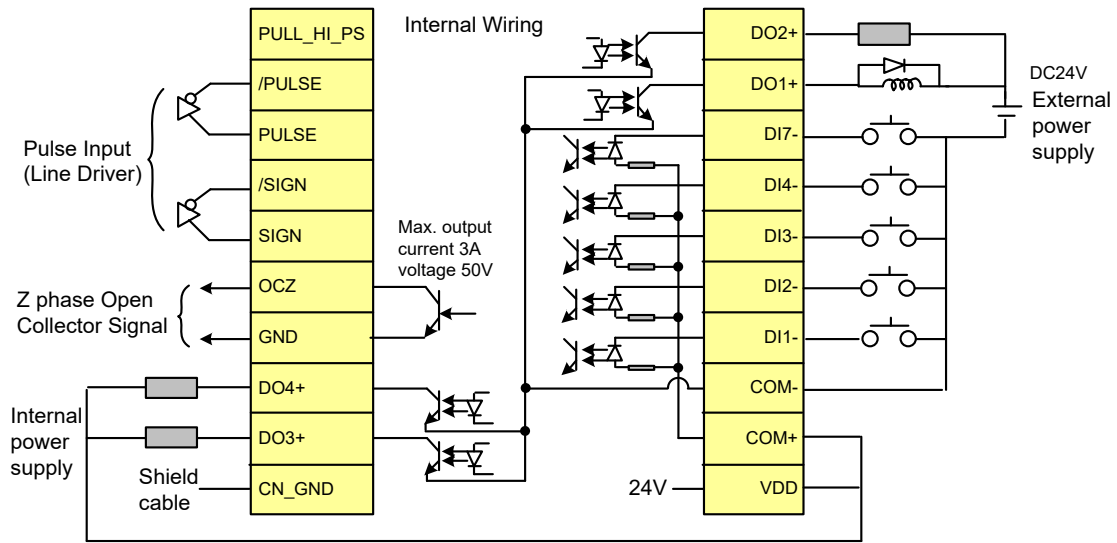

Wiring and installation of CN1 quick connector:

Installation

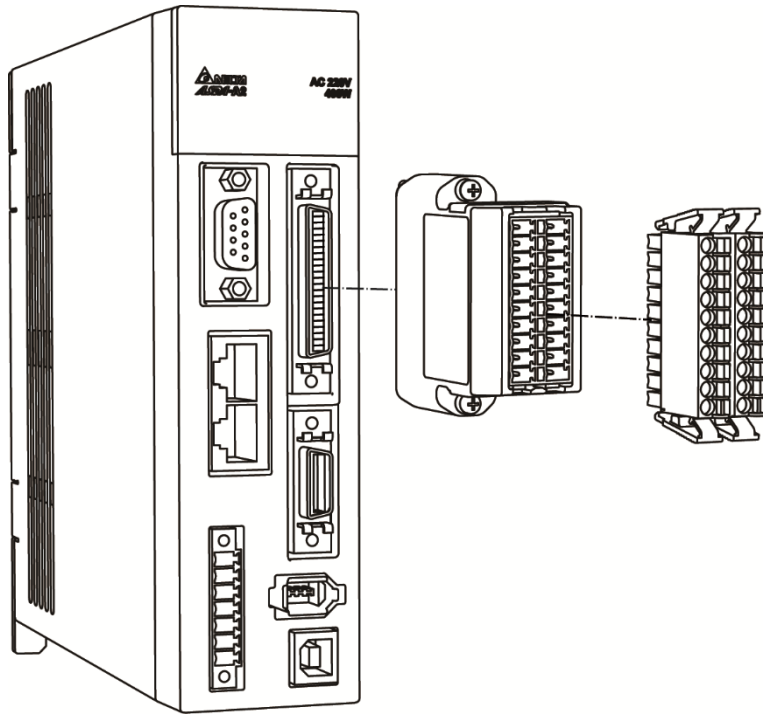

Wiring

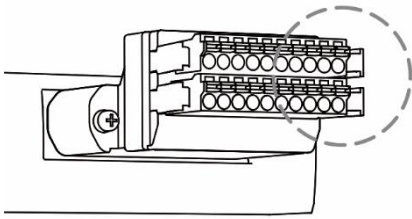

- (1) The CN1 quick connector has multiple spring terminals. Please determine which terminal is to be wired in advance.

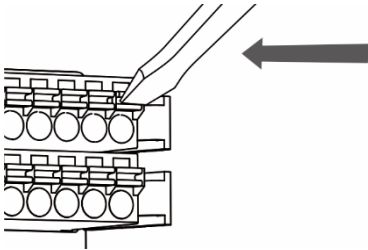

- (2) Use a flathead screwdriver to press the spring down to open the pin.

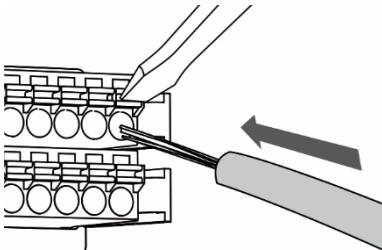

- (3) Insert the stripped wire into the pin.

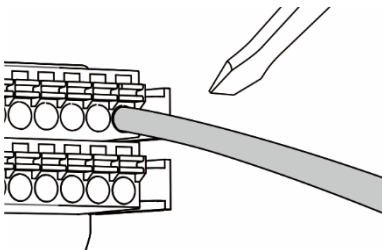

- (4) Withdraw the screwdriver to complete the wiring.

3.5 CN2 Connector

The terminal block of the connector and pin number are as follows:

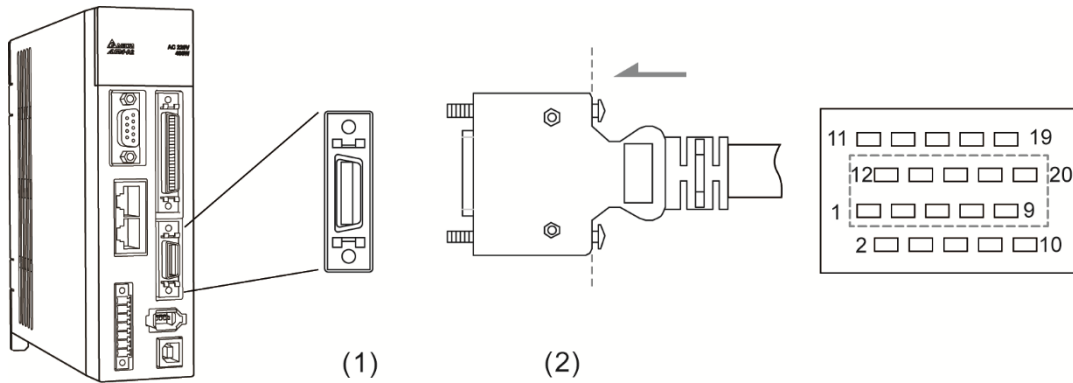

(1) CN2 connector (Female); (2) CN2 connector (Male)

CN2 connector ends:

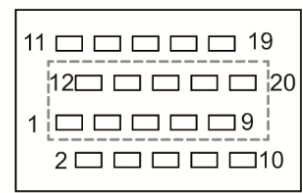
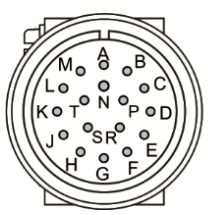
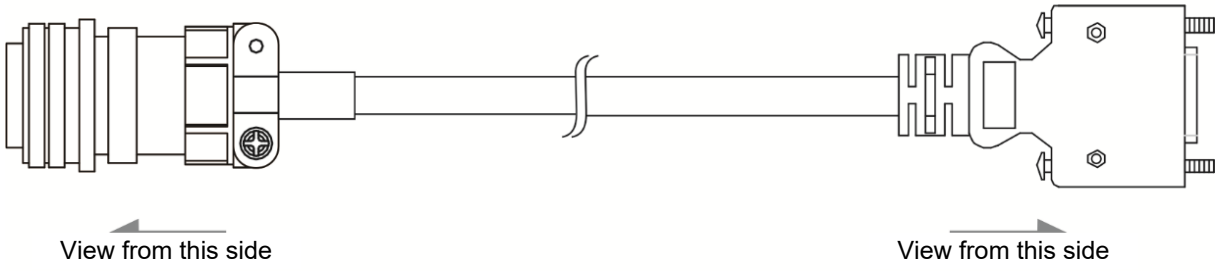
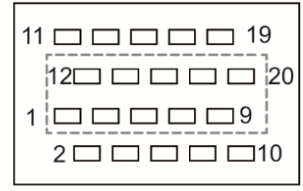
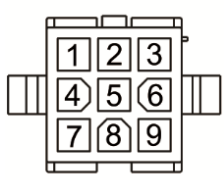
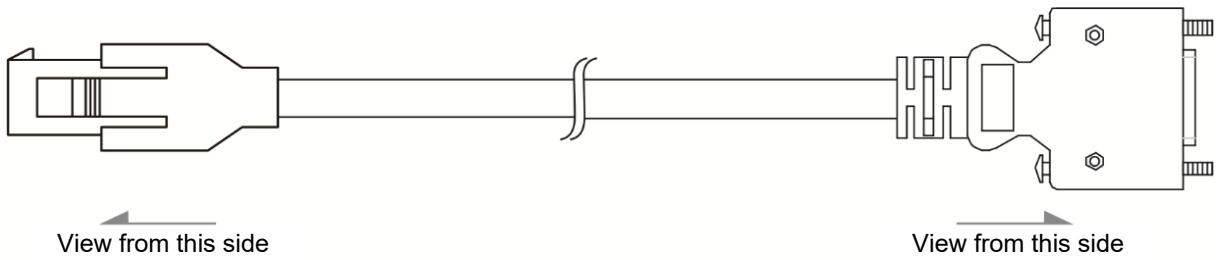

The definition of each signal is as follows:

Drive Connector			Encoder Connector		
Pin No.	Terminal Symbol	Function and Description	Military Connector	Quick Connector	Color
5	T+	Serial communication signal input / output (+)	A	1	Blue
4	T-	Serial communication signal input / output (-)	B	4	Blue & Black
14, 16	+5V	+5V power supply	S	7	Red / Red & White
13, 15	GND	Power ground	R	8	Black / Black & White
Shell	Shielding	Shielding	L	9	-
7	BAT+	Voltage of the battery is 3.6V (Applicable to encoder cable with battery box)	C	2	Green
9	BAT-	Ground cable of the battery (Applicable to encoder cable with battery box)	D	5	Black

About shielding and ground

The two sides of CN2 encoder cable are CN2 connector and encoder connector. Shielding and ground conductor should be correctly connected to the corresponding pins so as to effectively shield and ground.

The shielding procedures of CN2 encoder connector are as followings:

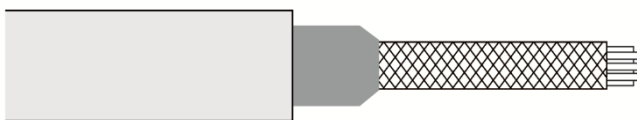

- (1) Cut through the cable and expose the core wire which covers the metal core wires with shielding. The reserved core wire length should be 20 - 30 mm (0.79 - 1.18 inches). Then, cover a 45 mm (1.77 inches) heat shrink tube on the cable.

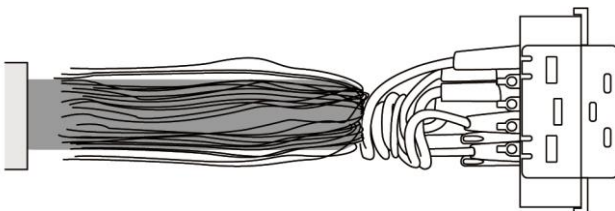

- (2) Spread the metal core wires with shielding and turn it upside down in downward direction. Ensure to follow the above table of CN2 Terminal Signal Identification to connect the pins one by one.

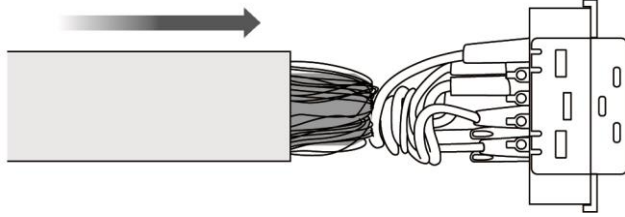

- (3) Leave a length of 5 - 10 mm (0.2 - 0.39 inches) metal core wires with shielding outside of the cable. The length is about the width of the metal saddle. The other unexposed wires of the cable should be protected by heat shrink tube for good ground contact.

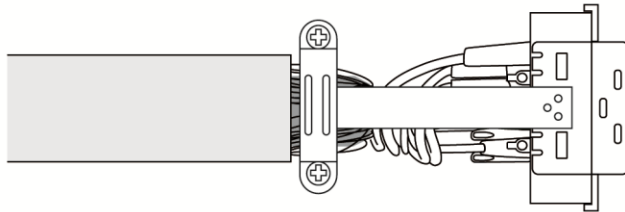

- (4) Install a metal saddle to fix the exposed metal core wires. The metal saddle must completely cover all the exposed metal core wires. The extended sheet metal should be connected to the metal part of the connector.

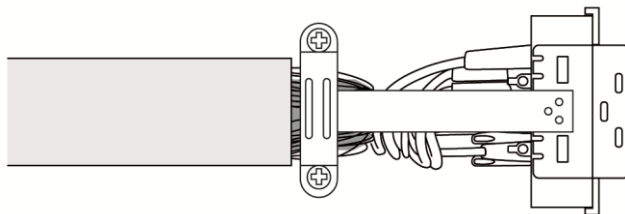

- (5) Install the connector with shielding into the plastic case as shown in the figure.

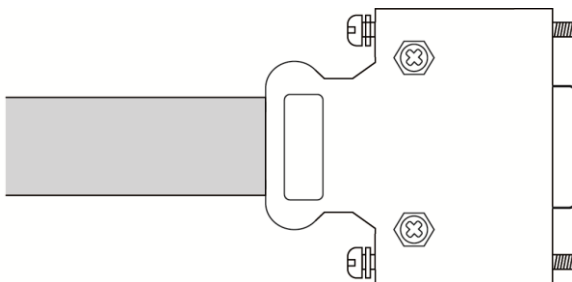

- (6) Tighten the screws to complete a shielded CN2 connector.

3.6 Wiring of CN3 Connector

3.6.1 Layout of CN3 Connector

The servo drive connects to the personal computer via communication connector. The user can operate the servo drive, PLC, or HMI through MODBUS using the assembly language. There are two commonly used communication interfaces, RS-232 and RS-485. Both can be set via parameter P3-05. RS-232 is more commonly used which communication distance is about 15 meter (49.21 feet). If the user selects RS-485, its transmission distance is longer and supports connecting more than one servo drives simultaneously.

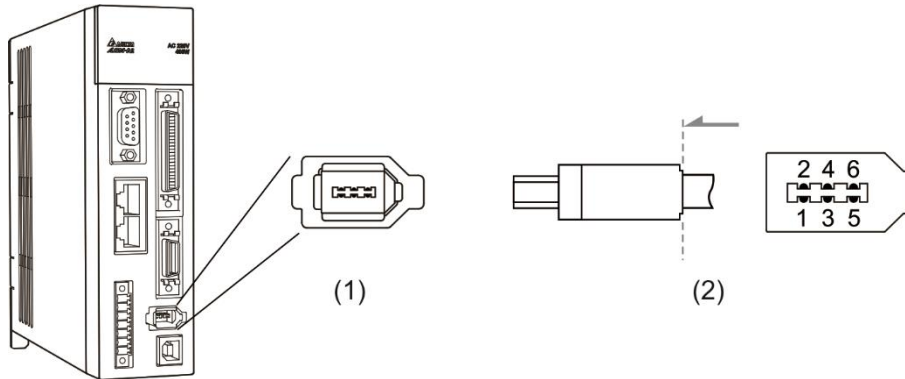

(1) CN3 connector (Female); (2) CN3 connector (Male)

Pin No.	Signal Name	Terminal Symbol	Function and Description
1	Grounding	GND	+5V connects to the signal terminal
2	RS-232 data transmission	RS-232_TX	The drive transmits the data The connector connects to RS-232 of PC
3	-	-	Reserved
4	RS-232 data receiving	RS-232_RX	The drive receives the data The connector connects to RS-232 of PC
5	RS-485 data transmission	RS-485(+)	The drive transmits the data to differential terminal (+)
6	RS-485 data transmission	RS-485(-)	The drive transmits the data to differential terminal (-)

Note:

1. Please refer to page 9-2 for the wiring of RS-485.
2. Two kinds of communication wire of IEEE1394 are commercially available. One of the internal ground terminals (Pin 1) will short-circuit the shielding and damage the drive. Do not connect GND to the shielding.

3.6.2 Connection between PC and Connector CN3

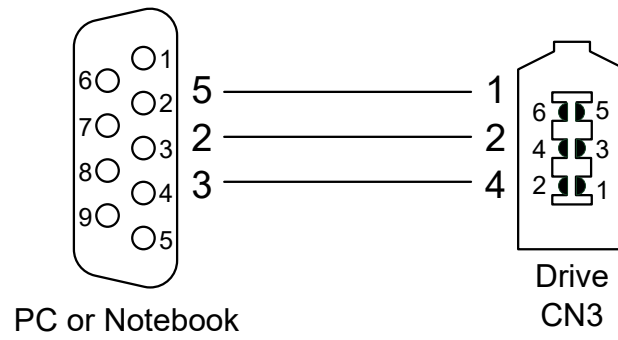

3.7 CN4 Serial Connector (USB)

CN4 is a serial connector which is used to connect PC software and increase the efficiency. The transmission speed of USB can be up to 1 MB, that is to say, PC Data Scope can obtain the correct data in real time.

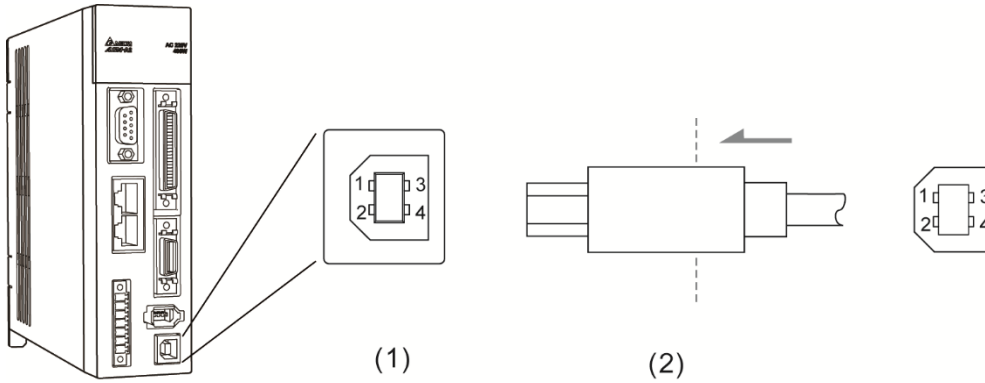

(1) CN4 connector (Female); (2) CN4 connector (Male)

Pin No.	Signal Name	Function and Description
1	V bus	DC +5V (external power supply)
2	D-	Data-
3	D+	Data+
4	GND	Ground

3.8 CN5 Connector (Full-closed loop)

Connect to the external linear scale or encoder (A, B, Z) and form a full-closed loop with the servo. In position mode, the pulse position command issued by the controller is based on the control loop of the external linear scale. Please refer to Chapter 6.

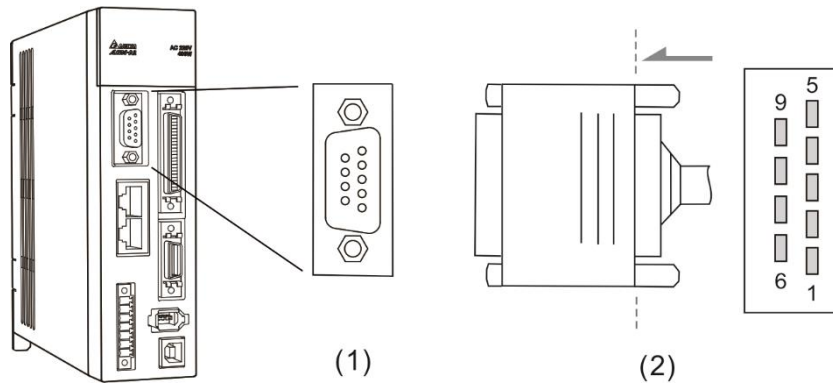

(1) CN5 connector (Female); (2) CN5 connector (Male)

Pin No.	Signal Name	Terminal Symbol	Function and Description
1	/Z phase input	Opt_/Z	Linear scale /Z phase output
2	/B phase input	Opt_/B	Linear scale /B phase output
3	B phase input	Opt_B	Linear scale B phase output
4	A phase input	Opt_A	Linear scale A phase output
5	/A phase input	Opt_/A	Linear scale /A phase output
6	Encoder grounding	GND	Ground
7	Encoder grounding	GND	Ground
8	Encoder power	+5V	Linear scale +5V power
9	Z phase input	Opt_Z	Linear scale Z phase output

Note:

1. It only supports AB phase signal and the encoder of 5V, 300 mA.
2. Application of full-closed loop: It supports the encoder with the highest resolution, 1280000 pulse/rev (Full-closed loop corresponds to the resolution of quadruple frequency when motor runs a cycle.).

3.9 CN6 Connector (CANopen)

3.9.1 CANopen communication

Based on the standard of CANopen DS301 and DS402, CN6 uses the standard CAN interface to implement position, torque, and speed mode. It also can read or monitor the drive status.

The station number of CANopen is the same as RS-232 / RS-485. All are set via parameter P3-00 and the transmission rate can be up to 1 Mbps. It provides two sets of communication ports for connecting multiple drives. Put the terminal resistor in the last servo drive.

Note: CANopen is supported by A2-M and A2-MN only.

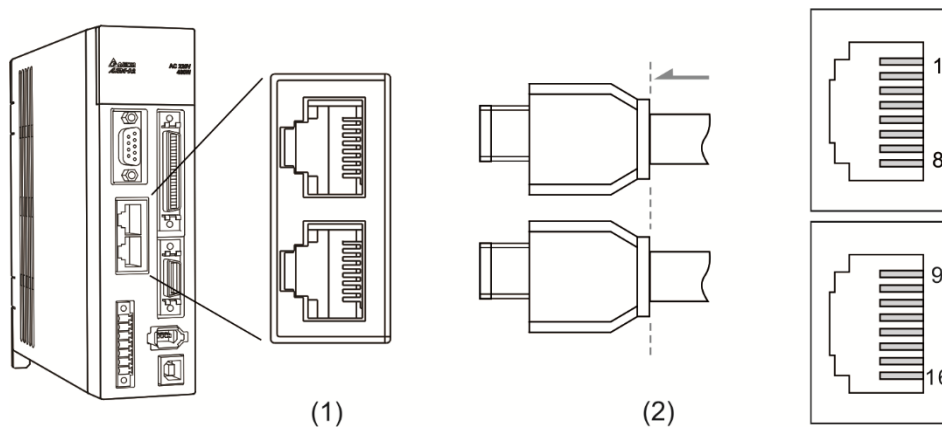

(1) CN6 connector (Female); (2) CN6 connector (Male)

Pin No.	Signal Name	Function and Description
1, 9	CAN_H	CAN_H bus line (dominant high)
2, 10	CAN_L	CAN_H bus line (dominant low)
3, 11	CAN_GND	Ground / 0V / V -
4, 12	-	Reserved
5, 13	-	Reserved
6, 14	-	Reserved
7, 15	CAN_GND	Ground / 0V / V -
8, 16	-	Reserved

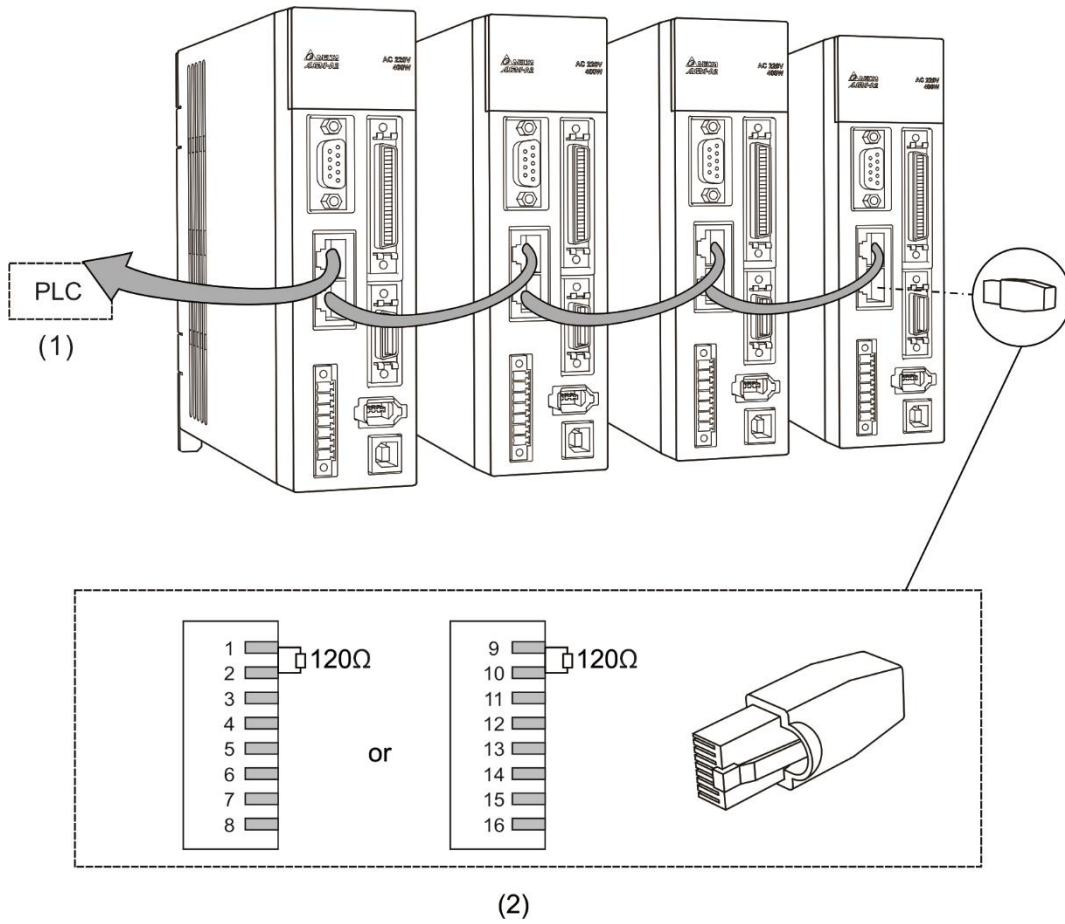

Note:

1. It is suggested to use a terminal resistor of 120Ω (Ohm) and 0.25 W or above.
2. The wiring method of concatenating more than one drives is based on two ports of CANopen. One is for receiving and another one is for transmission. Put the terminal resistor in the last servo drive.

3.9.2 DMCNET communication

The CN6 connector is a standard RJ45 connector with shielded cable. You can use it to connect to the host controller or motion control card. With Delta's DMCNET system, you can control position, torque, and speed, and access or monitor the servo status.

You can set the station number of DMCNET, as well as RS-232 / RS-485, with P3-00. Its maximum transmission rate is 20 Mbps. Two ports are provided for connecting multiple servo drives, with one way in and the other way out. Please put the terminal resistor (120Ω) in both ends of the equipment.

Note: DMCNET is supported by A2-F and A2-FN only.

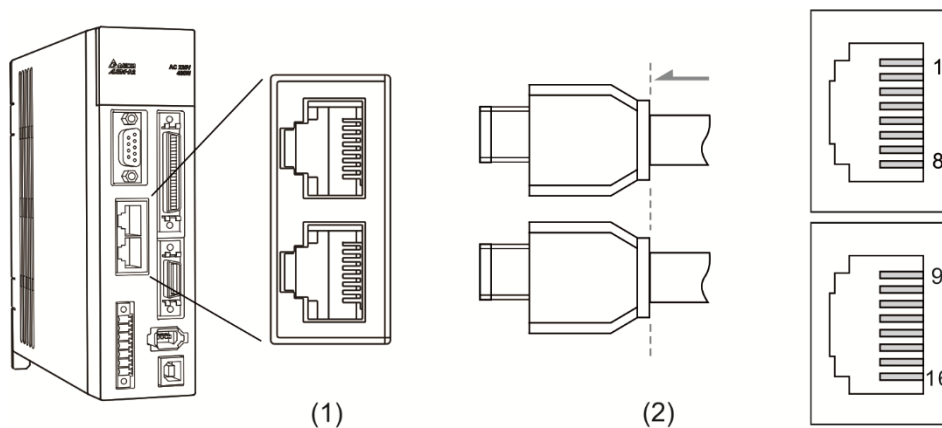

(1) CN6 connector (Female); (2) CN6 connector (Male)

Pin No.	Signal Name	Function and Description
1, 9	DMCNET_1A	DMCNET Channel 1 bus line (+)
2, 10	DMCNET_1B	DMCNET Channel 1 bus line (-)
3, 11	DMCNET_2A	DMCNET Channel 2 bus line (+)
4, 12 5, 13	-	Reserved
6, 14	DMCNET_2B	DMCNET Channel 2 bus line (-)
7, 15 8, 16	-	Reserved

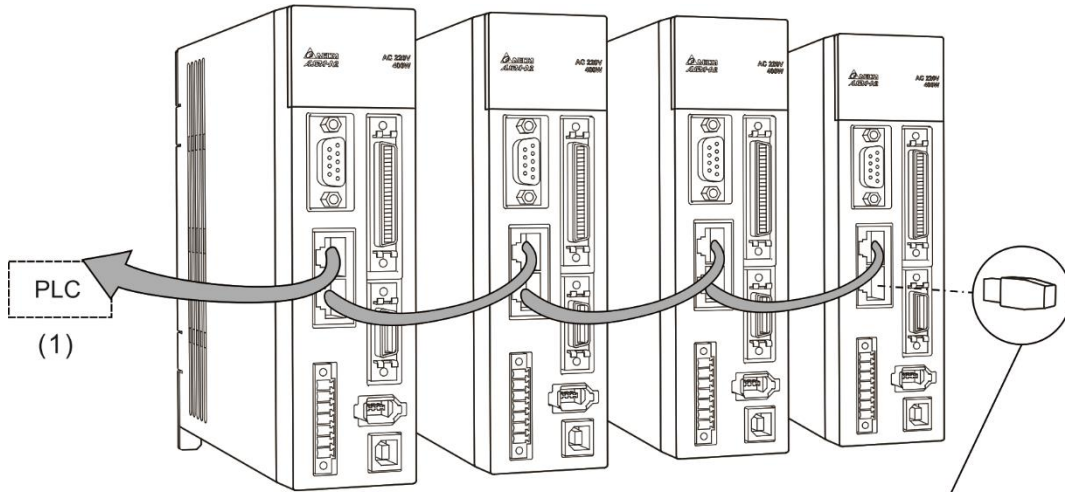

(1)

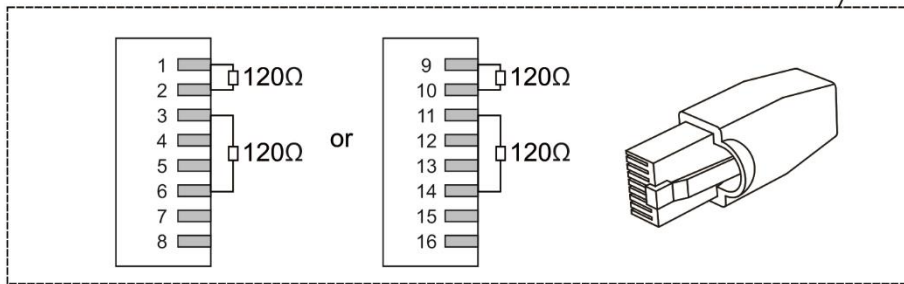

(2)

3.10 Expansion Digital Input Connector of CN7

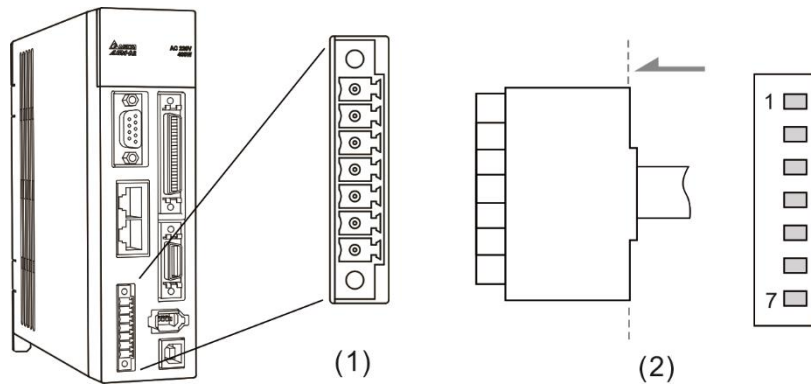

(1) CN7 connector (Female); (2) CN7 connector (Male)

The A2 series servo drive provides single-axis point-to-point controls with up to 64 points. When using the external DI to perform point-to-point motion controls and the internal DI (8 sets) are all occupied, you can use this optional expansion DI (6 sets) to meet the requirements. You must use the internal DI (8 sets) and the expansion DI (6 sets) to select the positioning point.

Pin No.	Signal Name	Terminal Symbol	Function Description
*1	VDD 24V power	COM+	VDD (24V) power supply, same as Pin 11 of CN1
2	Extension DI9	EDI 9-	Digital input DI9-
3	Extension DI10	EDI 10-	Digital input DI10-
4	Extension DI11	EDI 11-	Digital input DI11-
5	Extension DI12	EDI 12-	Digital input DI12-
6	Extension DI13	EDI 13-	Digital input DI13-
7	Extension DI14	EDI 14-	Digital input DI14-



➤ ***1 Caution: Do not use dual power supply or it might damage the servo drive.**

3.11 CN8 Connector of Battery Box

CN8 connector on servo drive is the power supply for absolute battery box. Please refer to Chapter 12 for further information.

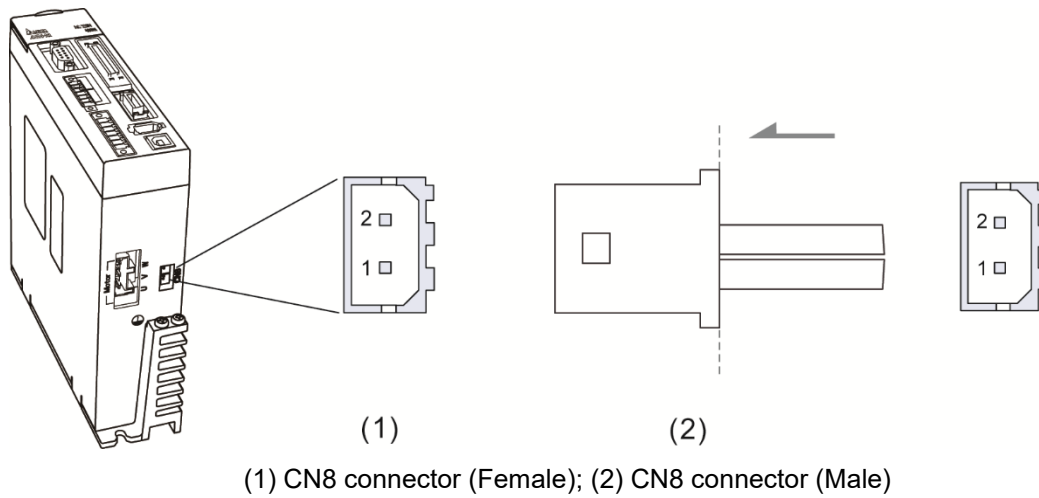

Pin definition:

Pin No.	Connector1	Connector2
1	BAT+	BAT+
2	BAT-	BAT-

Note: Due to the different design of servo drive model, CN8 might have one or two connectors, which however has the same pin definition.

3.12 Standard Connection Example – 220V series

3.12.1 Position (PT) Control Mode

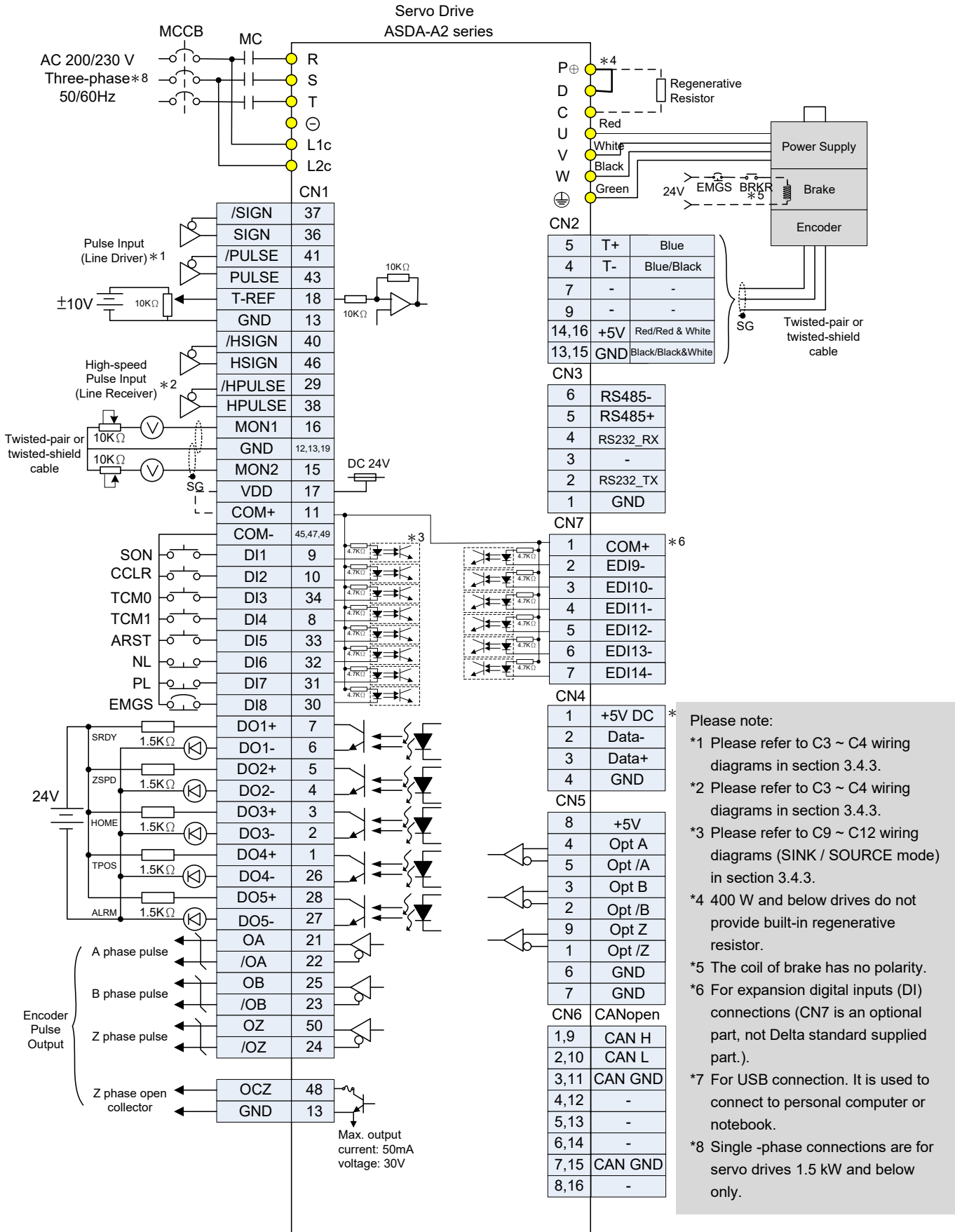

3.12.2 Position (PR) Control Mode

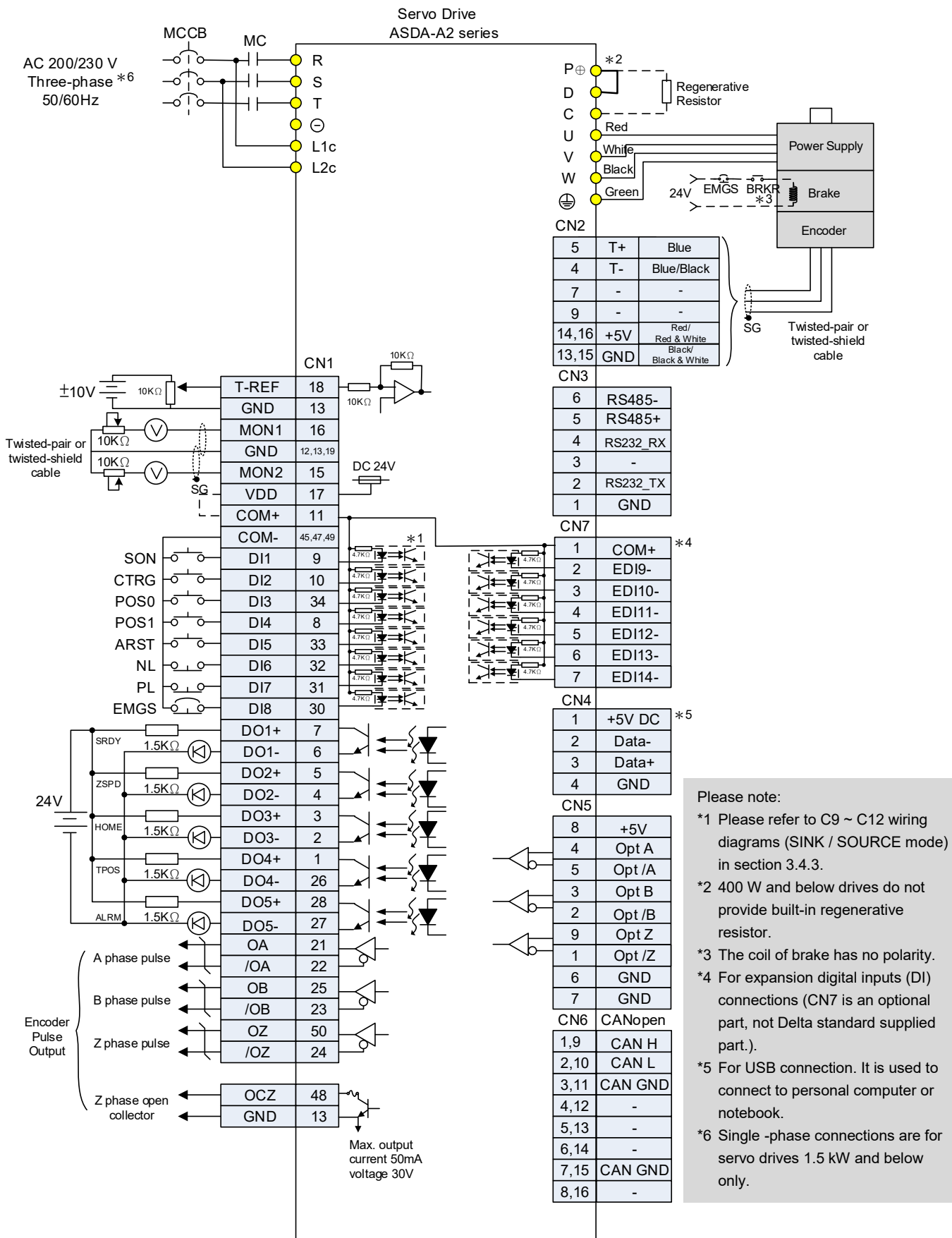

3.12.3 Speed Control Mode

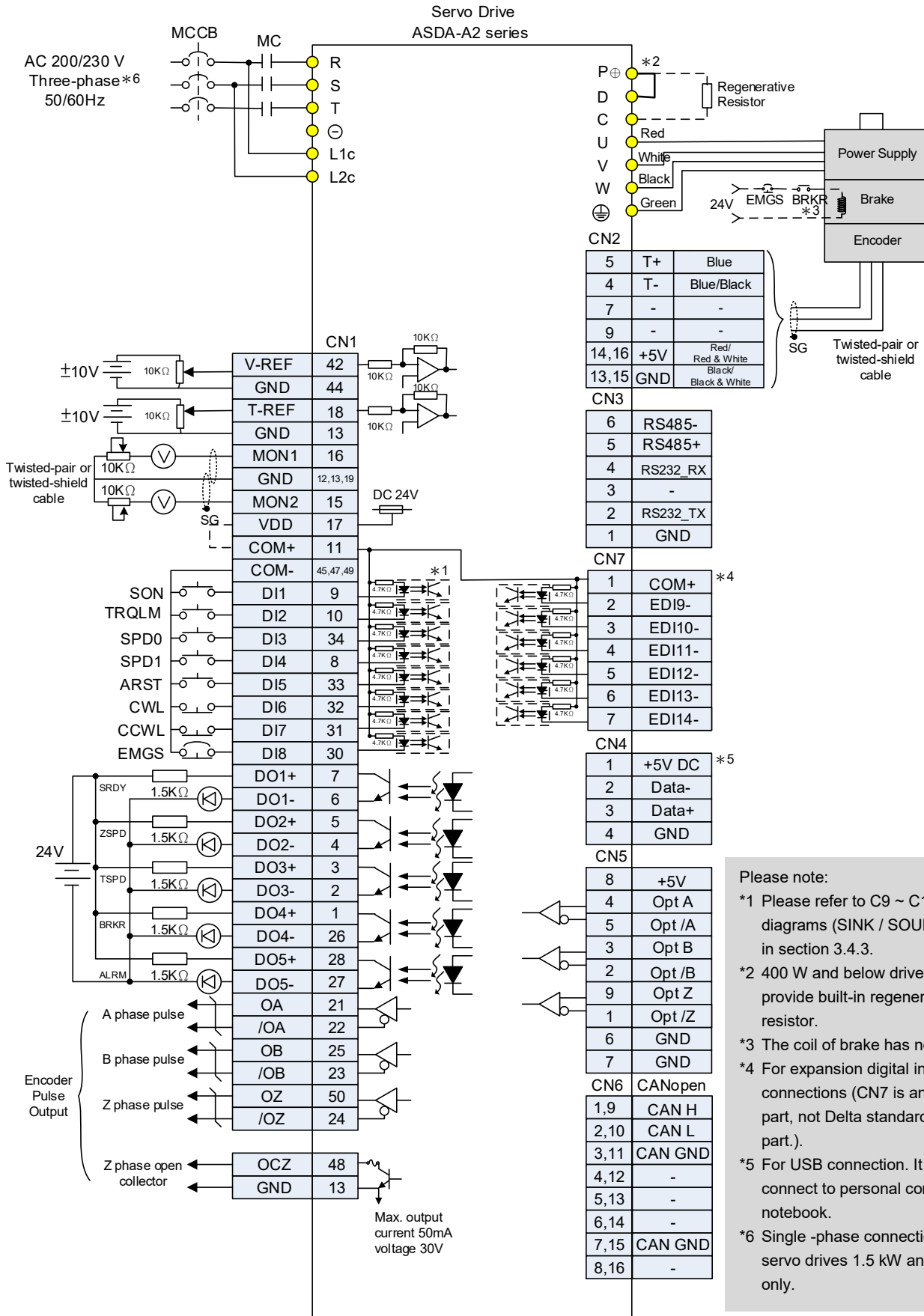

3.12.4 Torque Control Mode

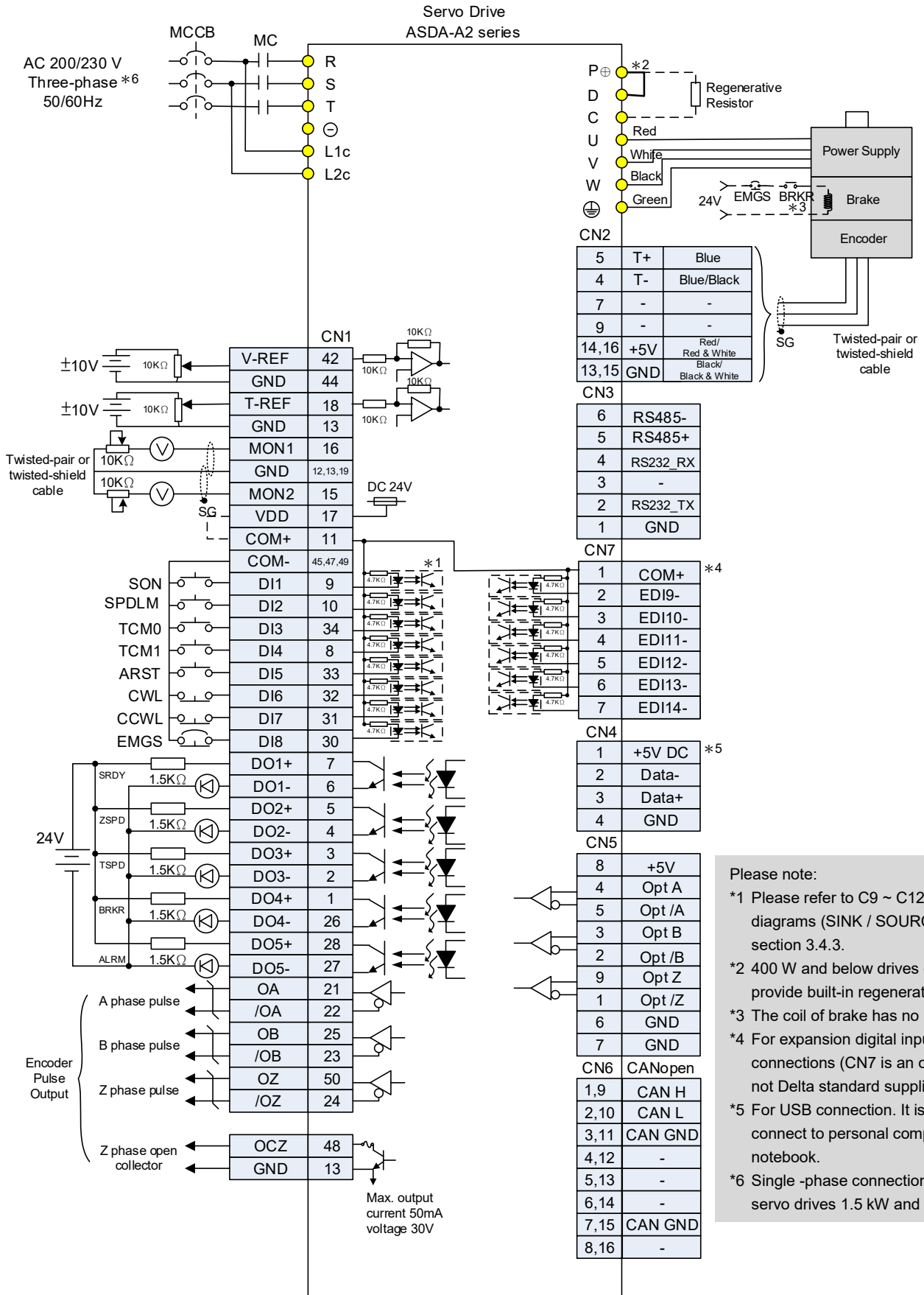

Please note:

- *1 Please refer to C9 ~ C12 wiring diagrams (SINK / SOURCE mode) in section 3.4.3.
- *2 400 W and below drives do not provide built-in regenerative resistor.
- *3 The coil of brake has no polarity.
- *4 For expansion digital inputs (DI) connections (CN7 is an optional part, not Delta standard supplied part.).
- *5 For USB connection. It is used to connect to personal computer or notebook.
- *6 Single -phase connections are for servo drives 1.5 kW and below only.

3.12.5 Communication Mode

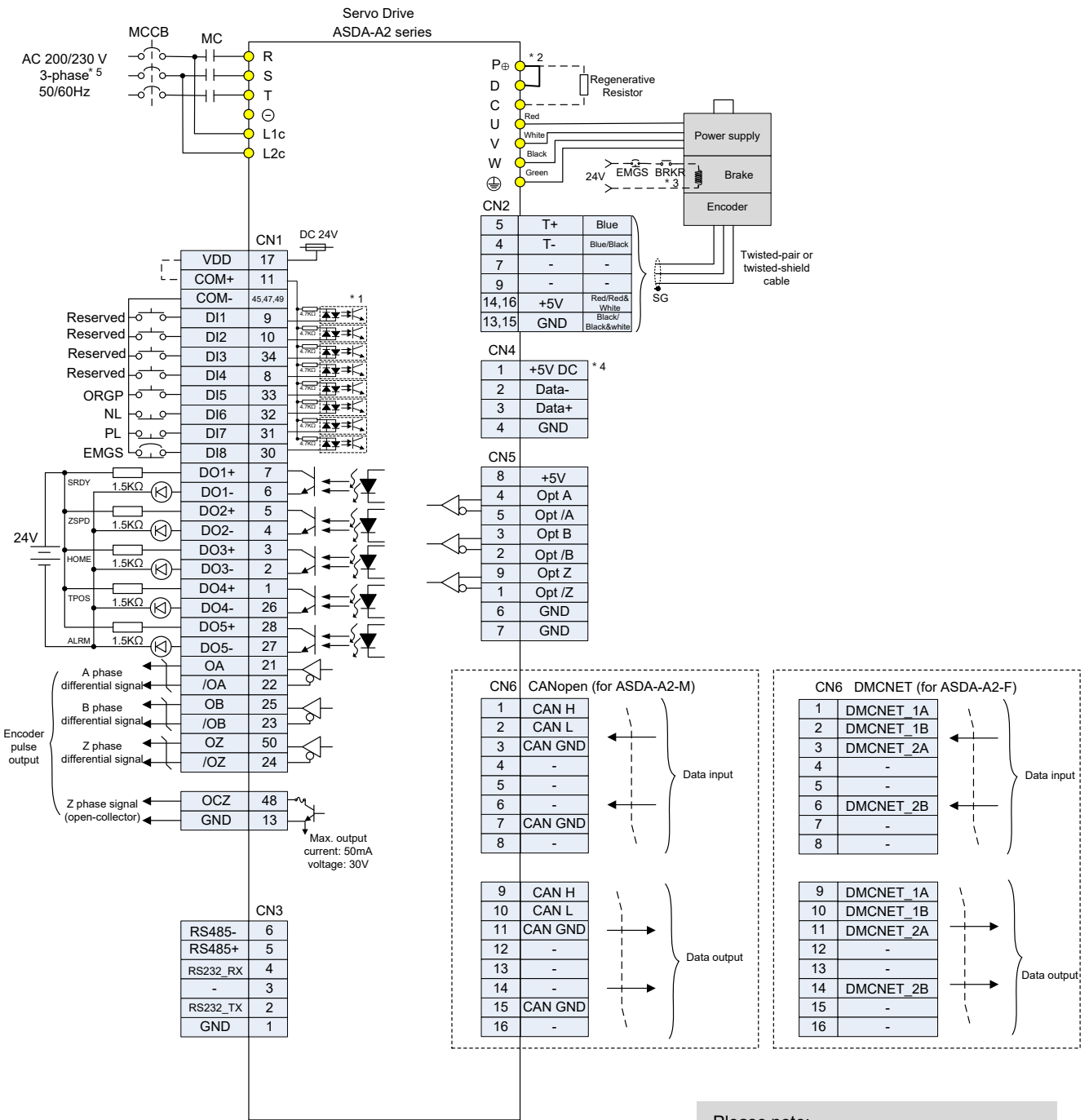

Please note:

- *1 Please refer to C9 ~ C12 wiring diagrams (SINK / SOURCE mode) in section 3.4.4.
- *2 400 W and below drives do not provide built-in regenerative resistor.
- *3 The coil of brake has no polarity.
- *4 For USB connection. It is used to connect to personal computer or notebook.
- *5 Single -phase connections are for servo drives 1.5 kW and below only.
- *6 A2-F only supports DMCNET mode.

3.13 Standard Connection Example – 400V series

3.13.1 Position (PT) Control Mode

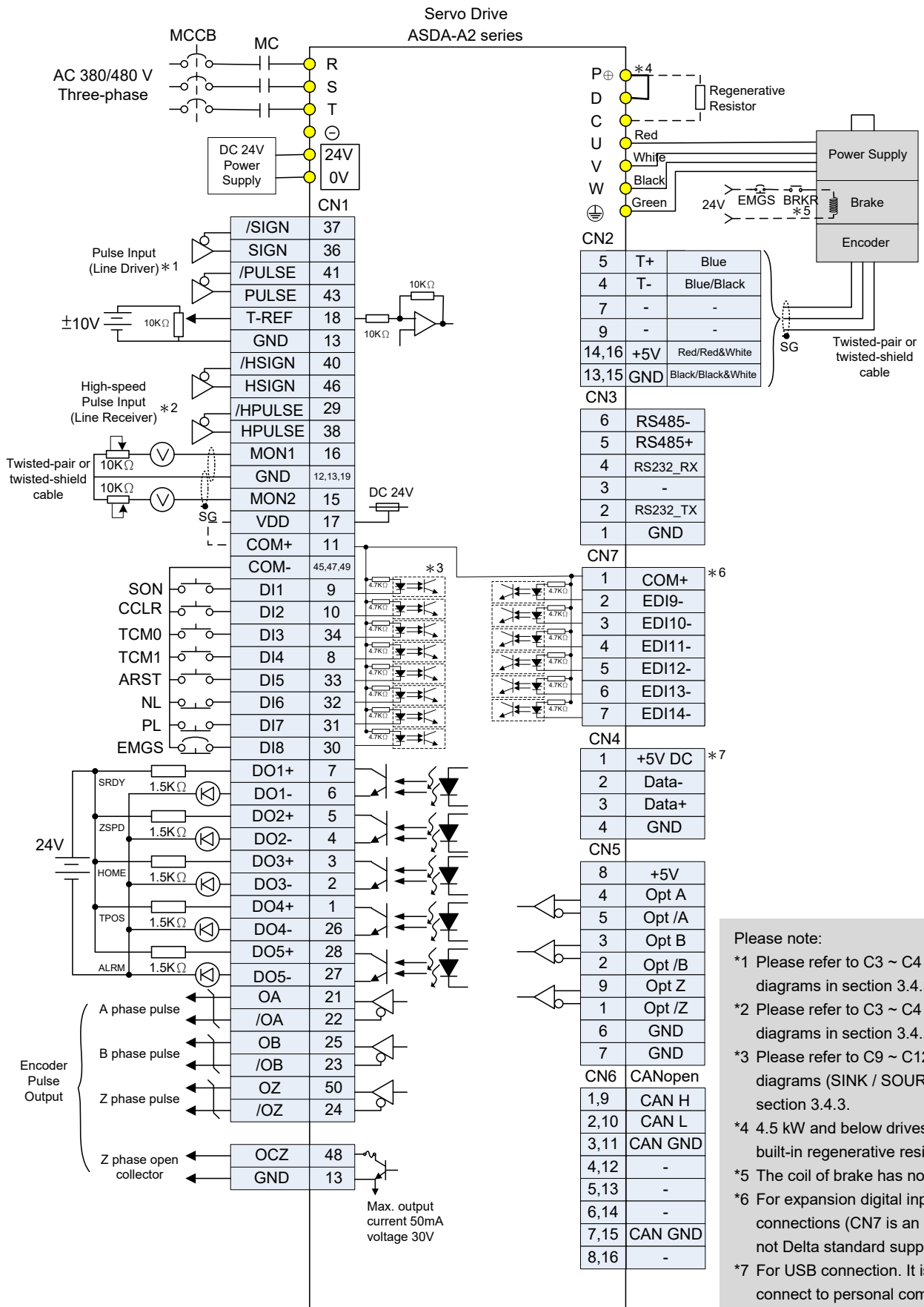

Please note:

- *1 Please refer to C3 ~ C4 wiring diagrams in section 3.4.3.
- *2 Please refer to C3 ~ C4 wiring diagrams in section 3.4.3.
- *3 Please refer to C9 ~ C12 wiring diagrams (SINK / SOURCE mode) in section 3.4.3.
- *4 4.5 kW and below drives provide built-in regenerative resistor.
- *5 The coil of brake has no polarity.
- *6 For expansion digital inputs (DI) connections (CN7 is an optional part, not Delta standard supplied part.).
- *7 For USB connection. It is used to connect to personal computer or notebook.

3.13.2 Position (PR) Control Mode

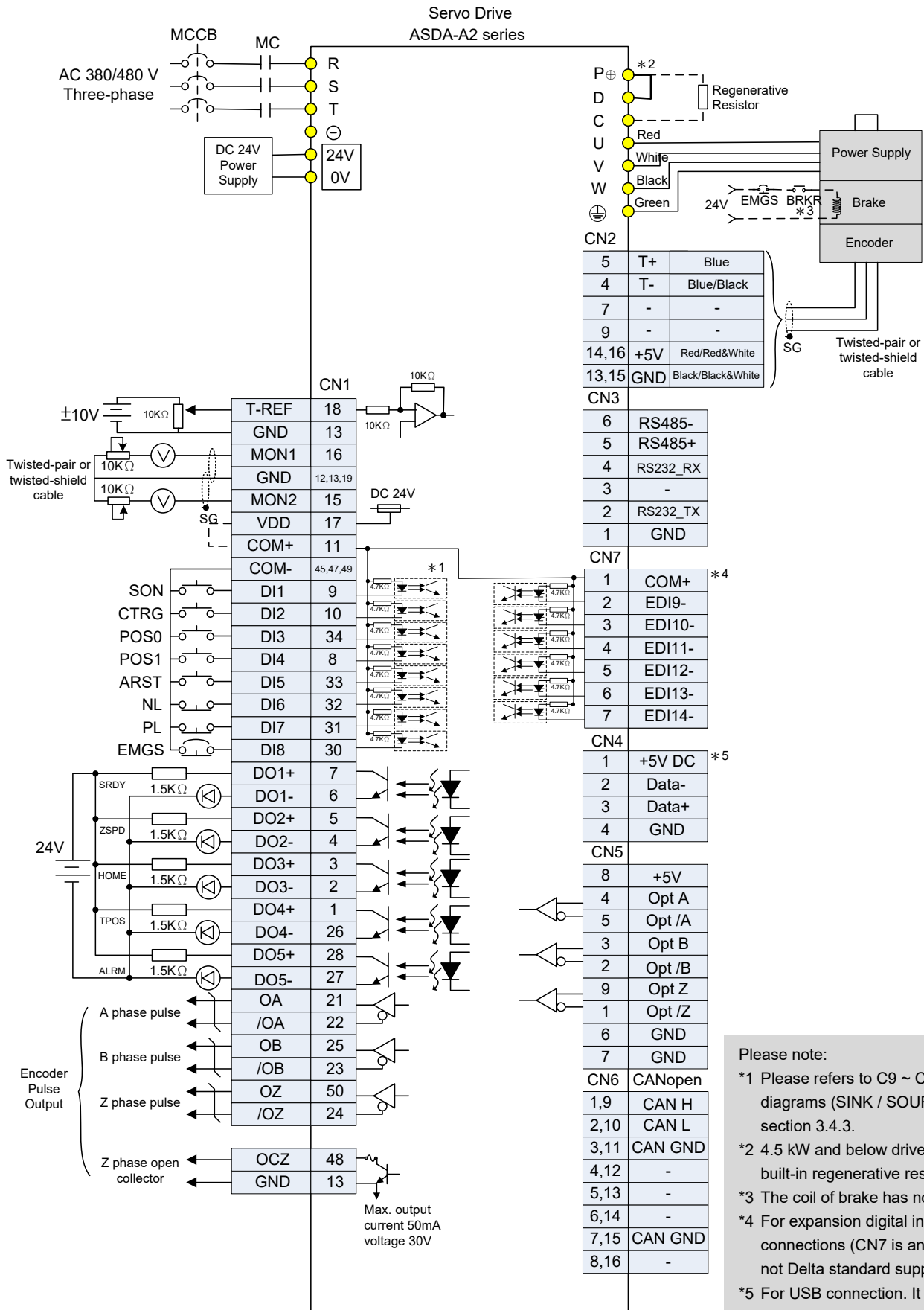

Please note:

- *1 Please refers to C9 ~ C12 wiring diagrams (SINK / SOURCE mode) in section 3.4.3.
- *2 4.5 kW and below drives provide built-in regenerative resistor.
- *3 The coil of brake has no polarity.
- *4 For expansion digital inputs (DI) connections (CN7 is an optional part, not Delta standard supplied part.).
- *5 For USB connection. It is used to connect to personal computer or notebook.

3.13.3 Speed Control Mode

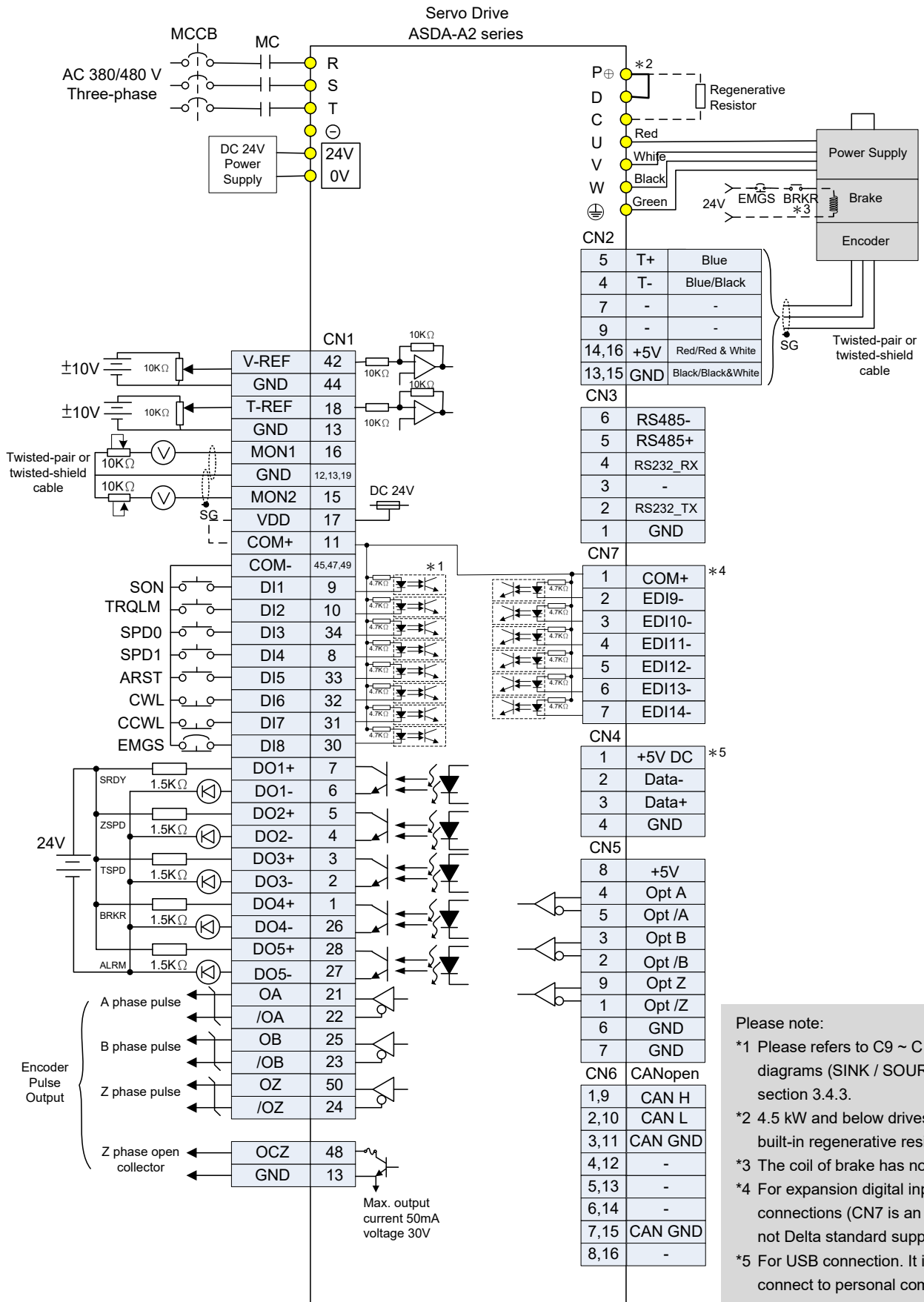

3.13.4 Torque Control Mode

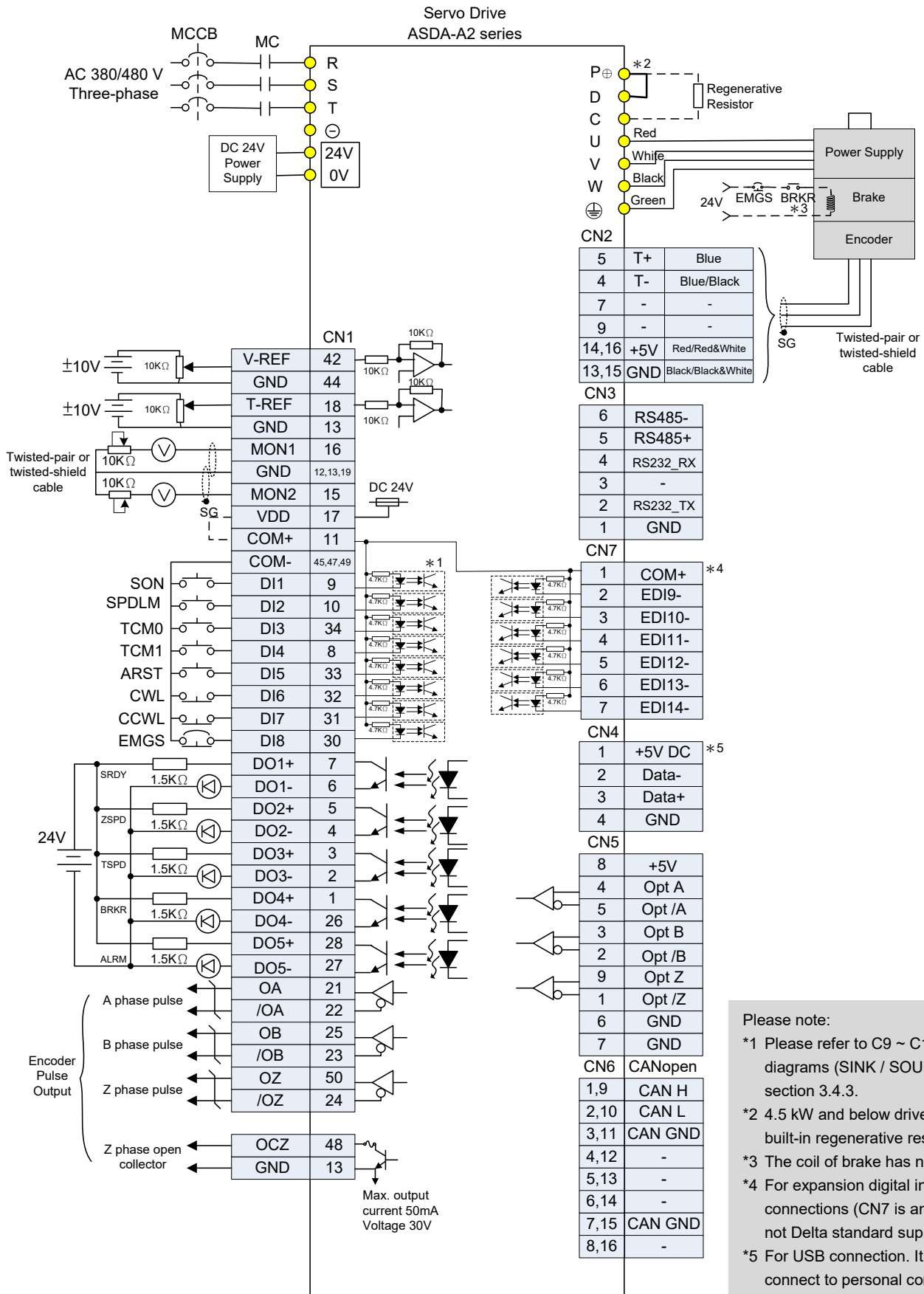

Please note:

- *1 Please refer to C9 ~ C12 wiring diagrams (SINK / SOURCE mode) in section 3.4.3.
- *2 4.5 kW and below drives provide built-in regenerative resistor.
- *3 The coil of brake has no polarity.
- *4 For expansion digital inputs (DI) connections (CN7 is an optional part, not Delta standard supplied part.).
- *5 For USB connection. It is used to connect to personal computer or notebook.

3.13.5 Communication Mode

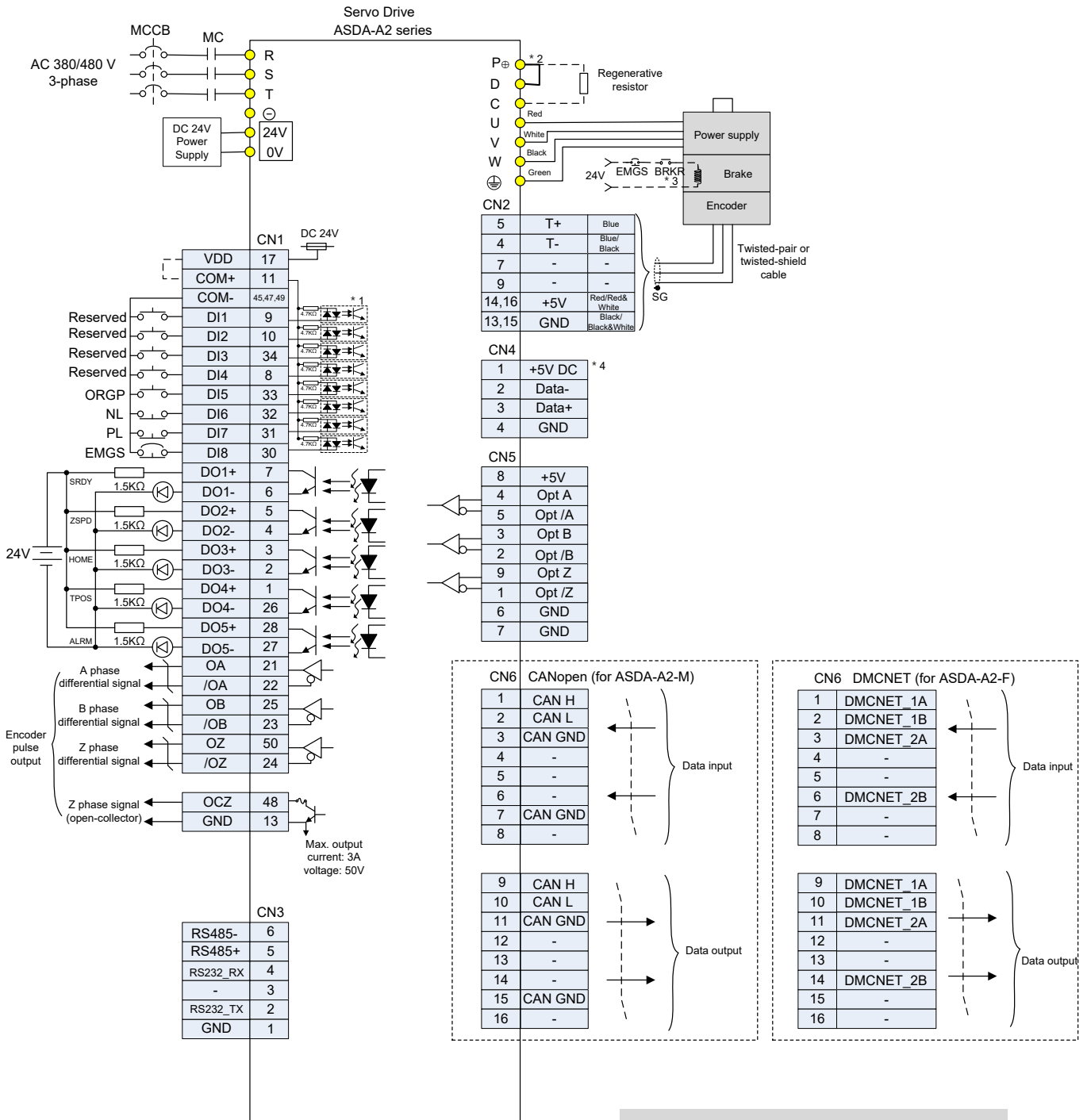

Please note:

- *1 Please refer to C9 ~ C12 wiring diagrams (SINK / SOURCE mode) in section 3.4.4.
- *2 4.5 kW and below drives provide built-in regenerative resistor.
- *3 The coil of brake has no polarity.
- *4 For USB connection. It is used to connect to personal computer or notebook.
- *5 A2-F only supports DMCNET mode.

3.14 Differences between A2-XN and A2 Series Servo Drives

The hardware connection structure of A2-XN series (X represents L, M, F, and N) is very similar to that of the A2 series. The following section illustrates their differences in detail.

3.14.1 Connecting to Peripheral Devices (A2-EN model as an example)

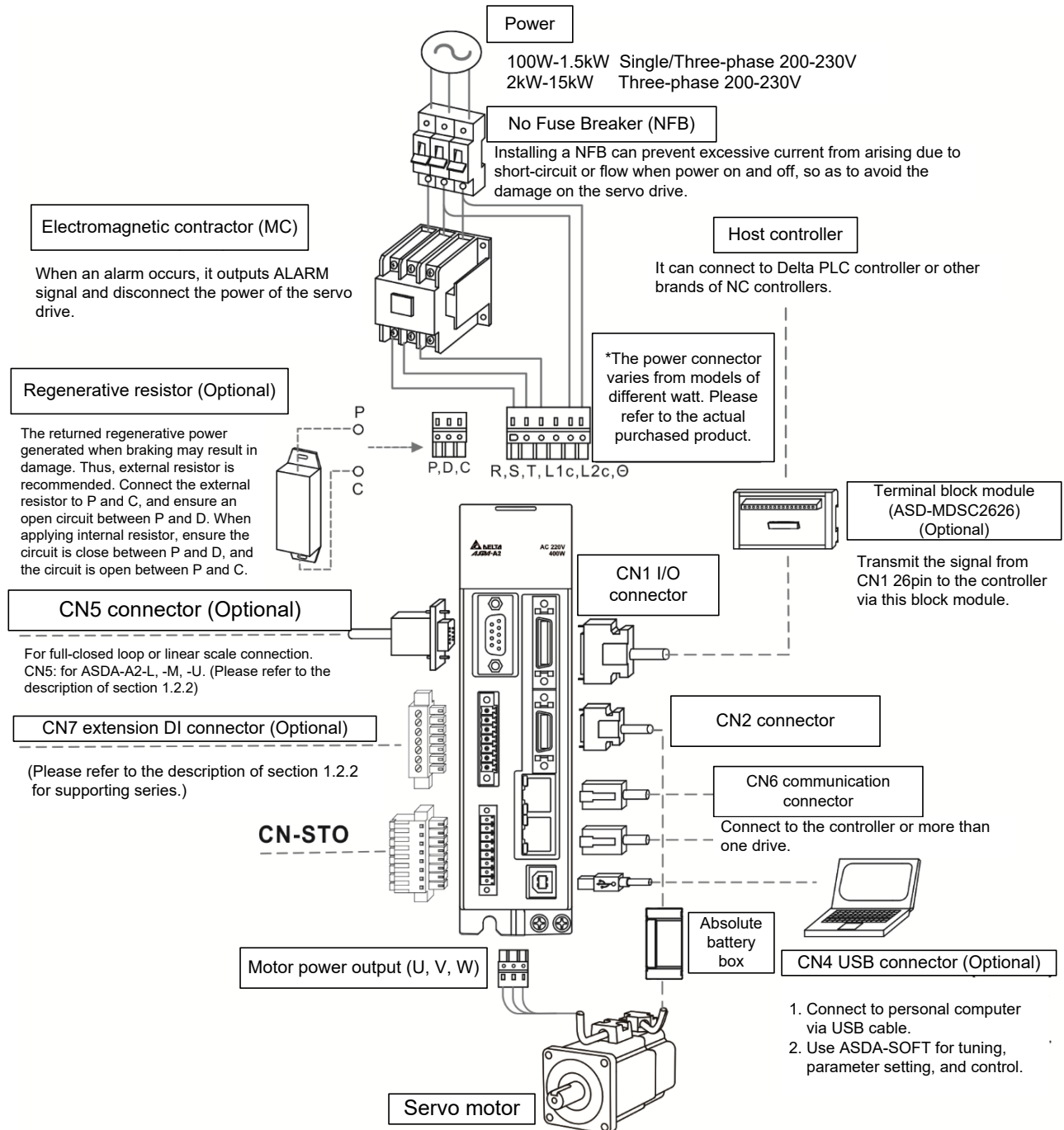

3.14.2 Connectors of A2-XN Servo Drives

Signal	Name	Description
CN-STO	CN-STO	STO connector; please refer to Section 3.14.9.

3.14.3 CN1 I/O 50-pin Connector (applicable to -LN series and 4.5 kW ~ 7.5 kW models of -FN and -MN series)

Delta provides 8 user-defined digital input (DI) points and 5 digital output (DO) points to provide highly flexible communication between the servo drive and the controller. The corresponding parameters for the 8 DI points and 5 DO points are P2-10 ~ P2-17 and P2-18 ~ P2-22. In addition, differential type output signals for encoder A+, A-, B+, B-, Z+, and Z-, as well as the analog torque command input and analog speed / position command input, and pulse position command input are provided. The pin assignments are shown as follows.

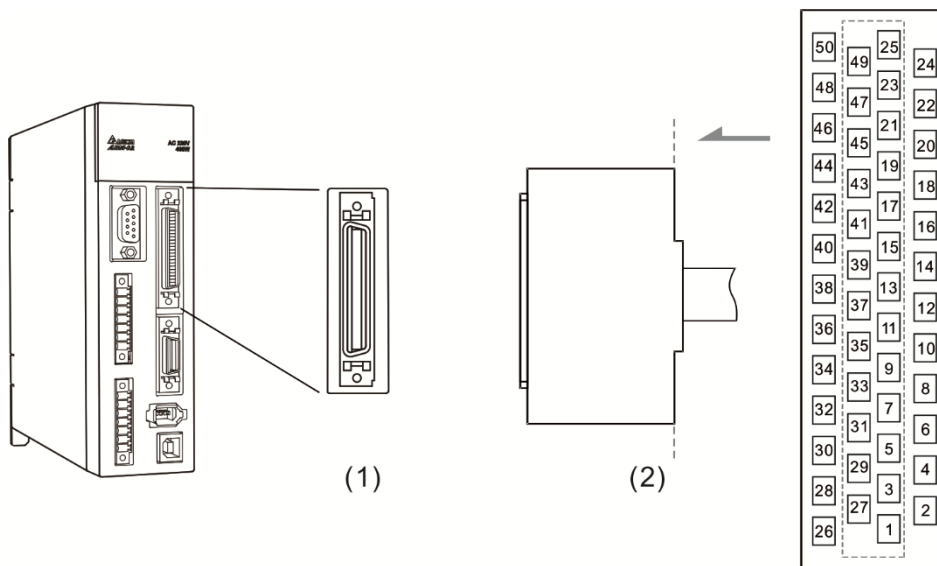

(1) CN1 connector (Female); (2) CN1 connector (Male)

Pin assignment:

2	DO3-	Digital output	1	DO4+	Digital output	26	DO4-	Digital output
4	DO2-	Digital output	3	DO3+	Digital output	27	DO5-	Digital output
6	DO1-	Digital output	5	DO2+	Digital output	28	DO5+	Digital output
8	DI4-	Digital input	7	DO1+	Digital output	29	/HPULSE	High speed position command pulse (-)
10	DI2-	Digital input	9	DI1-	Digital input	30	DI8-	Digital input
12	GND	Analog input signal ground	11	COM+	Power input (12~24V)	31	DI7-	Digital input
14	NC	Not in use	13	GND	GND for analog input signal	33	DI5-	Digital input
16	MON1	Analog monitor output 1	15	MON2	Analog monitor output 2	35	PULL HI_S (Sign)	External power input of Sign pulse
18	T_REF	Analog command input torque	17	VDD	+24V Power output (for external I/O)	37	/SIGN	Position sign (-)
20	VCC	+12V Power output (for analog command)	19	GND	Analog input signal ground	39	PULL HI_P (Pulse)	External power input of pulse
22	/OA	Encoder /A pulse output	21	OA	Encoder A pulse output	41	/PULSE	Position pulse (-)
24	/OZ	Encoder /Z pulse output	23	/OB	Encoder /B pulse output	43	PULSE	Position pulse (+)
			25	OB	Encoder B pulse output	45	COM-	VDD (24V) power ground
						47	COM-	VDD (24V) power ground
						49	COM-	VDD (24V) power ground
						46	HSIGN	High speed position command sign (+)
						48	OCZ	Encoder Z pulse open-collector output
						50	OZ	Encoder Z pulse line-driver output
						40	/HSIGN	High speed position sign (-)
						36	SIGN	Position sign (+)
						38	HPULSE	High speed position pulse (+)
						34	DI3-	Digital input
						32	DI6-	Digital input
						42	V_REF	Analog command input speed (+)
						44	GND	Analog input signal ground

Note: NC represents “No connection”, which is for internal use only. Do not connect to NC or it may damage the servo drive.

3.14.4 CN1 I/O 26-pin Connector (applicable to -EN series and 3 kW models or below of -FN and -MN Series)

Delta provides 7 user-defined digital input (DI) points and 4 digital output (DO) points to provide highly flexible communication between the servo drive and the controller. The corresponding parameters for the 7 DI points and 4 DO points are P2-10 ~ P2-16 and P2-18 ~ P2-21. In addition, differential type output signals for encoder A+, A-, B+, B-, Z+, and Z- are provided. The pin assignments are shown as follows.

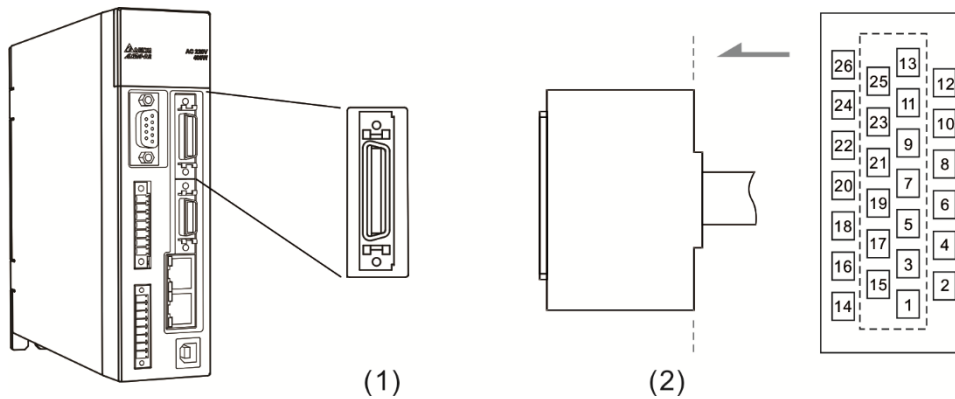

(1) CN1 connector (Female); (2) CN1 connector (Male)

2	DO1-	Digital output	1	DO1+	Digital output	15	NC	Not in use	14	COM-	VDD ground
4	DO2-	Digital output	3	DO2+	Digital output	17	OA	Encoder A pulse output	16	GND	Analog input signal ground
6	COM+	Power input (12 ~ 24V)	5	VDD	+24 Power output	19	OB	Encoder B pulse output	18	/OA	Encoder /A pulse output
8	DI2-	Digital input	7	DI1-	Digital input	21	OZ	Encoder Z pulse output	20	/OB	Encoder /B pulse output
10	DI4-	Digital input	9	DI3-	Digital input	23	DO4+	Digital output	22	/OZ	Encoder /Z pulse output
12	DI6-	Digital input	11	DI5-	Digital input	25	DO3+	Digital output	24	DO4-	Digital output
			13	DI7-	Digital input				26	DO3-	Digital output

Note: NC represents “No connection”, which is for internal use only. Do not connect to NC or it may damage the servo drive.

3.14.5 CN3 Communication Connector (applicable to -LN series and 4.5 kW ~ 7.5 kW models of -FN and -MN series)

When the servo drive is connected to the PC via CN3, you can operate the servo drive, PLC, or HMI through MODBUS using the assembly language. The CN3 connector supports the communication interfaces RS-485 and enables you to connect to multiple servo drives simultaneously. You can also set P3-05 to transmit data at a longer distance.

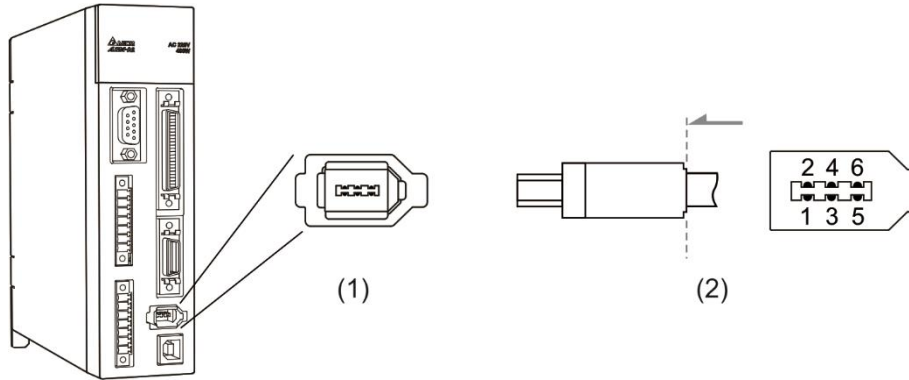

(1) CN3 connector (Female); (2) CN3 connector (Male)

Pin No.	Name	Signal	Function
1	Signal ground	GND	+5V and signal terminal GND
2	-	-	Reserved
3	-	-	Reserved
4	-	-	Reserved
5	RS-485 data transmission	RS-485(+)	The servo drive transmits the data to differential terminal (+)
6	RS-485 data transmission	RS-485(-)	The servo drive transmits the data to differential terminal (-)

Note:

1. Please refer to page 9-2 for RS-485 wiring.
2. There are two types of IEEE1394 communication cables commercially available, one is that the internal ground (Pin 1) is short-circuited with the shielding; if this type of connector would damage the communication cable, do not short-circuit the ground on the communication cable with the terminal case.

3.14.6 EtherCAT Communication Connector (applicable to -EN models)

A2-XN provides two ports (input and output) for servo drives connected in series.

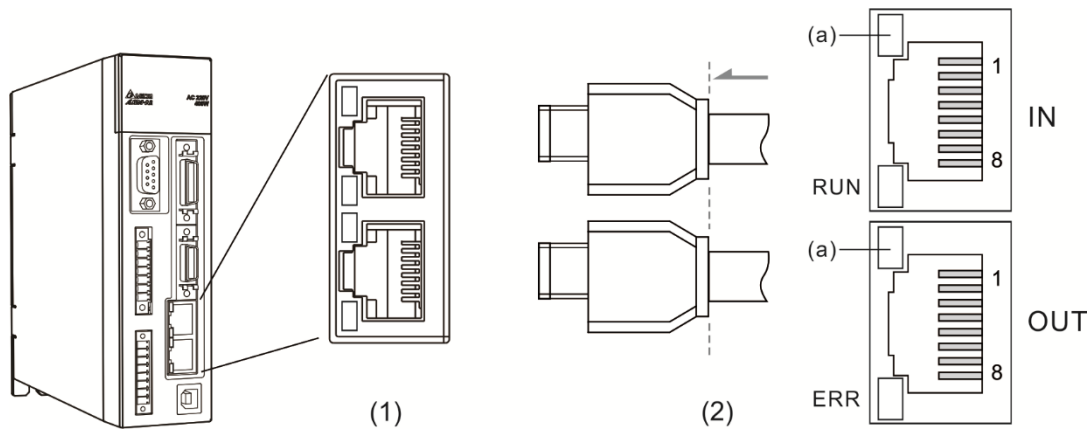

(1) CN6 connector (Female); (2) CN6 connector (Male) (a) Network status indicator

CN6 pin assignment:

Pin No.	Name	Signal	Function
1	TX +	TX +	Transmit +
2	TX -	TX -	Transmit -
3	RX +	RX +	Receive +
4	-	-	-
5	-	-	-
6	RX -	RX -	Receive -
7	-	-	-
8	-	-	-

CN6 indicator:

■ Network status indicator

Indicator Status	Definition	Description
On	Connecting	Connection is established without data transmission
Blink	Connected and data transmission in progress	Data transmission in progress
Off	No connection	Connection is not established

■ EtherCAT connection status indicator (RUN)

Indicator Status	Definition	Description
Off	Initial	After powering on, the EtherCAT device is initialized and the communication is not established, but the controller can still access the register of the device.
On	Operational	Transmitting SDO, TxPDO, and RxPDO data packets is allowed.
Blinking	Pre-Operational	The controller can exchange data through Mailbox.
Single Flash	Safe-Operational	The device can use SDO and TxPDO data packets to exchange data with the controller.

■ EtherCAT error indicator (ERR)

Indicator Status	Definition	Description
Off	No error	No error.
On	PDI Watchdog timeout	Device malfunction; please contact your distributor.
Blinking	State change error	State switching error caused by wrong parameter setting. Please refer to the diagram below.
Single Flash	Synchronization error / SyncManager error	Synchronization failure of the controller and device or data is lost during data receiving.

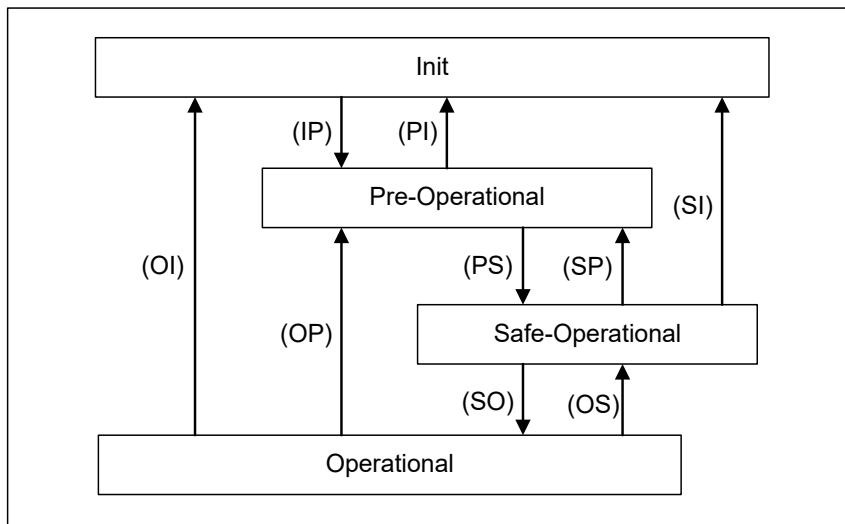

Status switch diagram

Connect to multiple servo drives:

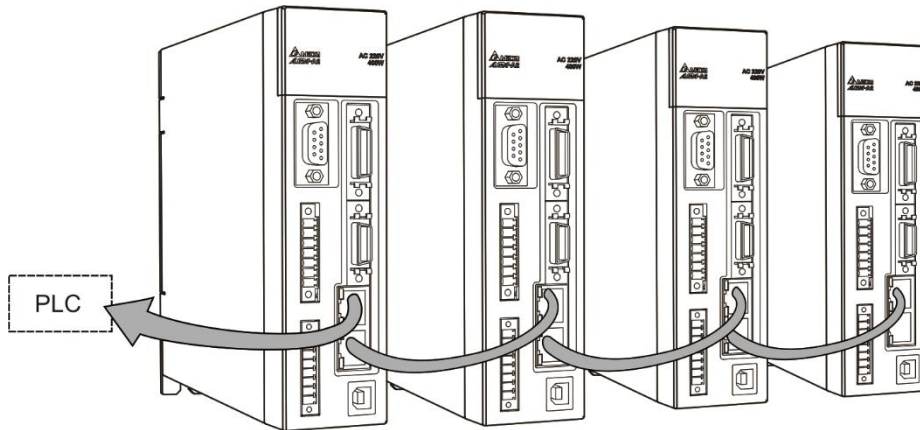

Note:

1. When connecting multiple servo drives in serial, the maximum distance between each servo drive is 50 m (164.04 feet).
2. Please use CAT5e STP shielded cable.
3. Beckhoff cable is recommended (model type: ZB9020).

3.14.7 CN-STO (Safe Torque Off)

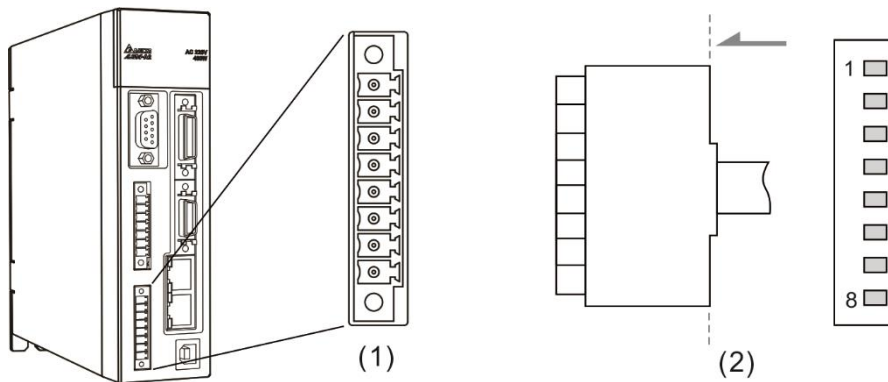

(1) CN-STO connector (Female); (2) CN-STO connector (Male)

Note: STO certification application is in progress.

Pin No	Signal	Function
*1	COM+	VDD(24V) power, which is identical to Pin 5 on CN1
2	STO_A	STO input A+
3	/STO_A	STO input A-
4	STO_B	STO input B+
5	/STO_B	STO input B-
6	FDBK_A	STO alarm output A, Relay output, N.C. Max. current: 30 V _{DC} , 1 A 125 V _{AC} , 0.3 A
7	FDBK_B	STO alarm output B, Relay output, N.C. Max. current: 30 V _{DC} , 1 A 125 V _{AC} , 0.3 A
8	COM-	VDD(24V) power ground



* **Caution: Do not use dual power supply or it might damage the servo drive.**

3.14.8 How does the STO Function Work?

The STO function is controlled by the motor current from two individual circuits. It cuts off the power supply to the motor when needed, after which the motor is free from torque force. The table below details how this function works.

Actions description (ON = 24V; OFF = 0V)

Note: STO certification application is in progress.

Signal	Channel	Status of opto-isolator			
STO	STO_A ~ / STO_A	ON	ON	OFF	OFF
	STO_B ~ / STO_B	ON	OFF	ON	OFF
Servo Drive Output Status		Ready	Torque off (STO_B lost)	Torque off (STO_A lost)	Torque off (STO Mode)

(1) Description of the STO alarm:

See the diagram below. When the motor runs normally (Servo On), but both STO_A and STO_B signals are lost for 10 ms at the same time, AL500 occurs and the drive is in the Servo Off state.

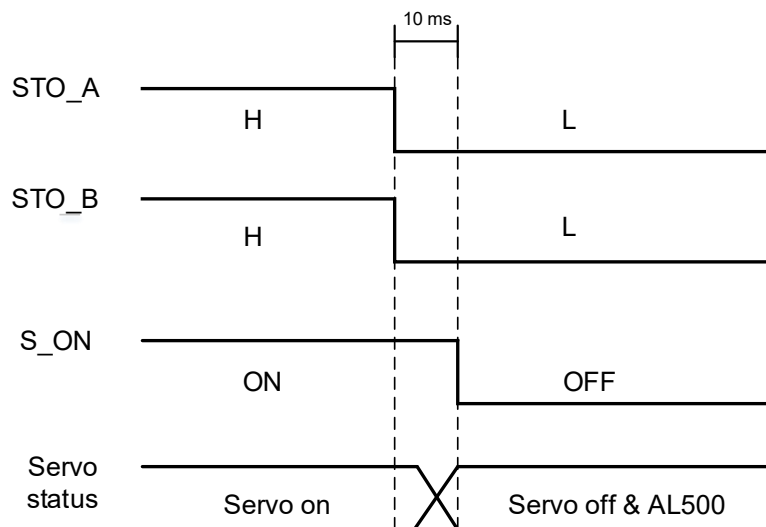

When the motor runs normally (Servo On), but one of the safety signal source is lost for 1 s, AL501 or AL502 occurs. Then the servo drive is in the Servo Off state.

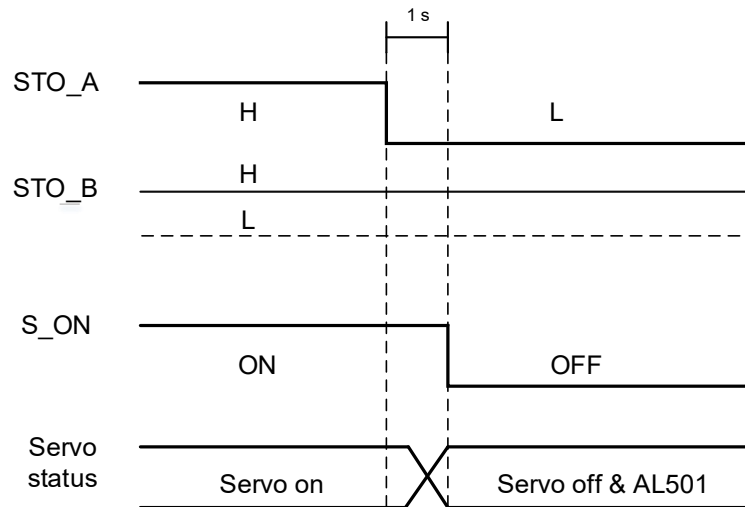

3.14.9 Related Parameter of the STO Function

By setting parameter P2-93, you can determine the FDBK status (Pin FDBK+ and FDBK-) and whether FDBK latches if an STO alarm occurs. The settings for P2-93 are shown as below:

$$P2-93 = \frac{XX}{(1)} \frac{1}{(2)} \frac{0}{(3)}$$

- (1) Not in use
- (2) 1: FDBK no latch
2: FDBK latch
- (3) 0: Logic A
1: Logic B
2: Logic C
3: Logic D

STO function description:

See the table below. Four logic conditions (Logic A, B, C, and D) are available to standardize the FDBK status when different STO alarms occur. You can select the corresponding logic according to the needs of the application. In this table, "Open" means FDBK+ and FDBK- of CN8 are an open circuit. Take Logic C as an example. When AL500 occurs, FDBK+ and FDBK- of CN8 are short-circuited.

Servo drive status		FDBK status							
		Logic A		Logic B		Logic C		Logic D	
Parameter P2-93		XX10	XX20	XX11	XX21	XX12	XX22	XX13	XX23
FDBK behavior		No Latch	Latch	No Latch	Latch	No Latch	Latch	No Latch	Latch
No STO alarm		Open		Close		Open		Close	
Alarm occurs	AL500	Close		Open		Close		Open	
	AL501	Close		Open		Open		Close	
	AL502	Close		Open		Open		Close	
	AL503	Close		Open		Open		Close	

Note:

1. Open = open circuit; Close = short circuit
2. Please refer to Chapter 10 Troubleshooting for more details.

FDBK behavior (Latch / No Latch):

If FDBK is latched when the STO alarm occurs, the status of FDBK does not change even when the alarm is cleared. Please note that when more than one alarm occurs, the drive panel only shows AL500.

■ Example of Latching:

If Logic C P2-93 = XX22 is set, the FDBK status is closed when safety signal is lost and AL005 occurs.

1. Since FDBK is selected as Latch, even when the safety signal is back to normal, the FDBK status remains closed. To reset FDBK:
 - (1) Reconnect the power supply: FDBK status returns to "open".
 - (2) Do not reconnect the power supply. Instead, set P2-93 to XX12 to make the FDBK status return to "open". Then set P2-93 to XX22 again. This step sets the FDBK behavior to Latch.
2. After the FDBK status is restored, you can clear the alarms by the normal corrective actions. In this case, you can clear AL500 by DI.Alm Reset.

■ Example of not latching:

If Logic C P2-93 is set to XX12, the FDBK status is closed when the safety signal is lost and AL500 occurs.

1. Since FDBK is selected as No Latch, when the safety signals return to normal, the FDBK status automatically changes from short-circuited to normal when AL500 occurs. Setting P2-93 to XX12 again is not required.
2. After the FDBK status is restored, you can clear the alarms by the normal corrective actions. In this case, you can clear AL500 by DI.Alm Reset.

Relevant parameter (Please refer to Chapter 8 for detailed information):

Parameter	Function
P2-93	STO FDBK Control

3.14.10 Position (PT) Control Mode

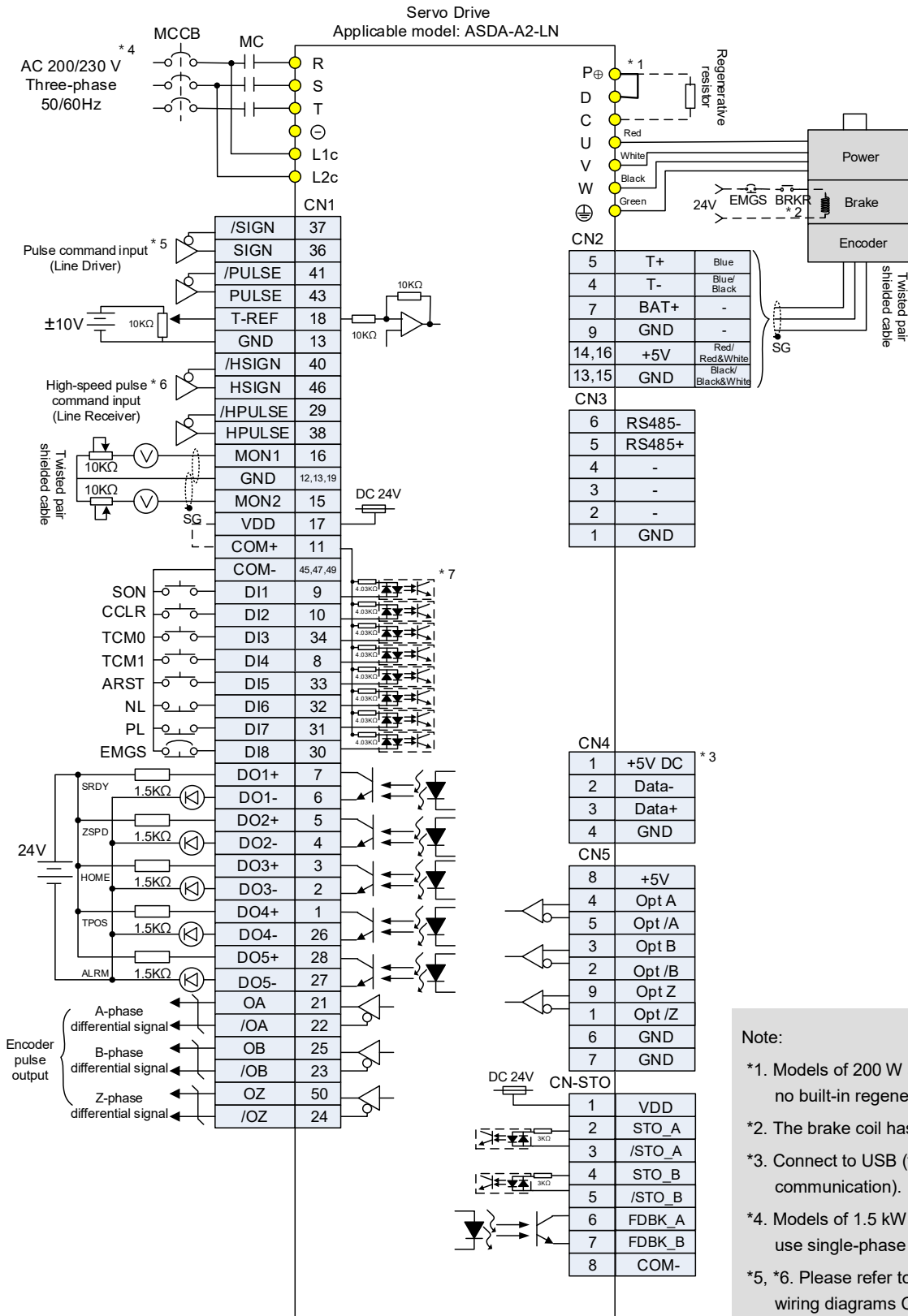

3.14.11 Position (PR) Control Mode

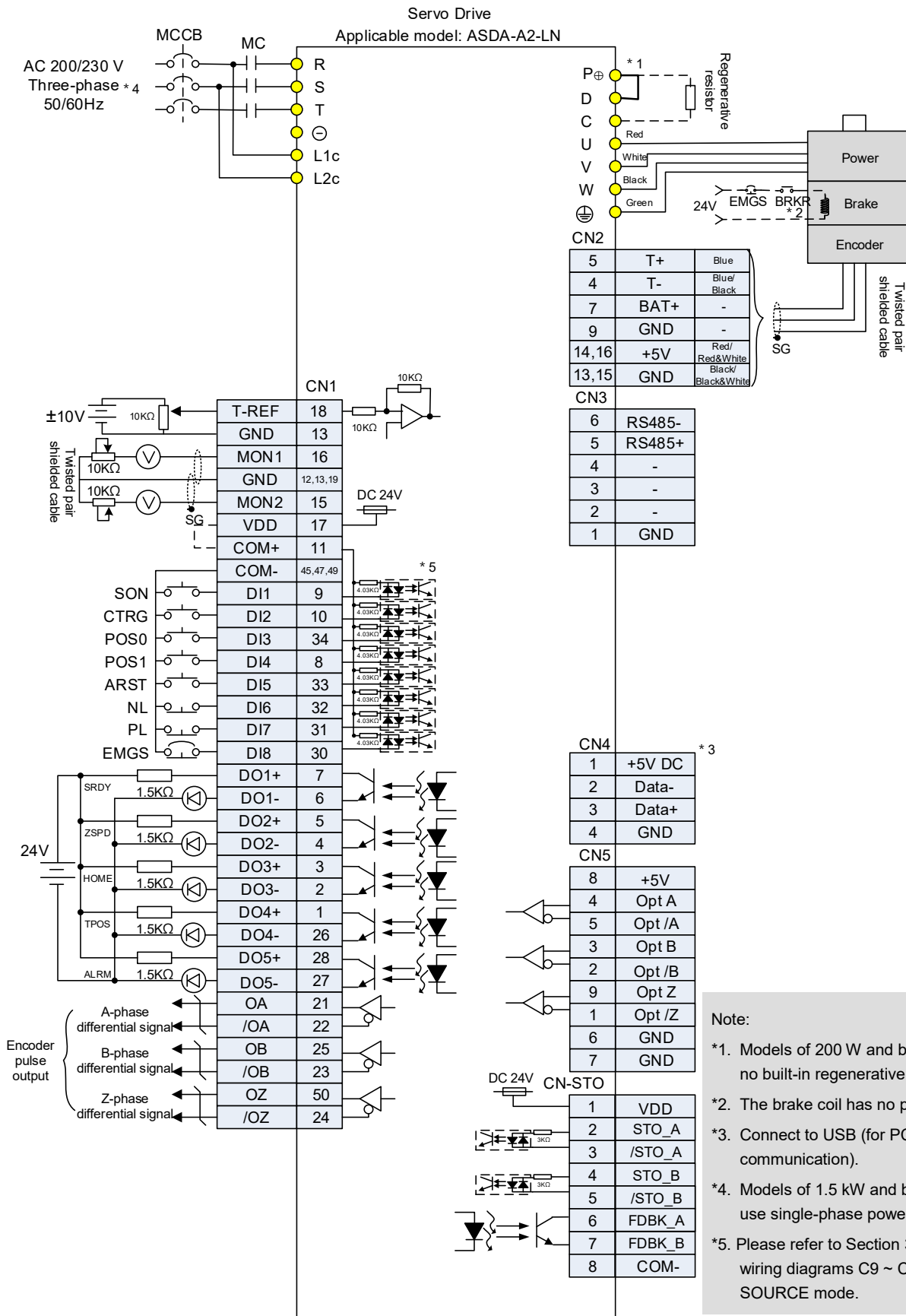

Note:

- *1. Models of 200 W and below have no built-in regenerative resistor.
- *2. The brake coil has no polarity.
- *3. Connect to USB (for PC communication).
- *4. Models of 1.5 kW and below can use single-phase power supply.
- *5. Please refer to Section 3.3.3 for wiring diagrams C9 ~ C12 SINK / SOURCE mode.

3.14.12 Speed Control Mode

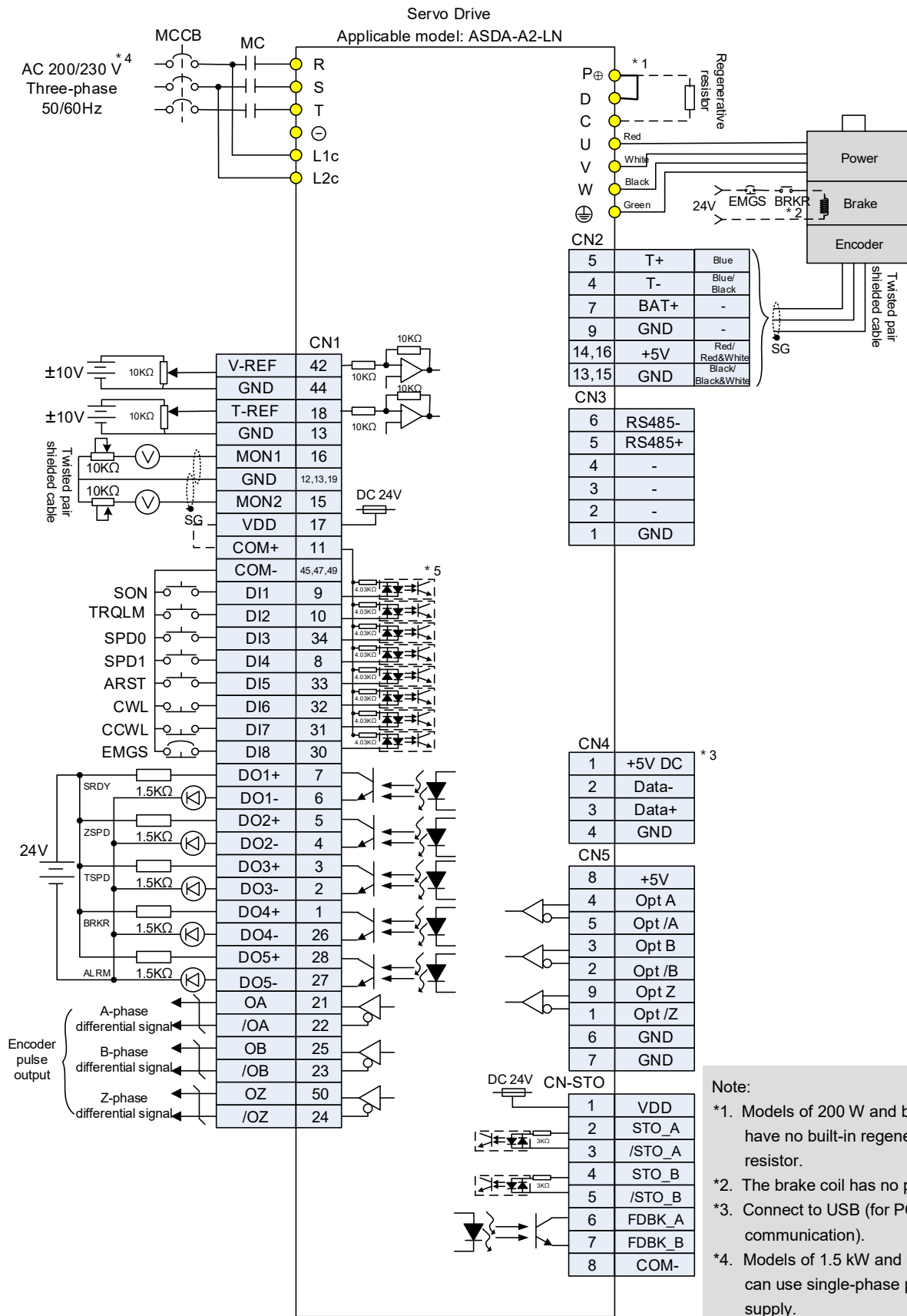

Note:

- *1. Models of 200 W and below have no built-in regenerative resistor.
- *2. The brake coil has no polarity.
- *3. Connect to USB (for PC communication).
- *4. Models of 1.5 kW and below can use single-phase power supply.
- *5. Please refer to Section 3.3.3 for C9 ~ C12 wiring diagrams SINK / SOURCE mode.

3.14.13 Torque Control Mode

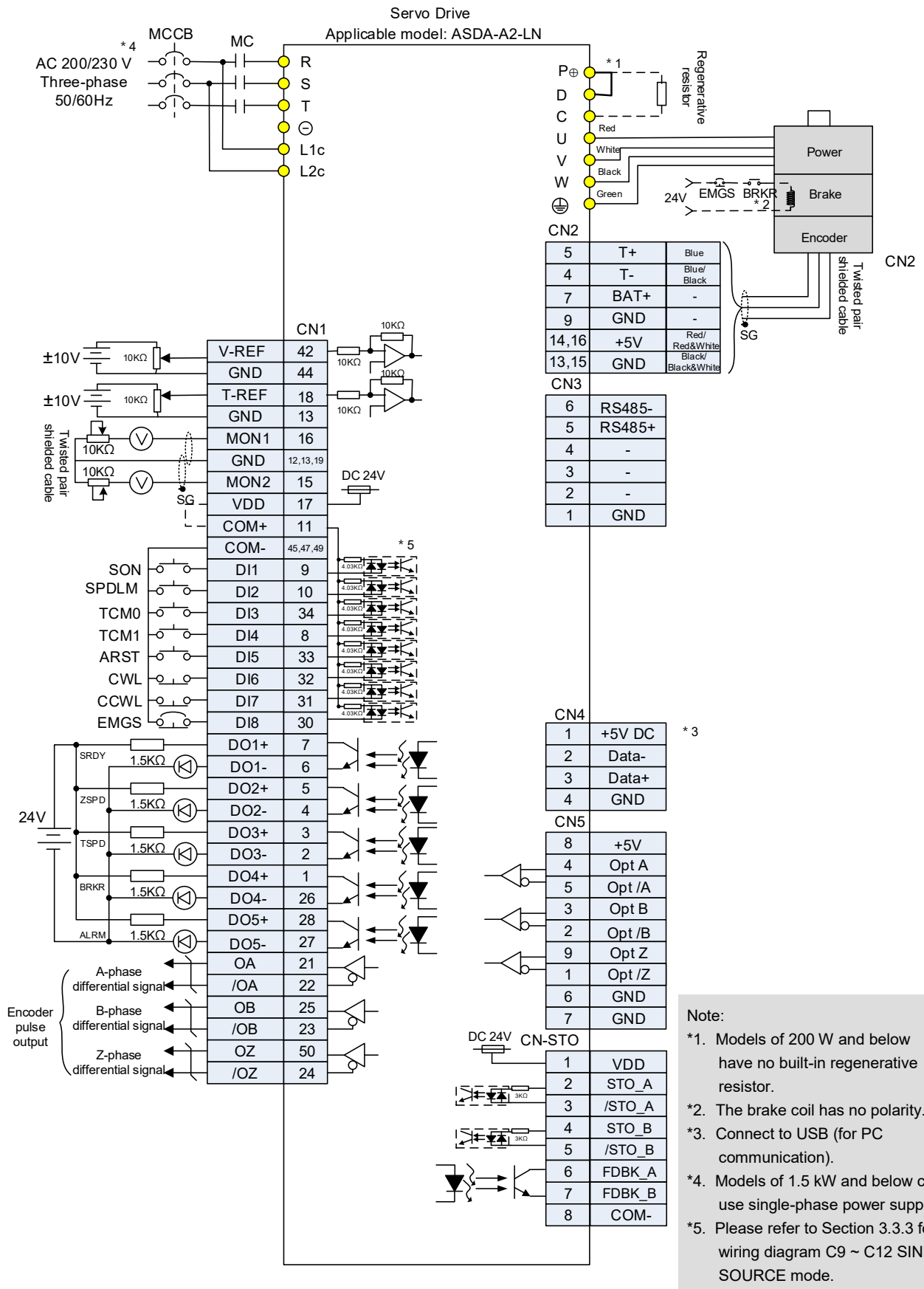

Note:

- *1. Models of 200 W and below have no built-in regenerative resistor.
- *2. The brake coil has no polarity.
- *3. Connect to USB (for PC communication).
- *4. Models of 1.5 kW and below can use single-phase power supply.
- *5. Please refer to Section 3.3.3 for wiring diagram C9 ~ C12 SINK / SOURCE mode.

3.14.14 Communication Mode

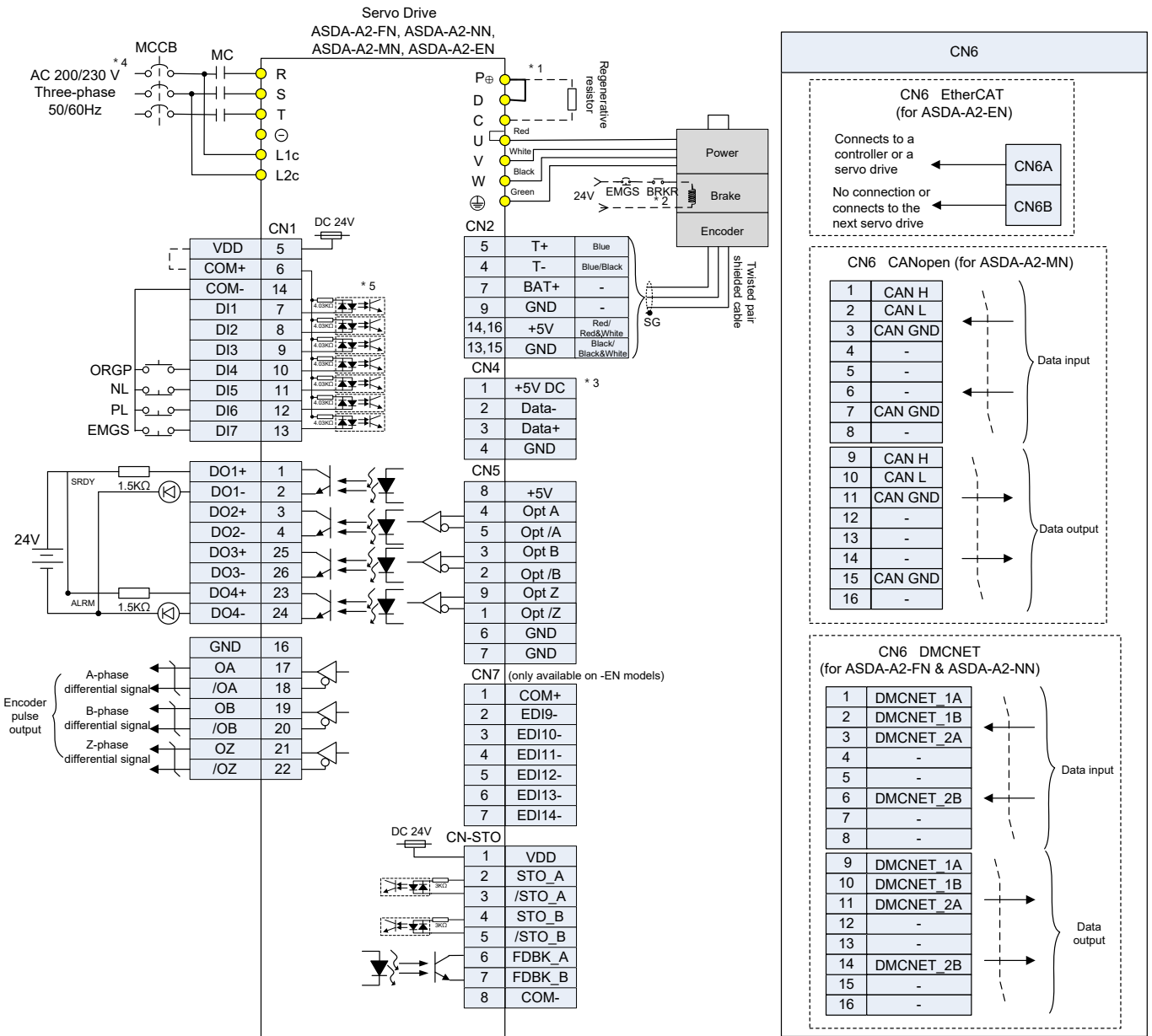

- Note:**
- *1. Models of 200 W and below have no built-in regenerative resistor.
 - *2. The brake coil has no polarity.
 - *3. Connect to USB (for PC communication).
 - *4. Models of 1.5 kW and below can use single-phase power supply.
 - *5. Please refer to Section 3.4.3 for wiring diagram C5 ~ C8 SINK / SOURCE mode.

Chapter 4 Panel Display and Operation

This chapter details the panel status and operation of ADSA-A2 series servo drive.

4.1 Panel Description

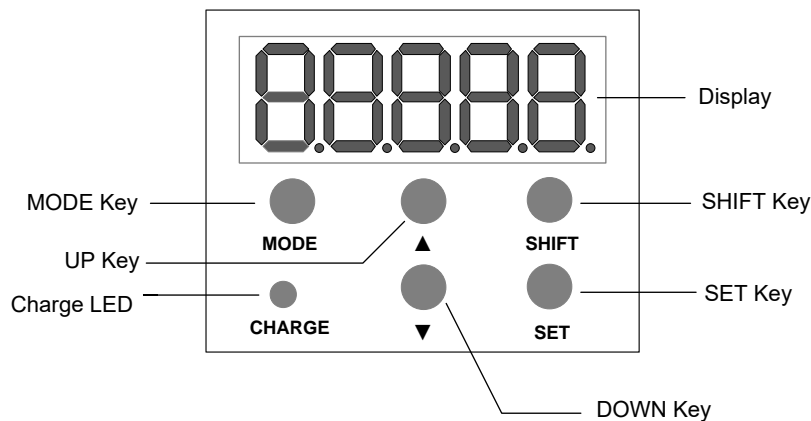

Name	Function
Display	Five-/Seven-segment display is for displaying the monitoring values, parameter values, and setting values.
SHIFT Key	In Parameter mode, use this key to change the group number. In Editing mode, moving the flashing (selected) digit to the left lets you adjust the higher setting bit. You can switch the display of high / low digis in Monitoring mode.
SET Key	Pressing the SET key can display and save the parameter groups and various parameter settings. In Monitoring mode, pressing SET key can switch decimal or hexadecimal display. In Parameter mode, pressing SET key can enter into parameter setting mode.
DOWN Key	Pressing the DOWN key can scroll through and change monitor codes, parameter groups, and various parameter settings.
MODE Key	Pressing the MODE key can enter or exit different parameter groups, and switch between Monitoring mode and Parameter mode.
UP Key	Pressing the UP key can scroll through and change monitor codes, parameter groups, and various parameter settings.
Charge LED	The Charge LED lights to indicate the power is applied to the circuit.

4.2 Parameter Setting Procedure

Switch the mode:

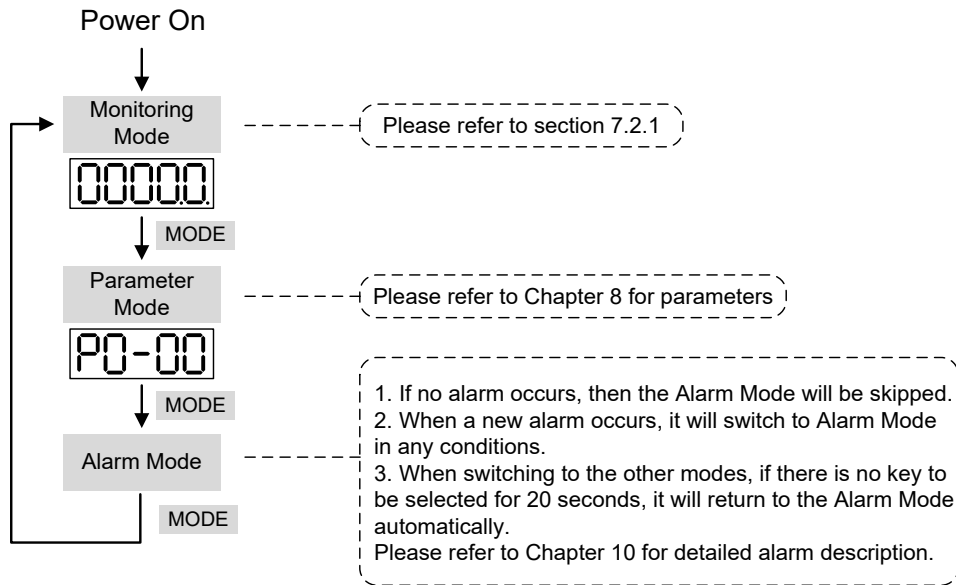

Operate in each mode:

Monitoring mode

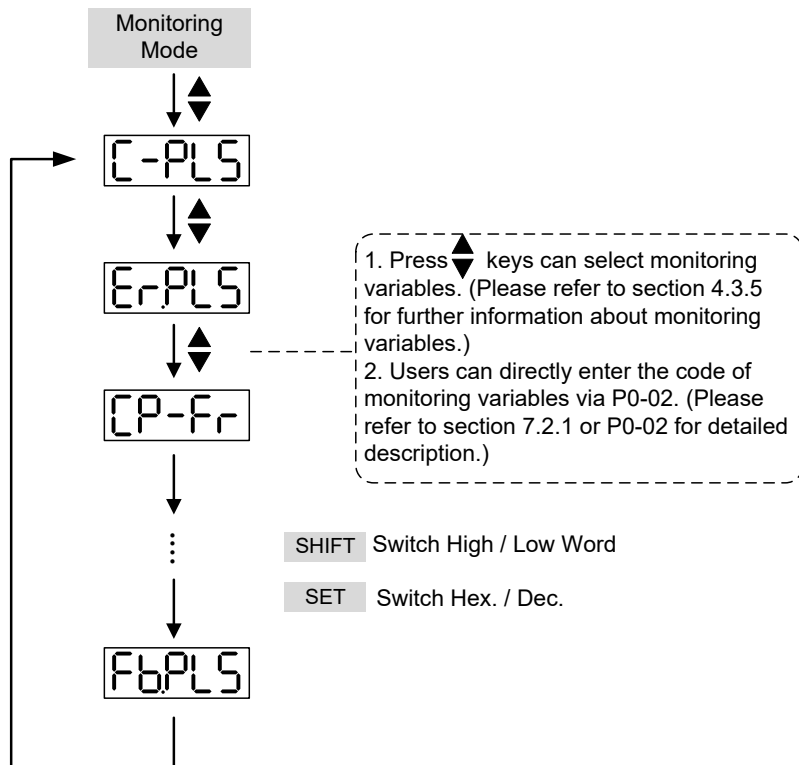

Parameter Mode

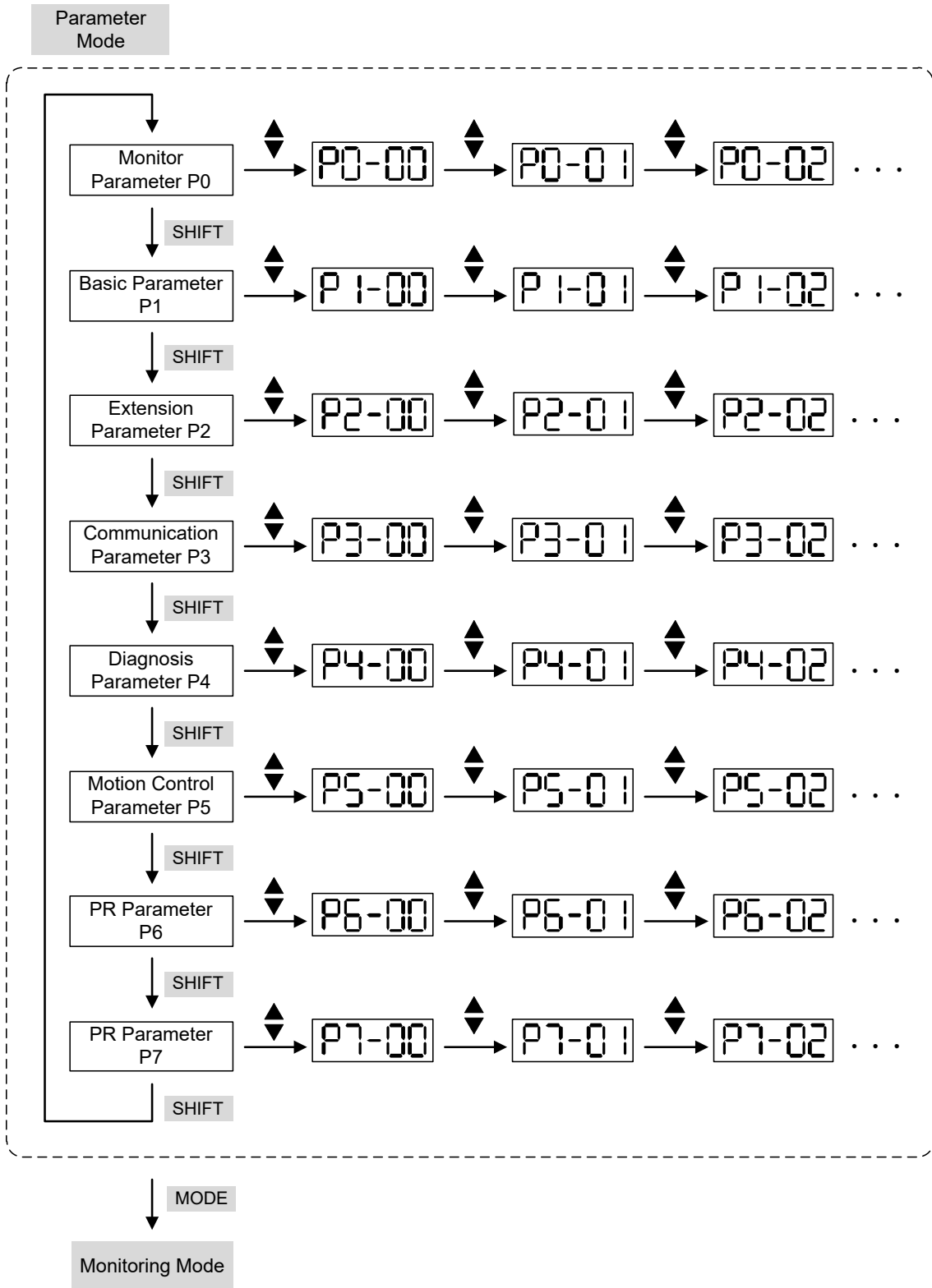

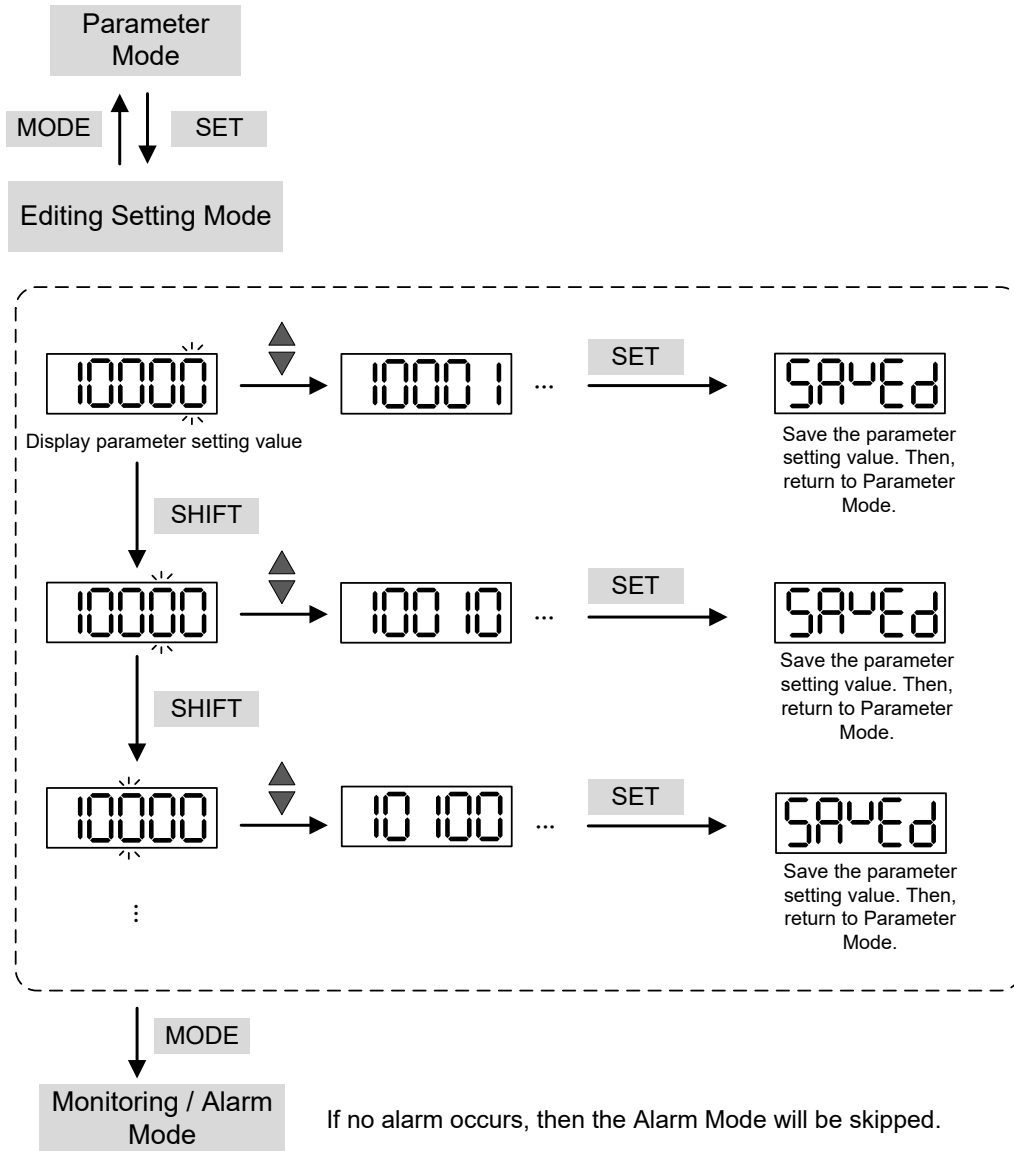

Edit Setting Mode



4.3 Status Display

4.3.1 Save Setting Display

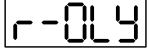
When finishing editing parameter, press the SET key to save the setting. The panel will display the setting status according to the setting for a second.

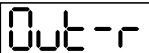
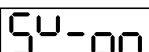
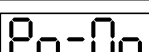
Displayed Symbol	Description
	The setting value is saved correctly. (Saved)
	Read-only parameter. Write-protected. (Read-Only)
	Enter the wrong password or no password has been entered. (Locked)
	Incorrect setting value or enter the reserved setting value. (Out of Range)
	No entering is allowed when it is Servo ON. (Servo On)
	Parameter will be effective after the servo drive is re-powered on. (Power On)

4.3.2 Decimal Point

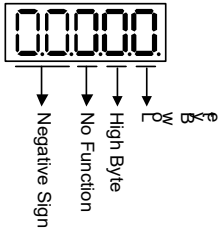
Display Symbol	Description
	<p>High byte / low byte indication: When the data is displayed in decimal 32 bits, it is for indicating the current high or low byte.</p> <p>Negative sign: When the data is displayed in decimal format, the two decimal points in the left represent the negative sign, no matter it is showed in 16 or 32 bits. When it is showed in hexadecimal format, it only shows positive sign.</p>

4.3.3 Alarm Message

Displayed Symbol	Description
	When there is an error of the drive, it will show 'AL' as the alarm sign and 'nnn' as the alarm code. For further explanation, please refer to Chapter 8, P0-01, parameter description, or Chapter 10, Troubleshooting.

4.3.4 Positive and Negative Sign Setting





Displayed Symbol	Description
	When entering the Editing Setting Mode, pressing the UP / DOWN keys can increase or decrease the displayed content. The SHIFT key can change the desired adjusted carry value. (The carry value is blinking at the moment.)
	Pressing the SHIFT key for two seconds can switch the positive (+) and negative (-) signs. If the parameter is over the range after switching the positive or negative sign, then it cannot be switched.

4.3.5 Monitor Display

When the power is applied to the drive, the display will show the monitor displayed symbol for a second, and then enter the Monitoring Mode. In Monitoring Mode, the UP / DOWN keys can change the desired monitor variable. Or, the user can directly change parameter P0-02 to set the monitor code. When applying to the power, the system will pre-set the monitor code according to the setting value of P0-02. For example, the setting value of P0-02 is 4. Every time when applying to the power, it will display C-PLS monitor sign first, and then shows the input pulse number of pulse command.

P0-02 Setting Value	Monitor Displayed Symbol	Description	Unit
0		Motor feedback pulse number (after the scaling of electronic gear ratio) (User unit)	[user unit]
1		Input pulse number of pulse command (after the scaling of electronic gear ratio) (User unit)	[user unit]
2		The difference of error pulse number between control command pulse and feedback pulse number (User unit)	[user unit]
3		Motor feedback pulse number (encoder unit) (1.28 million pulse/rev)	[pulse]
4		Input pulse number of pulse command (before the scaling of electronic gear ratio) (encoder unit)	[pulse]
5		Error pulse number (after the scaling of electronic gear ratio) (encoder unit)	[pulse]
6		Input frequency of pulse command	[Kpps]
7		Motor speed	[r/min]
8		Speed input command	[Volt]
9		Speed input command	[r/min]
10		Torque input command	[Volt]

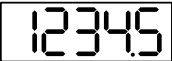
P0-02 Setting Value	Monitor Displayed Symbol	Description	Unit
11		Torque input command	[%]
12		Average torque	[%]
13		Peak torque	[%]
14		Main circuit voltage	[Volt]
15		Load / Motor inertia ratio (Note: If it shows 13.0, it means the actual inertia is 13)	[1 times]
16		IGBT temperature	[°C]
17		Resonance frequency (Low byte is the first resonance and high byte is the second one).	[Hz]
18	 	The absolute pulse number of encoder Z phase equals to the homing value, 0. It will be +5000 or -5000 pulse when rotating in forward or reverse direction.	-
19		Mapping parameter #1: shows the content of parameter P0-25 (specify the mapping target by P0-35)	-
20		Mapping parameter #2: shows the content of parameter P0-26 (specify the mapping target by P0-36)	-
21		Mapping parameter #3: shows the content of parameter P0-27 (specify the mapping target by P0-37)	-
22		Mapping parameter #4: shows the content of parameter P0-28 (specify the mapping target by P0-38)	-
23		Monitor variable #1: shows the content of parameter P0-09 (specify the monitor variable code by P0-17)	-
24		Monitor variable #2: shows the content of parameter P0-10 (specify the monitor variable code by P0-18)	-
25		Monitor variable #3: shows the content of parameter P0-11 (specify the monitor variable code by P0-19)	-
26		Monitor variable #4: shows the content of parameter P0-12 (specify the monitor variable code by P0-20)	-

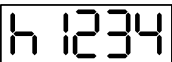
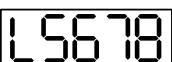
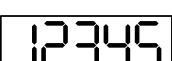
Example of the displayed value	Status Description	
 (Dec)	16 bits	If the value is 1234, it displays 01234 (shows in decimal format).
 (Hex)		If the value is 0x1234, it displays 1234 (shows in hexadecimal format; the first digit does not show any).
 (Dec high)  (Dec low)	32 bits	If the value is 1234567890, the display of the high byte is 1234.5 and displays 67890 as the low byte (shows in decimal format).
 (Hex high)  (Hex low)		If the value is 0x12345678, the display of the high byte is h1234 and displays L5678 as the low byte (shows in hexadecimal format).
	Negative display. If the value is -12345, it displays 1.2.345 (only shows in decimal format; there is no positive or negative sign for hexadecimal format display).	

Note:

1. Dec means it is displayed in decimal format. Hex means it is displayed in hexadecimal format.
2. The above display methods can be applied in Monitoring Mode and Editing Setting Mode.
3. When all monitor variables are 32 bits, high / low bit and the display (Dec / Hex) can be switched. According to the definition in Chapter 8, each parameter only supports one displaying method and cannot be switched.

4.4 General Function

4.4.1 Operation of Fault Record Display

When it is in Parameter Mode, select P4-00 ~ P4-04 and press the SET key, the corresponding fault record will be shown.

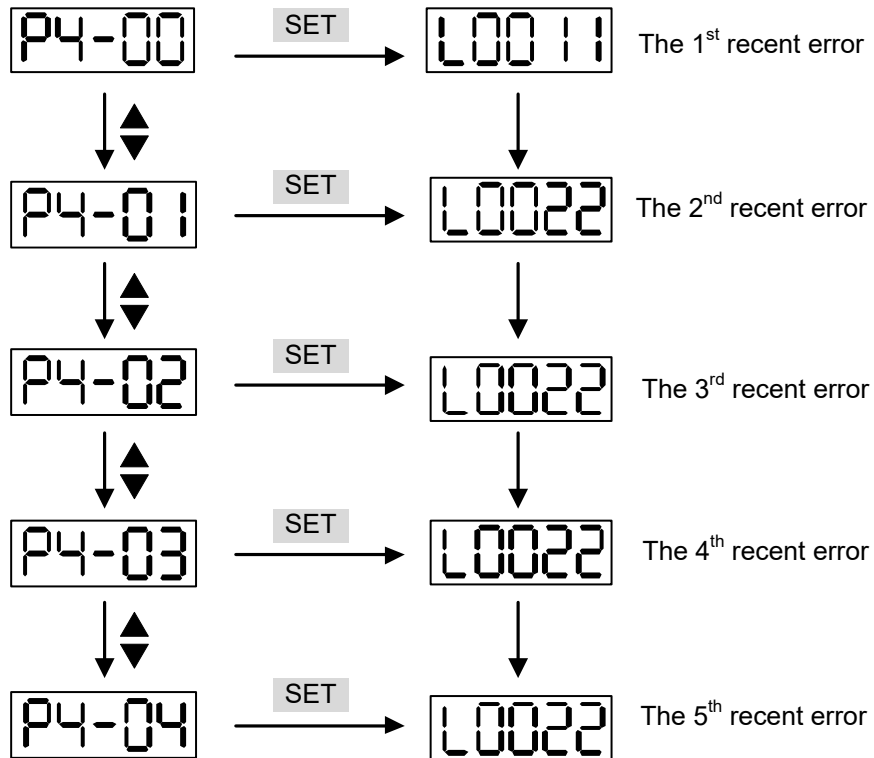

4.4.2 JOG Mode

When it is in Parameter Mode, select P4-05 and follow the setting method below for JOG operation (The communication mode does not support using the panel to set the JOG mode).

- (1) Press the SET key to display the speed value of JOG. The default value is 20 r/min.
- (2) Press the UP or DOWN key to adjust the desired speed value of JOG. It is adjusted to 100 r/min in the example.
- (3) Press the SET key to display JOG and enter JOG mode.
- (4) When it is in JOG Mode, press the UP or DOWN key to enable the servo motor in forward or reverse direction. The servo motor stops running as soon as the user stops pressing the key. JOG operation is working only when it is Servo ON.

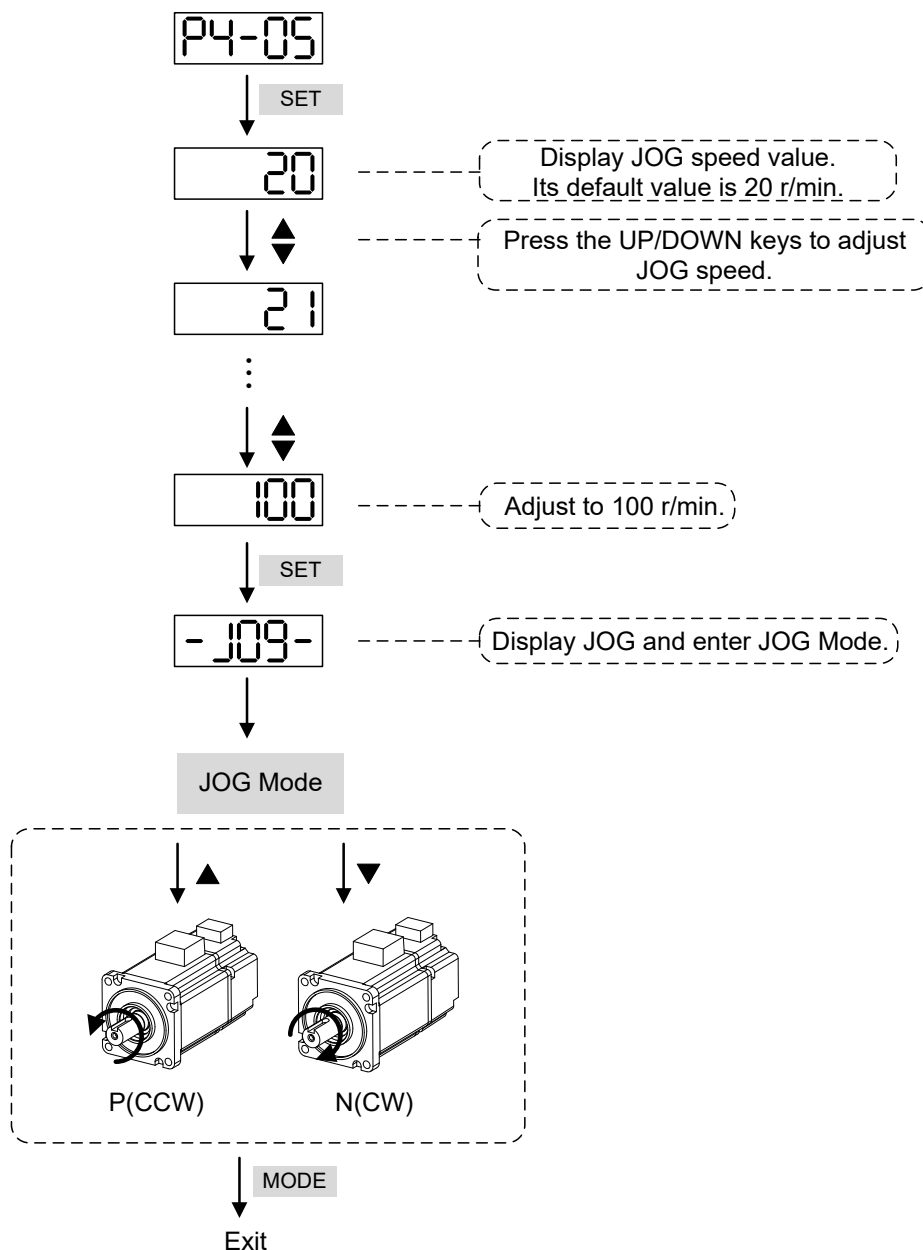

4.4.3 Force DO Output

Enter the Digital Output Mode by the following settings. Set P2-08 to 406 and enable the function of force DO mode. Then, set the force DO output by binary method via P4-06. When the setting value is 2, DO2 will be forced to enable. When the setting value is 5, DO1 and DO3 will be forced to enable. No data is retained in this mode. It returns to the normal DO mode when re-powering on the drive or setting P2-08 to 400.

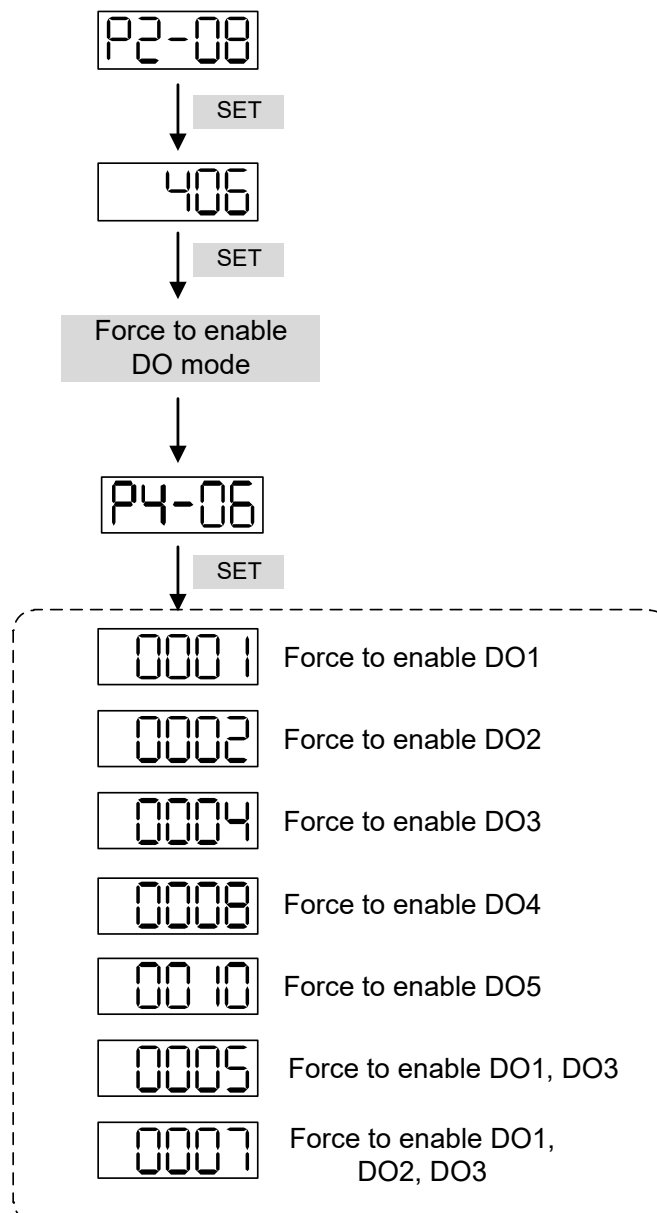

Note: P4-06 is displayed in hexadecimal format. Therefore, it will not show the fifth 0.

4.4.4 Digital Input Diagnosis Operation

Enter the Digital Input Diagnosis Mode by the following setting methods. When the external output signals DI1 ~ DI8 are ON, the corresponding signals will be shown on the panel. It is displayed by bit. When it shows bit, it means it is ON.

For example, if it shows **3FE1**, **E** is in hexadecimal format, it will be **1100** when it transfers to binary format. Then, DI6 ~ DI8 are ON.

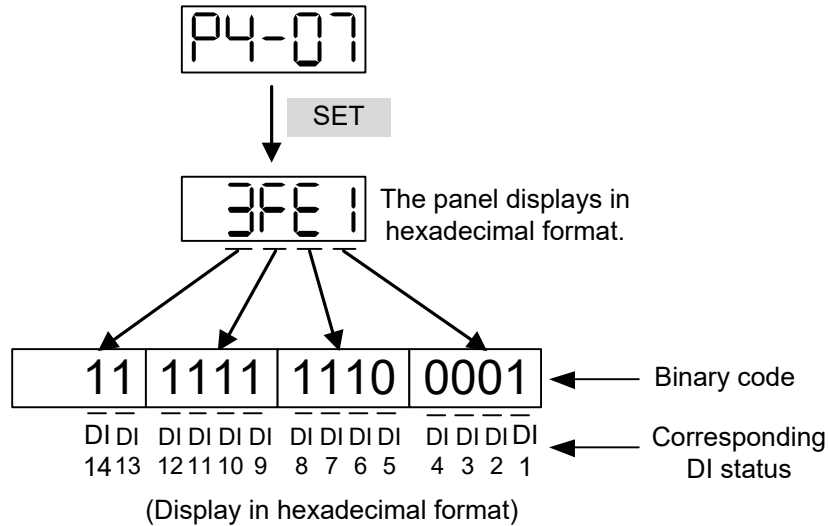

4.4.5 Digital Output Diagnosis Operation

Enter the Digital Output Diagnosis Mode by the following setting methods. The output signals DO1 ~ DO5 are ON and the corresponding signals will be shown on the panel. It is displayed by bit. When it shows bit, it means it is ON.

For example, if it shows **1F**, **F** is in hexadecimal format, it will be **1111** when it transfers to binary format. Then, DO1 ~ DO4 are ON.

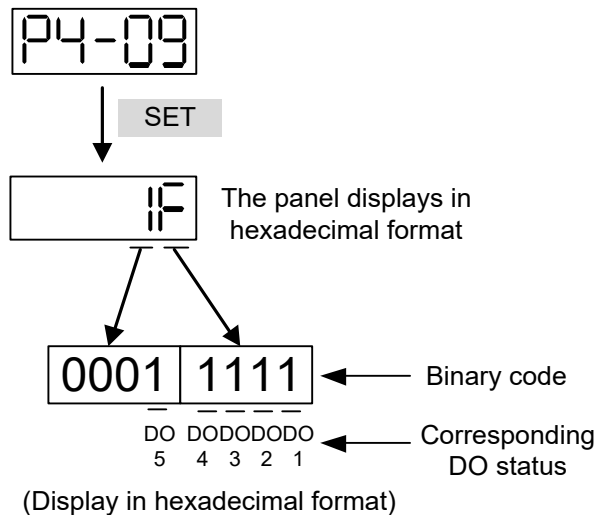

Chapter 5 Trial Operation and Tuning

This chapter is divided into two parts to describe the trial operation. The first one is the inspection without load and the other one is the inspection with load. For safety reasons, please conduct the first inspection.

5.1 Inspection without Load

Please remove the load of the servo motor, including coupling on the shaft and accessories, so as to avoid any damage to the servo drive or mechanism. This is aiming to avoid the falling off of the disassembled parts of the motor shaft which indirectly causes the personnel injury or equipment damage during operation. Running the motor without load, if the servo motor can run during normal operation, then it can connect to load for operation.

Caution: Please operate the servo motor without load first. If the servo motor runs normally, connect the load afterwards in order to avoid any danger.

Please check the following items before operation.

Inspection before operation (has not applied to the power yet)

- Check if there is any obvious damage on its appearance.
- The splicing parts of the wiring terminal should be isolated.
- Make sure the wiring is correct so as to avoid the damage or any abnormality.
- Check if the electrically conductive objects, including metal (such as screws) or inflammable objects, are not inside the servo drive.
- Check if the control switch is in OFF status.
- Do not place the servo drive or external regenerative resistor on inflammable objects.
- To avoid the electromagnetic brake losing efficacy, please check if stop function and circuit break function can work normally.
- If the peripheral devices are interfered by the electronic instruments, please reduce electromagnetic interference with devices.
- Please make sure the external voltage level of the servo drive is correct.

Inspection during operation (has already applied to the power)

- The encoder cable should avoid excessive stress. When the motor is running, make sure the cable is not worn or stretched.
- Please contact Delta if there is any vibration of the servo motor or unusual noise during the operation.
- Make sure the setting of the parameters is correct. Different machinery has different characteristic, so please adjust the parameter according to the characteristic of each machinery.
- Please reset the parameter when the servo drive is in SERVO OFF status, or it may cause malfunction.
- When the relay is operating, if there is no contact noise or there is other abnormal noise, contact Delta.
- Check if the power indicator and LED display work normally.

5.2 Applying Power to the Servo Drive

Please follow the instructions below.

A. Make sure the wiring between the motor and servo drive is correct.

- 1) U, V, W, and FG have to connect to the red, white, black, and green wires respectively. If the wiring is incorrect, the motor cannot work normally. The ground wire FG of the motor must be connected to the ground terminal of the servo drive. Please refer to sections 3.1 and 3.2 for wiring.
- 2) The encoder cable of the motor has correctly connected to CN2: If users only desire to execute JOG function, it is unnecessary to connect CN1 and CN3 (Please refer to Chapter 5.3). Refer to sections 3.1 and 3.5 for the wiring of CN2.

Caution: Do not connect the power terminal (R, S, T) to the output terminal (U, V, W) of the servo drive. Or it might damage the servo drive.

B. Power circuit of the servo drive:

Caution: Wiring of 220V servo drive is different from that of 400V. Make sure the wiring is correct, or it might damage the servo drive.

220V Servo Drive: Apply power to the servo drive. Please refer to section 3.1.3 for power wiring.

400V Servo Drive: Apply power to the servo drive. Please refer to section 3.2.3 for power wiring.

C. Power on:

220V Servo Drive: Power of the servo drive: including control circuit (L_{1C}, L_{2C}) and main circuit (R, S, T) power.

400V Servo Drive: Power of the servo drive: including control circuit (DC24V, DC0V) and main circuit (R, S, T) power.

When the power is on, the display of the servo drive will be:

AL013

The digital inputs (DI6 ~ DI8) of the default value are the signals of negative limit error (NL), positive limit error (PL), and emergency stop (EMGS), if not using the default setting of DI6 ~ DI8, adjusting the setting of P2-15 ~ P2-17 is a must. Parameters could be set to 0 (disable this DI function) or modified to another function.

From the last setting, the servo drive status displays parameter P0-02 setting as the motor speed (07), then the screen display will be:

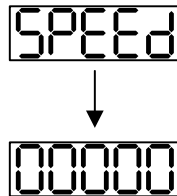

When the screen displays no text, please check if the power of control circuit is under voltage.

1) When the screen displays:

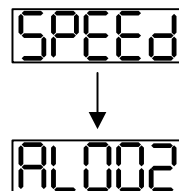

Warning of overvoltage:

It means the voltage input by the main circuit is higher than the rated voltage or power input error (incorrect power system).

Corrective action:

- Use the voltmeter to measure if the input voltage from the main circuit is within the range of rated voltage value.
- Use the voltmeter to measure if the power system complies with the specification.

2) When the screen displays:

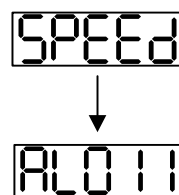

Warning of encoder error:

Check if the motor encoder is securely connected or the wiring is correct.

Corrective action:

- Check if the wiring is the same as the instruction of the user manual.
- Check the encoder connector.
- Check if the wiring is loose.
- Check if the encoder is damaged.

3) When the screen displays:

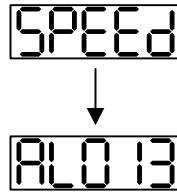

Warning of emergency stop:

Please check if any of the digital inputs DI1 ~ DI8 is set to emergency stop (EMGS).

Corrective action:

- If not desiring to set emergency stop (EMGS) as one of the digital input, make sure no digital input is set to emergency stop (EMGS) among DI1 ~ DI8. (That is to say none of the parameters, P2-10 ~ P2-17, is set to 21.)
- If the function of emergency stop (EMGS) is needed and this DI is set as normally close (function code: 0x0021), please make sure this DI is always normally close. If not, please set this DI as normally open (function code: 0x0121).

4) When the screen displays:

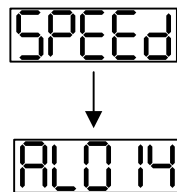

Warning of negative limit error:

Please check if any of the digital inputs DI1 ~ DI8 is set to negative limit (NL) and that DI is ON.

Corrective action:

- If not desiring to set negative limit (NL) as one of the digital input, make sure no digital input is set to negative limit (NL) among DI1 ~ DI8. (That is to say none of the parameters, P2-10 ~ P2-17, is set to 22.)
- If the function of negative limit (NL) is needed and this DI is set as normally close (function code: 0x0022), please make sure this DI is always normally close. If not, please set this DI as normally open (function code: 0x0122).

5) When the screen displays:

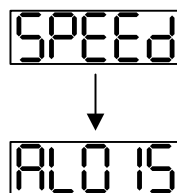

Warning of positive limit error:

Please check if any of the digital inputs DI1 ~ DI8 is set positive limit (PL) and that DI is ON.

Corrective action:

- If not desiring to set positive limit (PL) as one of the digital input, make sure no digital input is set to positive limit (PL) among DI1 ~ DI8. (That is to say none of the parameters, P2-10 ~ P2-17, is set to 23.)
- If the function of positive limit (PL) is needed and this DI is set as normally close (function code: 0x0023), please make sure this DI is always normally close. If not,

please set this DI as normally open (function code: 0x0123).

6) When the screen displays:

A digital display showing the alphanumeric code 'AL001' in a seven-segment font.

Warning of overcurrent:

Corrective Action:

- Check the connection between the motor and servo drive.
- Check if the conducting wire is short-circuited. Exclude short circuit and avoid metal conductors being exposed.

7) When the screen displays:

A digital display showing the alphanumeric code 'AL003' in a seven-segment font.

Warning of undervoltage:

Corrective action:

- Check if the wiring of main circuit input voltage is correct.
- Use the voltmeter to measure if the main circuit voltage is normal.
- Use the voltmeter to measure if the power system complies with the specification.

Note: During the process of power on or servo on, if an alarm occurs or shows any abnormal display, please contact the distributors.

5.3 JOG Trial Run without Load

It is very convenient to test the motor and servo drive with the method of JOG trial run without load since the extra wiring is unnecessary. For safety reasons, it is recommended to set JOG at low speed. Please see the following descriptions.

Step 1: Use the software to set the drive to Servo ON by setting parameter P2-30 to 1. This setting is to force the servo ON through software.

Step 2: Set P4-05 as JOG speed (Unit: r/min). After setting the desired JOG speed, press the **SET** key, and the servo drive will enter JOG mode.

Step 3: Press the **MODE** key to exist JOG mode.

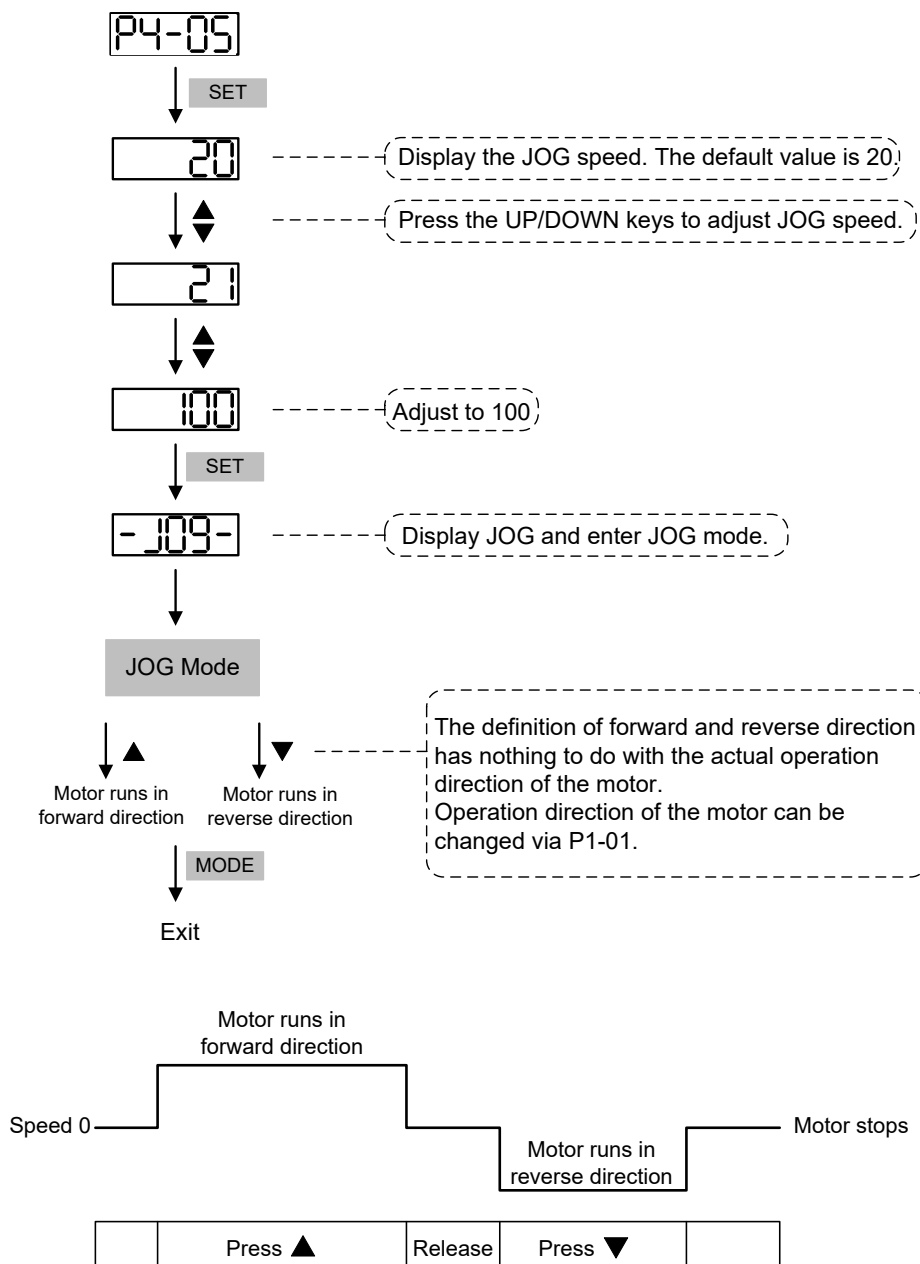

If the motor does not run, please check if the wiring between UVW and encoder cable is correct.
 If the motor runs abnormally, please check if the UVW phase sequence is correct.

5.4 Trial Run without Load (Speed Mode)

Before the trial run without load, firmly secure the motor base so as to avoid the danger caused by the reaction of motor operation.

Step 1:

Set the control mode of the servo drive to speed mode. Set P1-01 to 2 as speed mode. Then, cycle power on the servo drive.

Step 2:

In speed control mode, the digital input settings of trial run are as follows:

Digital Input	Parameter Setting Value	Symbol	Function Description	CN1 Pin No.
DI1	P2-10 = 101	SON	Servo ON	DI1- = 9
DI2	P2-11 = 109	TRQLM	Torque limit	DI2- = 10
DI3	P2-12 = 114	SPD0	Speed command selection	DI3- = 34
DI4	P2-13 = 115	SPD1	Speed command selection	DI4- = 8
DI5	P2-14 = 102	ARST	Alarm reset	DI5- = 33
DI6	P2-15 = 0	Disabled	Invalid DI function	-
DI7	P2-16 = 0	Disabled	Invalid DI function	-
DI8	P2-17 = 0	Disabled	Invalid DI function	-
EDI9	P2-36 = 0	Disabled	Invalid DI function	CN7 = 2
EDI10	P2-37 = 0	Disabled	Invalid DI function	CN7 = 3
EDI11	P2-38 = 0	Disabled	Invalid DI function	CN7 = 4
EDI12	P2-39 = 0	Disabled	Invalid DI function	CN7 = 5
EDI13	P2-40 = 0	Disabled	Invalid DI function	CN7 = 6
EDI14	P2-41 = 0	Disabled	Invalid DI function	CN7 = 7

The above table disables the functions of negative limit (DI6), positive limit (DI7), and emergency stop (DI8). Thus, the values of parameters P2-15 ~ P2-17 and P2-36 ~ P2-41 are set to 0 (Disabled). The digital input of Delta's servo drive can be programmed by users. When programming digital input, please refer to the description of DI code.

The default setting includes the functions of negative limit, positive limit, and emergency stop. Therefore, after the setting is complete, if any alarm occurs, please cycle power on the servo drive or switch ON DI5 to clear the alarm. Please refer to section 5.2.

The speed command selection is determined by SPD0 and SPD1. See the table below.

Speed Command No.	DI signal of CN1		Command Source	Content	Range
	SPD1	SPD0			
S1	0	0	External analog command	Voltage difference between V-REF and GND	-10V ~ +10V
S2	0	1	Register parameter	P1-09	-60000 ~ 60000
S3	1	0		P1-10	-60000 ~ 60000
S4	1	1		P1-11	-60000 ~ 60000

0: means DI is OFF; 1: means DI is ON

Register parameter

The parameter setting range is from -60000 to 60000.

Setting speed = Setting range x unit (0.1 r/min).

For example: P1-09 = +30000; Setting speed = +30000 x 0.1 r/min = +3000 r/min

Command setting of speed register

Set parameter P1-09 to 30000.

Set parameter P1-10 to 1000.

Set parameter P1-11 to -30000.

Input command	Rotation direction
+	CW
-	CCW

Step 3:

- (1) Users switch ON DI1 and Servo ON.
- (2) Both DI3 (SPD0) and DI4 (SPD1), the speed command, are OFF, which means it currently executes S1 command. The motor rotates according to analog voltage command.
- (3) When DI3 (SPD0) is ON, it means it currently executes S2 command (3000 r/min). The rotation speed is 3000 r/min.
- (4) When DI4 (SPD1) is ON, it means it currently executes S3 command (100 r/min). The rotation speed is 100 r/min.
- (5) When both DI3 (SPD0) and DI4 (SPD1) are ON, it means it currently executes S4 command (-3000 r/min). The rotation speed is -3000 r/min.
- (6) Steps (3), (4), and (5) can be repeatedly executed.
- (7) If users desire to stop the motor, switch OFF DI1 (Servo OFF).

5.5 Trial Run without Load (Position Mode)

Before the trial run without load, firmly secure the motor base so as to avoid the danger caused by the reaction of motor operation.

Step 1:

Set the control mode of the servo drive to position (PR) mode.

Set parameter P1-01 to 1 as position (PR) mode. Then, cycle power on the servo drive.

Step 2: In position mode, the digital input settings of trial run are as follows:

Digital Input	Parameter Setting Value	Symbol	Function Description	CN1 Pin No.
DI1	P2-10 = 101	SON	Servo ON	DI1- = 9
DI2	P2-11 = 108	CTRG	Command triggered	DI2- = 10
DI3	P2-12 = 111	POS0	Position command selection	DI3- = 34
DI4	P2-13 = 112	POS1	Position command selection	DI4- = 8
DI5	P2-14 = 102	ARST	Alarm reset	DI5- = 33
DI6	P2-15 = 0	Disabled	Invalid DI function	-
DI7	P2-16 = 0	Disabled	Invalid DI function	-
DI8	P2-17 = 0	Disabled	Invalid DI function	-
EDI9	P2-36 = 0	Disabled	Invalid DI function	CN7 = 2
EDI10	P2-37 = 0	Disabled	Invalid DI function	CN7 = 3
EDI11	P2-38 = 0	Disabled	Invalid DI function	CN7 = 4
EDI12	P2-39 = 0	Disabled	Invalid DI function	CN7 = 5
EDI13	P2-40 = 0	Disabled	Invalid DI function	CN7 = 6
EDI14	P2-41 = 0	Disabled	Invalid DI function	CN7 = 7

The above table disables the functions of negative limit (DI6), positive limit (DI7), and emergency stop (DI8), thus, set P2-15 ~ P2-17 and P2-36 ~ P2-41 to 0 (Disabled). The digital input of Delta's servo drive can be programmed by users. When programming digital input, please refer to the description of DI code.

The default setting includes the functions of negative limit, positive limit, and emergency stop. Therefore, after the setting is complete, if any alarm occurs, please cycle power on the servo drive or switch ON DI5 to clear the alarm. Please refer to section 5.2.

Please refer to section 3.12.2, Position (PR) Mode Standard Wiring for wiring diagram. However, since POS2 is not the default digital input, set P2-14 to 113. Please refer to the table below for 64 sets of register command, POS0 ~ POS5, and the relative parameters.

Position Command	POS5	POS4	POS3	POS2	POS1	POS0	CTRG	Corresponding Parameter
PR0	0	0	0	0	0	0	↑	P6-00
								P6-01
PR1	0	0	0	0	0	1	↑	P6-02
								P6-03
~								~
PR50	1	1	0	0	1	0	↑	P6-98
								P6-99
PR51	1	1	0	0	1	1	↑	P7-00
								P7-01
~								~
PR64	1	1	1	1	1	1	↑	P7-26
								P7-27

0: means DI is OFF; 1: means DI is ON

Users can set the 64-set of command value (P6-00 ~ P7-27). The value can be set as the absolute position command.

5.6 Tuning Procedure

Estimate the inertia ratio: JOG Mode

Tuning Procedure	Display
1. After completing wiring, when applying to the power, the servo drive will display:	AL0 13
2. Press the MODE Key to select the mode of parameter function.	P0-00
3. Press the SHIFT Key twice to select the mode of parameter group.	P2-00
4. Press the UP Key to select parameter P2-17.	P2-17
5. Press the SET Key to display parameter value, which is shown as the content on the right.	21
6. Press the SHIFT Key twice, then press the UP Key and then press the SET Key.	121
7. Press the UP Key to select parameter P2-30.	P2-30
8. Press the SET Key to display the parameter value.	0
9. Press the UP Key and select the parameter value 1.	1
10. Then, the servo drive is ON and will show:	0
11. Press the DOWN Key thrice to select the value of inertia ratio.	JL
12. The panel displays the current value of inertia ratio (default value).	10
13. Press the MODE Key to select the mode of parameter function.	P2-30
14. Press the SHIFT Key twice to select the mode of parameter group.	P4-00
15. Press the UP Key to select parameter P4-05.	P4-05
16. Press the SET Key to show the content, which is 20 r/min at JOG speed. Press the UP or DOWN Key to increase or decrease the JOG speed. Press the SHIFT Key to move to the next digit of the left.	20 ↓ 200
17. Set the desired JOG speed and press the SET Key which is shown as the figure on the right.	-JOG-
18. Press the UP Key to rotate the motor in forward direction while press the DOWN Key the motor will rotate in reverse direction.	
19. Execute JOG operation at low speed first. With the constant speed, if the motor operates smoothly in forward and reverse directions, users can execute JOG operation at higher speed.	
20. In P4-05, the servo drive cannot display inertia ratio. Please press the MODE Key twice to view the value of inertia ratio. If users desire to execute JOG operation again, press the MODE Key, and then press the SET Key twice. Observe the panel display to see if the load inertia ratio / total weight of movable section and load remain at the same value after acceleration and deceleration.	

5.6.1 Flowchart of Tuning Procedure

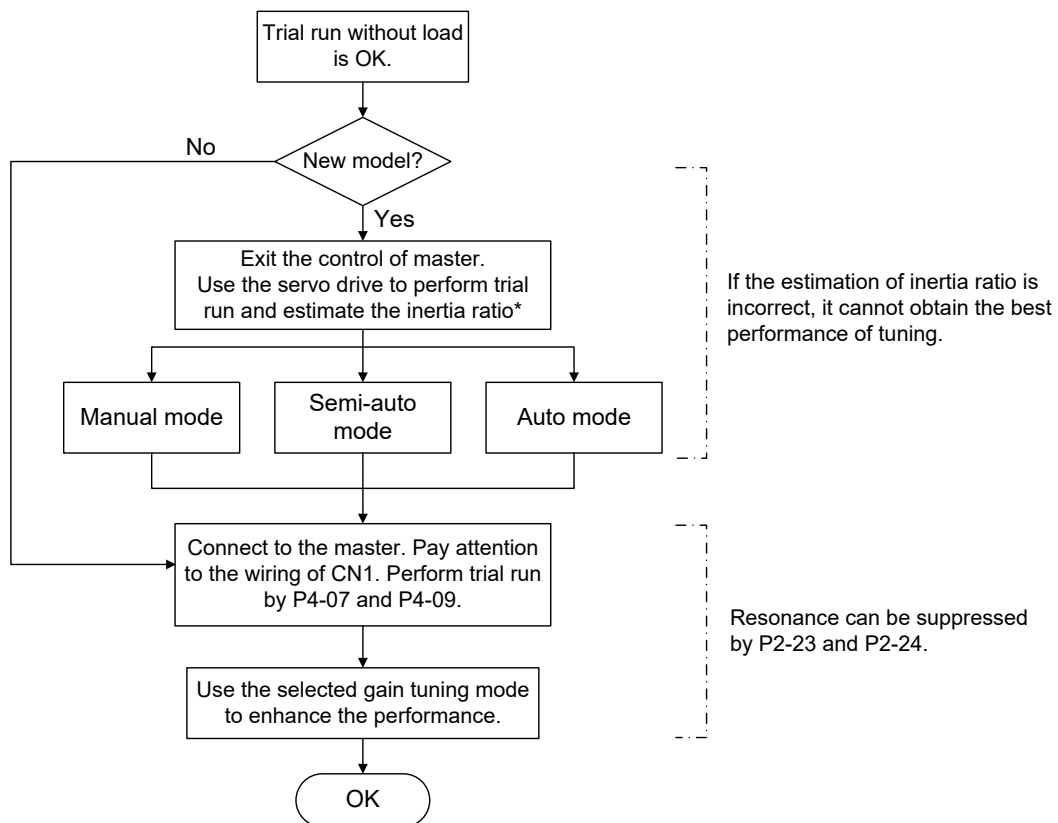

* refers to "the inertia ratio" for rotary motors or "the total weight (kg) of the coil assembly, magnetic way, and load" for linear motors.

5.6.2 Inertia Estimation Flowchart (with Mechanism)

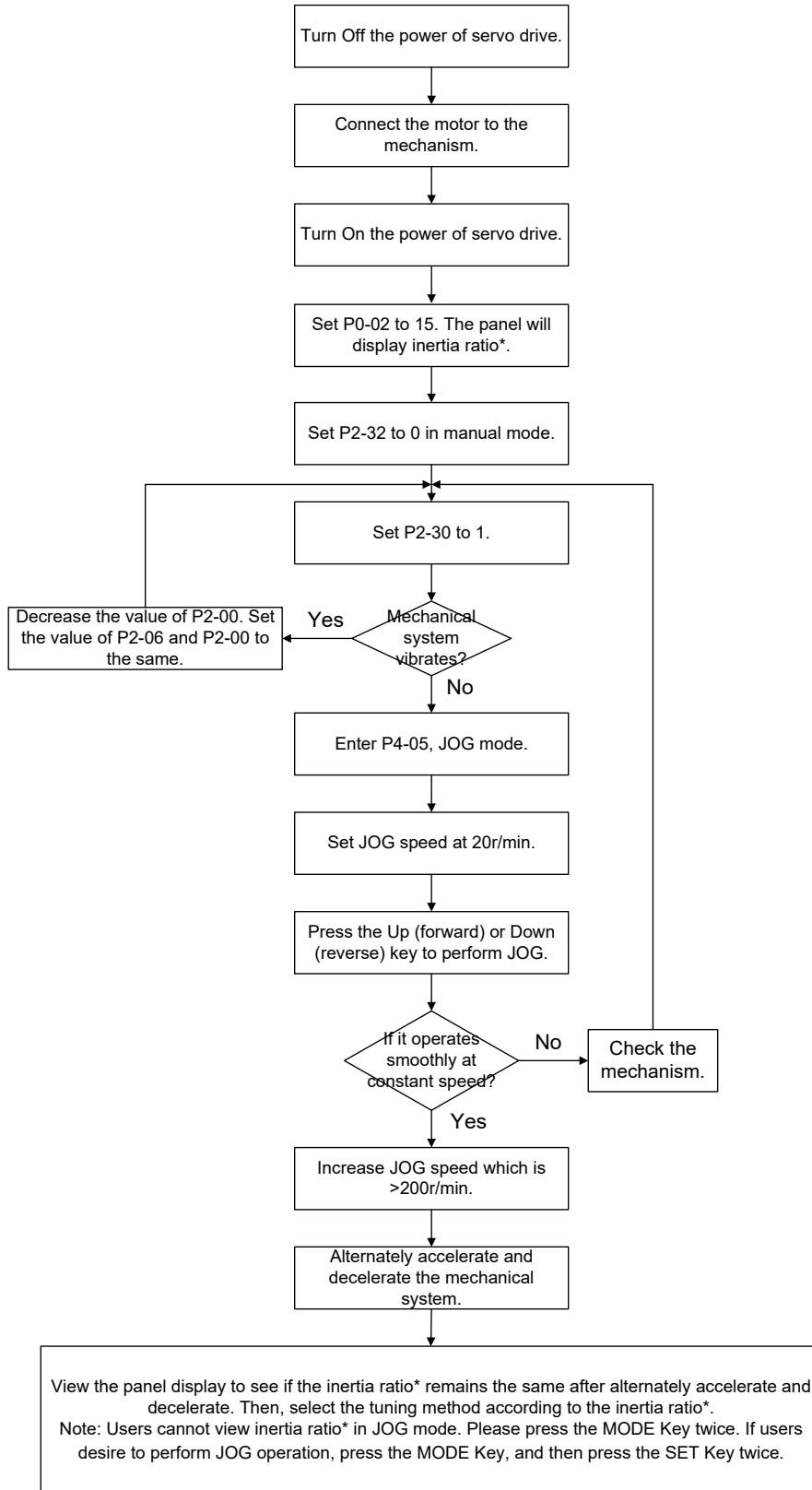

* refers to "the inertia ratio" for rotary motors or "the total weight (kg) of the coil assembly, magnetic way, and load" for linear motors.

5.6.3 Flowchart of Auto Tuning

Set P2-32 to 1 (auto mode, continuous tuning)

Continue to estimate the system inertia. Automatically save the value in P1-37 every 30 minutes and refer the stiffness and bandwidth setting of P2-31.

P2-31 Stiffness setting in auto tuning mode (The default value is 80)

In auto and semi-auto modes, the bandwidth setting of speed circuit is:

1 ~ 50 Hz: low-stiffness, low-response

51 ~ 250 Hz: medium-stiffness, medium-response

251 ~ 850 Hz: high-stiffness, high-response

851 ~ 1000 Hz: extremely high-stiffness, extremely high-response

Stiffness setting in auto tuning mode: the bigger the value is, the stronger the stiffness will be.

Adjust the value of P2-31: Increase the value of P2-31 to increase stiffness or decrease to reduce the noise. Continue to tune until the performance is satisfied. Then, tuning is complete.

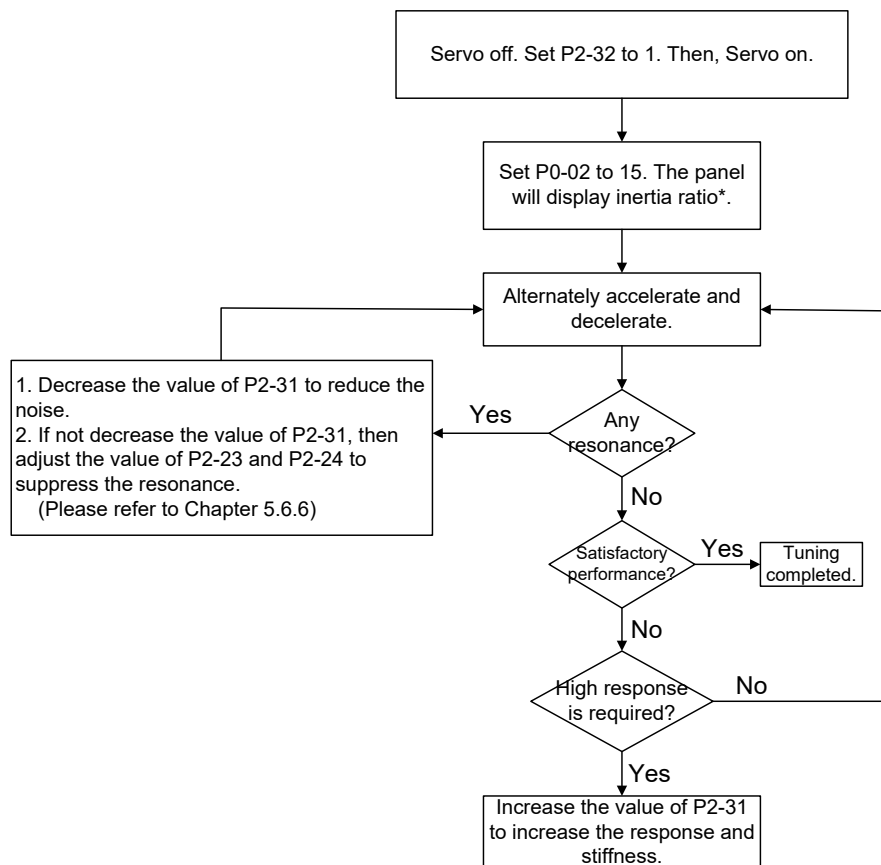

* refers to “the inertia ratio” for rotary motors or “the total weight (kg) of the coil assembly, magnetic way, and load” for linear motors.

5.6.4 Flowchart of Semi-Auto Tuning

Set P2-32 to 2 (semi-auto mode, non-continuous tuning)

After tuning for a while and wait until the system inertia is stable, it stops estimating. The estimated inertia ratio will be saved to P1-37. When switching the mode from manual or auto to semi auto, the system starts tuning again. During the process of estimation, the system will refer the stiffness and bandwidth setting of P2-31.

P2-31 Response setting in auto mode (The default value is 80)

In auto and semi-auto modes, the bandwidth setting of speed circuit is:

1 ~ 50 Hz: low-stiffness, low-response

51 ~ 250 Hz: medium-stiffness, medium-response

251 ~ 850 Hz: high-stiffness, high-response

851 ~ 1000 Hz: extremely high-stiffness, extremely high-response

Response setting in semi-auto tuning mode: the bigger the value is, the better the response will be.

Adjust the value of P2-31: Increase the value of P2-31 to increase the response or decrease to reduce the noise. Continue to tune until the performance is satisfied. Then, tuning is complete.

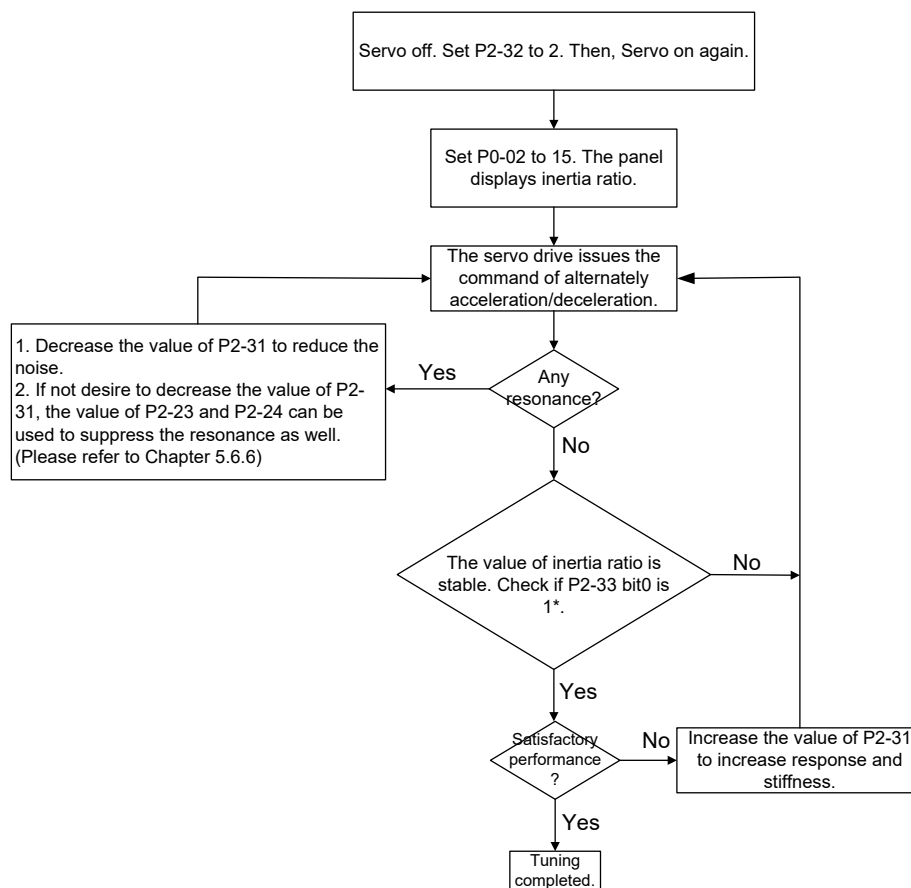

Note:

1. If P2-33 bit 0 is set to 1, it means the inertia estimation in semi-auto mode is completed. The result can be accessed by P1-37.
2. If the value of P2-33 bit 0 is cleared to 0, the system will start to estimate again.

5.6.5 Limit of Inertia Ratio

Acceleration / Deceleration time of reaching 2000 r/min should be less than 1 second.

The speed in forward and reverse directions should be higher than 200 r/min.

The load inertia should be under 100 times of motor inertia.

The change of external force of inertia ratio cannot be too severe.

In auto mode, the inertia value will be saved to P1-37 every 30 minutes; while in semi-auto mode, the inertia value will be saved to P1-37 only until the system inertia is stable and stops the estimation of load inertia.

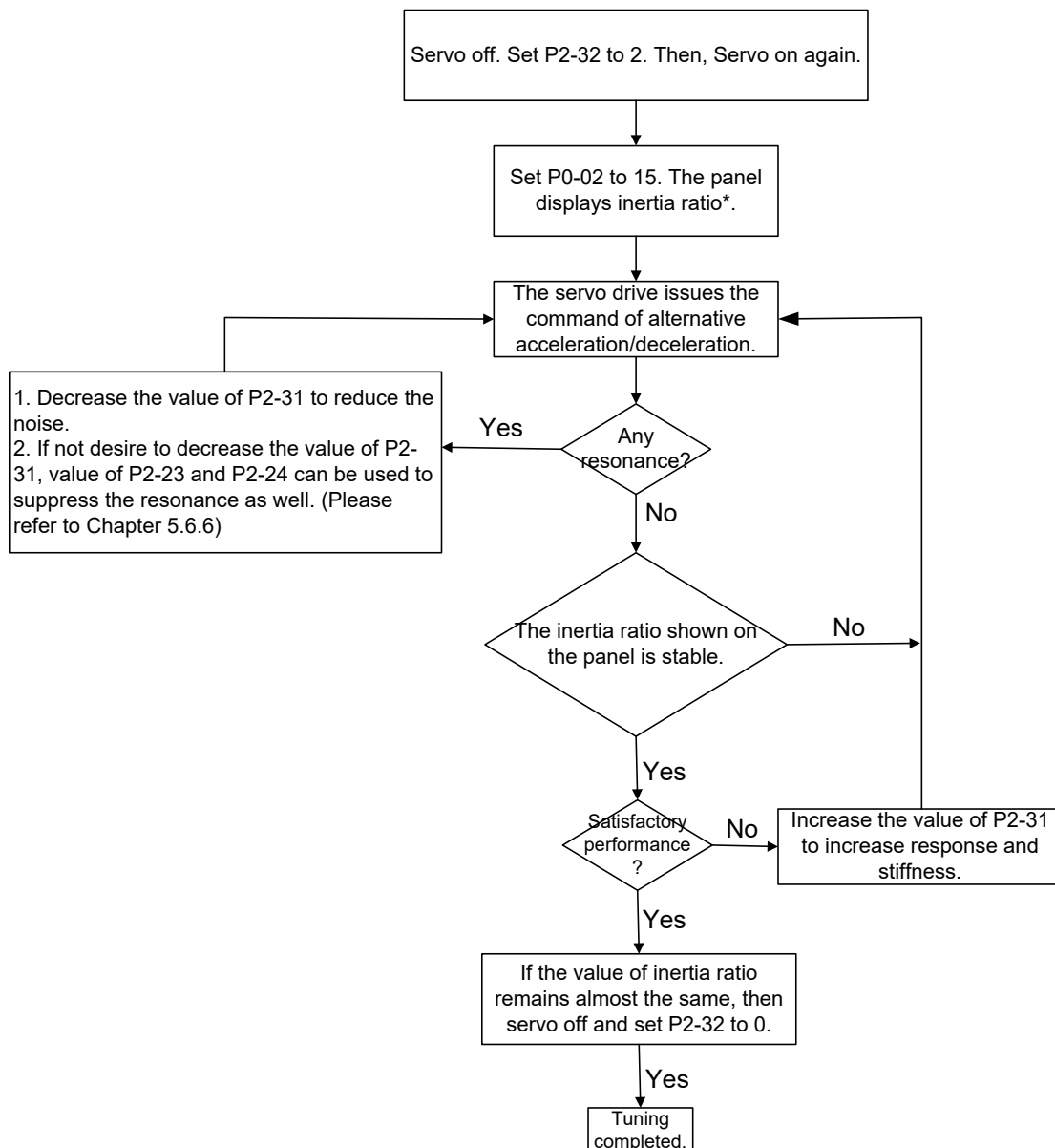

5.6.6 Mechanical Resonance Suppression Method

Three groups of Notch filter are provided to suppress mechanical resonance. Two of them can be set to the auto resonance suppression and manual adjustment.

The procedure of manually suppressing the resonance is as the followings:

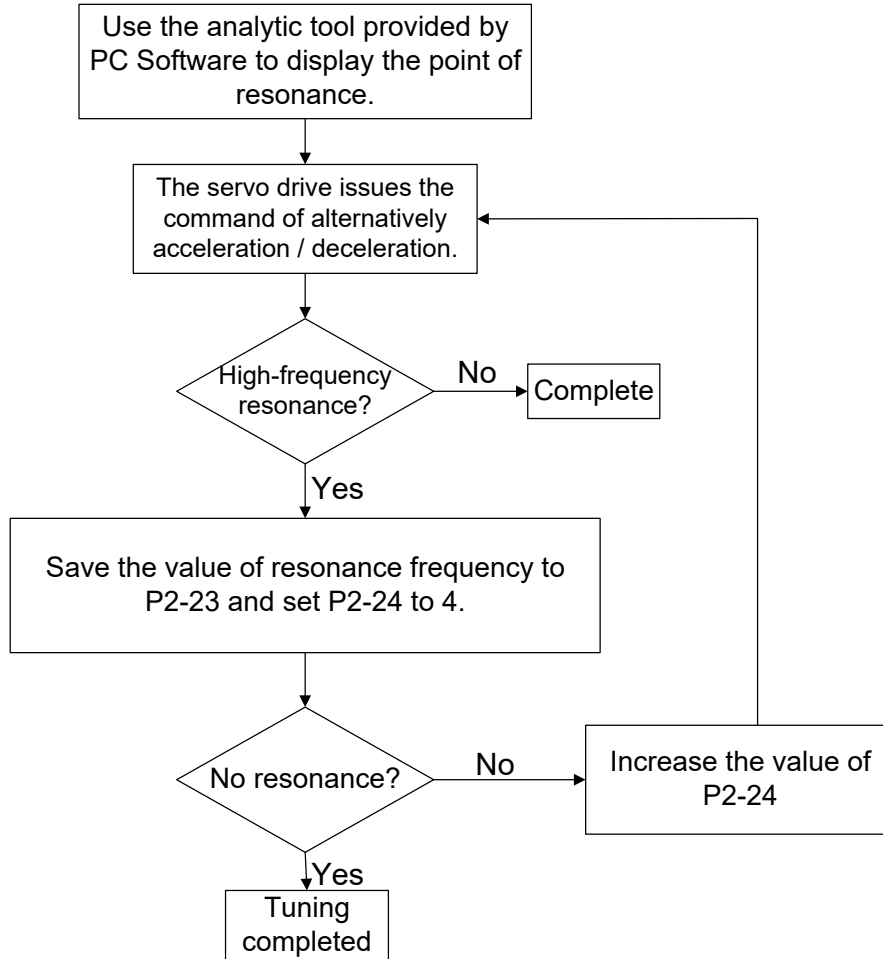

The procedure of the auto resonance suppression is as the followings:

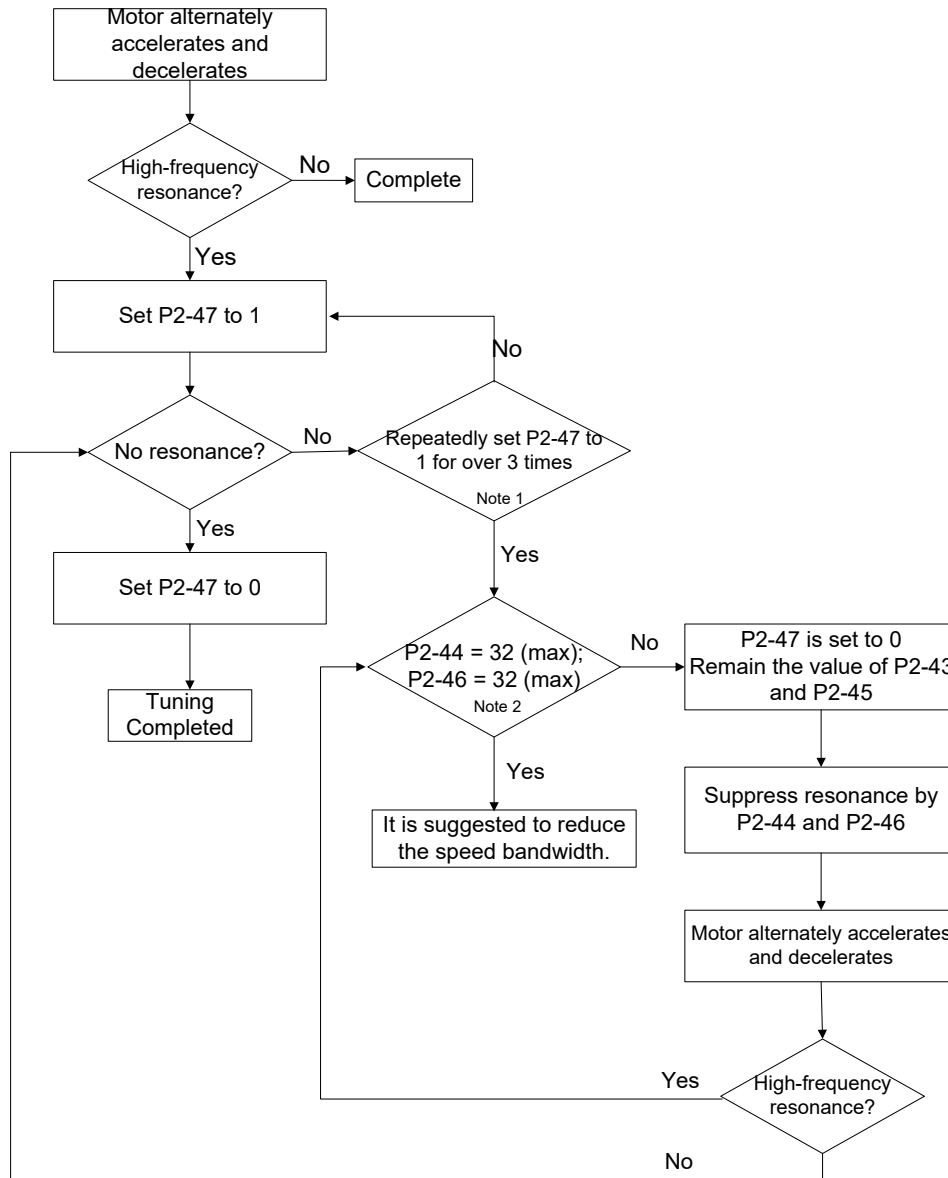

Note:

- Parameters P2-44 and P2-46 are the setting values of resonance suppression. If you have set to the maximum (32dB) and cannot suppress the resonance, please reduce the speed bandwidth. After setting P2-47, you can check the values of P2-44 and P2-46. If the value of P2-44 is not 0, it means there is a resonance frequency in the system. Then, you can access P2-43 to see the resonance frequency (Hz). When there is another resonance frequency, the information will be shown in P2-45 and P2-46.
- If resonance still occurs, after you set P2-47 to 1 for 3 times, please manually adjust the setting of resonance.

5.6.7 Tuning Mode and Parameters

Tuning mode	P2-32	Auto-set parameters	User-defined parameters	Inertia adjustment
Manual mode	0 (default setting)	N/A	P1-37 (Inertia ratio of the motor) P2-00 (Position control gain) P2-04 (Speed control gain) P2-06 (Speed integral compensation) P2-25 (Low-pass filter of resonance suppression) P2-26 (Anti-interference gain)	The value remains
Auto mode (continuous estimation)	1	P1-37 P2-00 P2-04 P2-06 P2-25 P2-26 P2-49	P2-31 Frequency response of speed loop setting in auto mode (response level)	Continuous tuning (update the inertia every 30 minutes)
Semi-auto mode (non-continuous estimation)	2	P1-37 P2-00 P2-04 P2-06 P2-25 P2-26 P2-49	P2-31 Frequency response of speed loop setting in semi-auto mode (response level)	Non-continuous tuning (stop updating the inertia after operating for a while)

When switching the mode from auto mode 1 to manual mode 0, the values of P1-37, P2-00, P2-04, P2-06, P2-25, P2-26, and P2-49 will be modified to the ones in auto mode.

When switching the mode from semi-auto mode 2 to manual mode 0, the values of P1-37, P2-00, P2-04, P2-06, P2-25, P2-26, and P2-49 will be modified to the ones in semi-auto mode.

5.6.8 Tuning in Manual Mode

The selection of position or speed response bandwidth should be determined by the machinery stiffness and applications. Generally speaking, machines that require high-frequency positioning or high precision need higher response bandwidth. However, it might easily cause the resonance. And the machinery with higher stiffness is needed to avoid the resonance. When using the unknown response bandwidth machinery, users could gradually increase the gain setting value to increase the response bandwidth. Then, decrease the gain setting value until the resonance exists. The followings are the related descriptions of gain adjustment.

- Position control gain (KPP, parameter P2-00)

This parameter determines the response of position loop. The bigger KPP value will cause the higher response bandwidth of position loop. And it will cause better following error, smaller position error, and shorter settling time. However, if the value is set too high, the machinery will vibrate or overshoot when positioning. The calculation of position loop response bandwidth is as the following:

$$\text{Response bandwidth of position loop (Hz)} = \frac{KPP}{2\pi}$$

- Speed control gain (KVP, parameter P2-04)

This parameter determines the response of speed loop. The higher KVP value will cause the higher response bandwidth of speed loop and better following error. However, if the value is set too high, it would easily cause machinery resonance. The response bandwidth of speed loop must be 4 ~ 6 times higher than the response bandwidth of position loop. Otherwise, the machinery might vibrate or overshoot when positioning. The calculation of speed loop response bandwidth is as the following:

$$\text{Response bandwidth of speed loop (Hz)} = \left(\frac{KVP}{2\pi} \right) \times \left[\frac{(1+P1-37/10)}{(1+JL/JM)} \right]$$

JM: Motor Inertia; JL: Load Inertia; P1-37: 0.1 times

When P1-37 (estimation or setting) equals the real inertia ratio (JL/JM), the real speed loop response bandwidth will be:

$$\text{Response bandwidth of speed loop (Hz)} = \left(\frac{KVP}{2\pi} \right) \times \left[\frac{(1 + P1.037/10)}{(1 + JL/JM)} \right]$$

- Speed integral compensation (KVI, parameter P2-06)

The higher the KVI value is, the better the capability of eliminating the deviation will be. However, if the value is set too big, it might easily cause the vibration of machinery. It is suggested to set the value as the following:

$$KVI \leq 1.5 \times \text{Response bandwidth of speed loop (Hz)}$$

- Low-pass filter of resonance suppression (NLP, parameter P2-25)

The high value of inertia ratio will reduce the response bandwidth of speed loop. Therefore, the KVP value must be increased to maintain the response bandwidth. During the process of increasing the KVP value, it might cause machinery resonance. Please use this parameter to eliminate the noise of resonance. The higher the value is, the better the capability of reducing high-frequency noise will be. However, if the value is set too high, it would cause the instability of speed loop and overshoot. It is suggested to set the value as the following:

$$NLP \leq \frac{10000}{6 \times \text{Response bandwidth of speed loop (Hz)}}$$

- Anti-interference gain (DST, parameter P2-26)

This parameter is used to strengthen the ability of resisting external force and gradually eliminate overshoot during acceleration and deceleration. Its default value is 0. It is suggested not to adjust the value in manual mode, unless it is for fine-tuning.

- Position feed forward gain (PFG, parameter P2-02)

It can reduce the position error and shorten the settling time. However, if the value is set too high, it might cause overshoot. If the setting of e-gear ratio is bigger than 10, it might cause the noise as well.

(This page is intentionally left blank.)

Chapter 6 Control Mode of Operation

6.1 Selection of Operation Mode

Three basic operation modes are provided in this servo drive, position, speed, and torque. Users can use single mode (only in one-mode control) or dual mode to control. The following table lists all operation modes and description.

Mode Name	Short Name	Setting Code	Description	
Single Mode	Position mode (Terminal input)	PT	00	The servo drive receives position command and commands the motor to the target position. The position command is input via terminal block and receives pulse signal.
	Position mode (Register input)	PR	01	The servo drive receives position command and commands the motor to the target position. The position command is issued by register (64 sets of register in total) and uses DI signal to select the register.
	Speed Mode	S	02	The servo drive receives speed command and commands the motor to the target speed. The speed command can be issued by register (3 sets of registers in total) or the analog voltage (-10V ~ +10V) transmitted through the external terminal block. DI signal is used to select the command source.
	Speed mode (No analog input)	Sz	04	The servo drive receives speed command and commands the motor to the target speed. The speed command is issued by register (3 sets of registers in total) and cannot be issued by the external terminal block. DI signal is used to select the command source.
	Torque mode	T	03	The servo drive receives torque command and commands the motor to the target torque. The torque command can be issued by register (3 sets of registers in total) or the analog voltage (-10V ~ +10V) transmitted through the external terminal block. DI signal is used to select the command source.

Mode Name		Short Name	Setting Code	Description
	Torque mode (No analog input)	Tz	05	The servo drive receives torque command and commands the motor to the target torque. The torque command can be issued by register (3 sets of registers in total) and cannot be issued by the external terminal block. DI signal is used to select the command source.
Dual Mode		PT-S	06	Switch the mode of PT and S via DI signal.
		PT-T	07	Switch the mode of PT and T via DI signal.
		PR-S	08	Switch the mode of PR and S via DI signal.
		PR-T	09	Switch the mode of PR and T via DI signal.
		S-T	0A	Switch the mode of S and T via DI signal.
		PT-PR	0D	Switch the mode of PT and PR via DI signal.
Multi-mode		PT-PR-S	0E	Switch the mode of PT, PR, and S via DI signal.
		PT-PR-T	0F	Switch the mode of PT, PR, and T via DI signal.
Communication Mode	CANopen	0B	CANopen mode (use with Delta PLC)	
			DMCNET mode	
	CANopen	0C	CANopen mode	
			EtherCAT mode	

The steps of changing modes:

- (1) Switch the servo drive to Servo Off status. Turning SON signal of digit input to be off can complete this action.
- (2) Use parameter P1-01. (Refer to chapter 8).
- (3) After the setting is completed, cut the power off and restart the drive again.

The following sections describe the operation of each control mode, including control structure, command source, and loop gain adjustment, etc.

6.2 Position Mode

Position control mode is applicable in precise positioning, such as industrial machinery. The ASDA-A2 servo drive has two command input modes: pulse and internal register. The servo drive receives the pulse command for motor running direction and pulse input of up to 4 Mpps. For better position control, the ASDA-A2 provides 64 sets of position command registers with two input applications. The first one is that you can set different position values for the 64 command registers before operation, and then use DI.POS0 – POS5 of the CN1 for switching. For the second application, you can change the command register value through communication. To avoid the discontinuousness when the command register switches, the servo drive provides Position Spine Line (P-curve) for you to plan the motion. In the position closed-loop system, it mainly applies Speed mode and uses the external incremental type position controller and pre-compensation as auxiliary. Same as the Speed mode, two types of control mode (manual and auto) are available for selection. This chapter only provides descriptions for incremental type position controllers, pre-compensation and position command processing. There are two types of Position mode, PT and PR. The PT command is the pulse input through the connector while the PR command is determined by P6-00 – P7-27.

6.2.1 Position Command in PT Mode

PT position command is the pulse input from terminal block. There are three types of pulse and each type has positive / negative logic which can be set in parameter P1-00. See as the followings.

P1-00▲	PTT	External Pulse Input Type		Address: 0100H 0101H
Operational Interface :	Panel / Software	Communication		Related Section: 6.2.1
Default :	0x0002			
Control Mode :	PT			
Unit :	-			
Range :	0x0000 ~ 0x1142			
Data Size :	16-bit			
Format :	Hexadecimal			

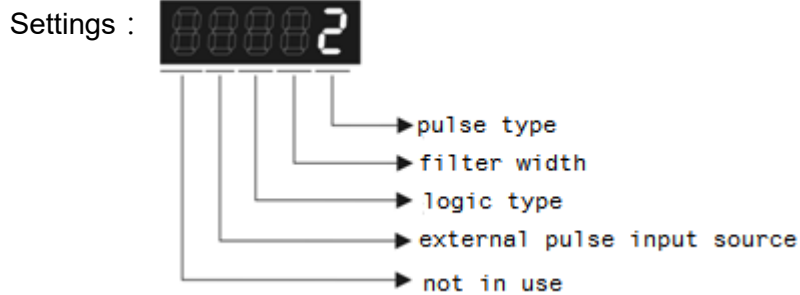

- Pulse Type
 - 0: AB phase pulse (4x)
 - 1: Clockwise (CW) and Counterclockwise (CCW) pulse
 - 2: Pulse + symbol
 - Other settings: reserved

- Filter Width

If the received frequency is much higher than the setting, it will be regarded as the noise and filtered out.

Setting Value	Min. pulse width*note1 (Low-speed filter frequency)	Setting Value	Min. pulse width*note1 (High-speed filter frequency)
0	600 ns (0.83 Mpps)	0	150 ns (3.33 Mpps)
1	2.4 us (208 Kpps)	1	600 ns (0.83 Mpps)
2	4.8 us (104 Kpps)	2	1.2 us (416 Kpps)
3	9.6 us (52 Kpps)	3	2.4 us (208 Kpps)
4	No filter function	4	No filter function

Note: 1) When the source of external pulse is from the high-speed differential signal and the setting value is 0 (the high-speed filter frequency is 3.33 Mpps at the moment), then:

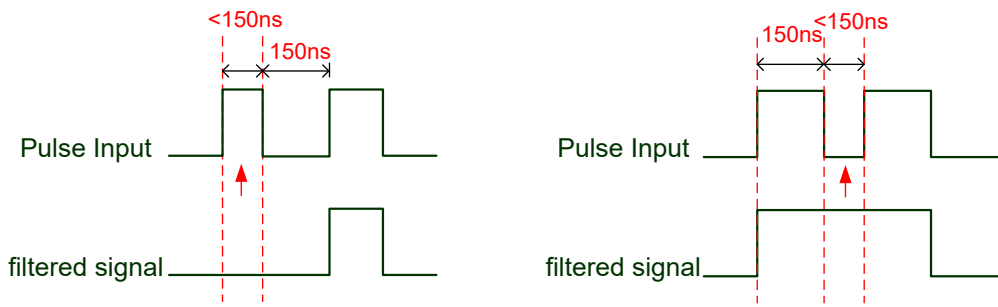

When this pulse width is shorter than 150 ns, it will be regarded as low level. Two input pulses will be regarded as one.

When this pulse width is shorter than 150 ns, it will be regarded as high level. Two input pulses will be regarded as one.

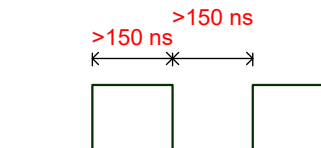

When High, Low duty of the pulse width are longer than 150 ns, it can ensure the pulse command will not be filtered.

If the user uses 2 ~ 4 MHz input pulse, it is suggested to set the filter value to 4.

Note: When the signal is the high-speed pulse specification of 4 Mpps and the settings value of the filter is 4, then the pulse will not be filtered.

● Logic Type

Logic	Pulse Type	High-speed and Low-speed Pulse Input	
		Forward	Reverse
0	Positive Logic	<p>AB phase pulse</p> <p>A Pulse Phase Lead</p>	<p>A Pulse Phase Lag</p>
		<p>CW and CCW pulse</p>	
	<p>Pulse + Symbol</p> <p>HSign = high</p>	<p>HSign = low</p>	

Logic	Pulse Type	High-speed Pulse Input	
		Forward	Reverse
0	Positive Logic	<p>HSign = high</p>	<p>HSign = low</p>

Logic	Pulse Type	Low-speed Pulse Input	
		Forward	Reverse
0	Positive Logic	<p>Sign = low</p>	<p>Sign = high</p>

For digital circuit, it uses 0 and 1 to represent two status, high voltage and low voltage. In Positive Logic, 1 represents high voltage and 0 represents low voltage and vice versa in Negative Logic.

For example:

Positive Logic

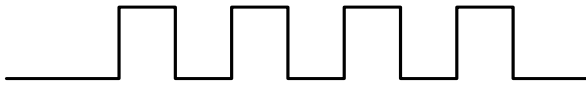

Negative Logic

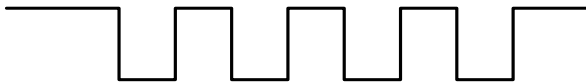

Pulse Specification		Max. Input Frequency	Minimum time width					
			T1	T2	T3	T4	T5	T6
High-speed pulse	Differential Signal	4 Mpps	62.5ns	125ns	250ns	200ns	125ns	125ns
Low-speed pulse	Differential Signal	500 Kpps	0.5 μ s	1 μ s	2 μ s	2 μ s	1 μ s	1 μ s
	Open-collector	200 Kpps	1.25 μ s	2.5 μ s	5 μ s	5 μ s	2.5 μ s	2.5 μ s

Pulse Specification		Max. Input Frequency	Voltage Specification	Forward Current
High-speed pulse	Differential Signal	4 Mpps	5V	< 25 mA
Low-speed pulse	Differential Signal	500 Kpps	2.8V ~ 3.7V	< 25 mA
	Open-collector	200 Kpps	24V (Max.)	< 25 mA

- The Source of External Pulse:
 - 0: Low-speed optical coupler (CN1 Pin: PULSE, SIGN)
 - 1: High-speed differential (CN1 Pin: HPULSE, HSIGN)

Position pulse can be input from CN1 terminal, PULSE (43), /PULSE (41), HPULSE (38), /HPULSE (29) and SIGN (36), /SIGN (37), HSIGN (46), /HSIGN (40). It could be open-collector or Line Driver. Please refer to section 3.4.3 for wiring method.

6.2.2 Position Command in PR Mode

PR position command source of each axis is from the 64 sets of register which are constituted by parameters (P6-00, P6-01) ~ (P7-26, P7-27). When going with the external DI/DO (CN1, POS0 ~ POS5 and CTRG), one of the previous 64 sets of register can be selected as the position command. See the following table:

Position Command	POS5	POS4	POS3	POS2	POS1	POS0	CTRG	Parameters
P0	0	0	0	0	0	0	↑	P6-00
								P6-01
P1	0	0	0	0	0	1	↑	P6-02
								P6-03
~								~
P50	1	1	0	0	1	0	↑	P6-98
								P6-99
P51	1	1	0	0	1	1	↑	P7-00
								P7-01
~								~
P63	1	1	1	1	1	1	↑	P7-26
								P7-27

Status of POS0 ~ POS5: 0 means the DI is OFF; 1 means the DI is ON.

CTRG↑: the moment DI is from OFF to ON.

The application of absolute type and incremental type registers is rather extensive. It is more like a simple procedure control. Users can complete the cyclic operation by referring to the above table. For example, position command P1 is 10 turns and P2 is 20 turns. P1 is issued first and P2 comes after. The following diagram shows the difference of both.

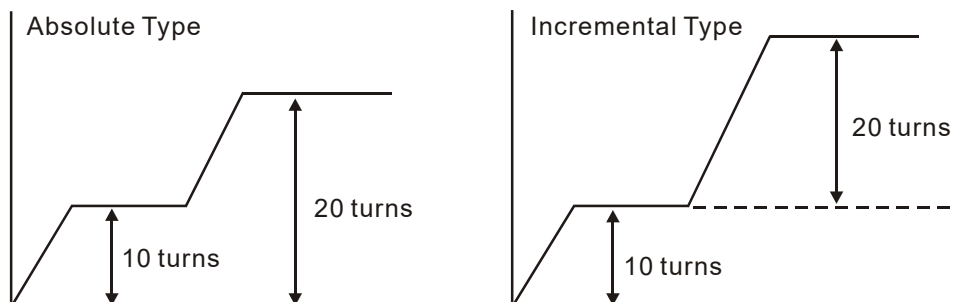

6.2.3 Control Structure of Position Mode

The basic control structure is as the following diagram:

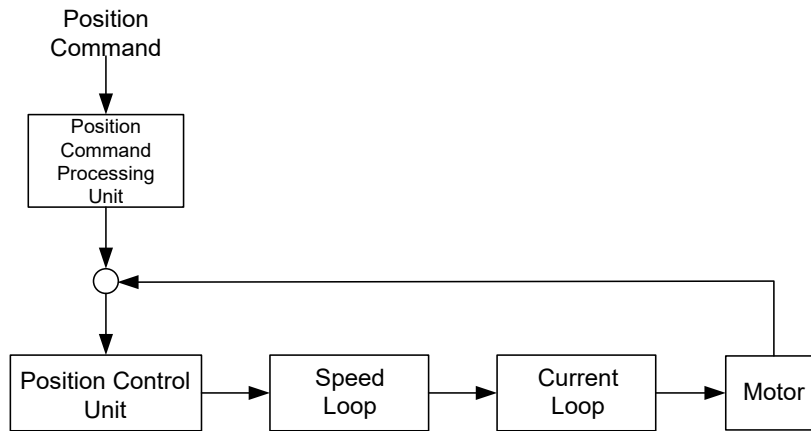

For a better control, the pulse signal should be processed and modified through position command processing unit. The structure is shown as the diagram below.

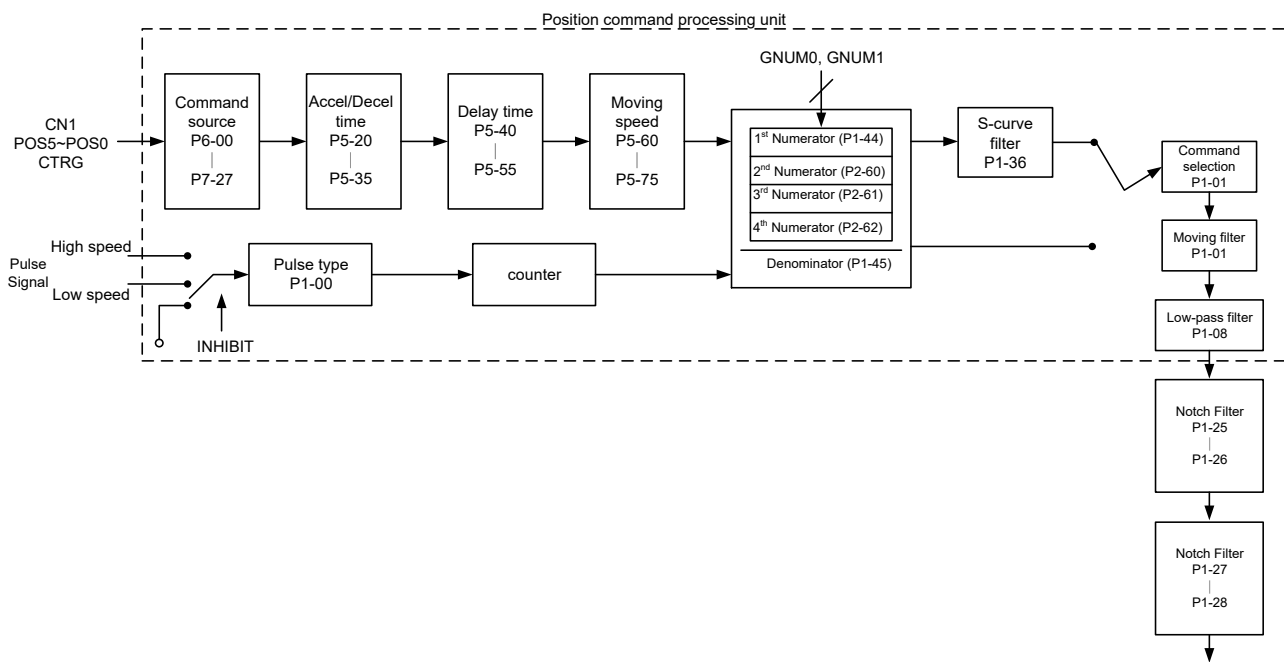

The upper path of the above diagram is PR mode and the lower one is PT mode, which could be selected via P1-01. Both modes can set E-gear ratio for the proper position resolution. Moreover, either S-curve filter or low-pass filter can be used to smooth the command. See the description in later parts.

Pulse Command Inhibit Input Function (INHP)

Use DI to select INHP (Refer to P2-10 to P2-17 and Table 8.1 INHP (45)) before using this function. If not, this function will be unable to use. When DI (INHP) is ON, the pulse command will be cleared in position control mode and the motor will stop running. (Only DI8 supports this function.)

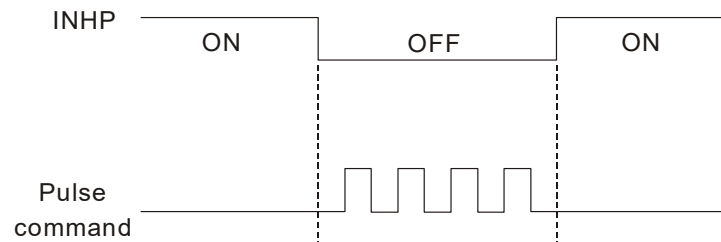

6.2.4 S-curve Filter (Position)

S-curve filter smooths the motion command. With S-curve filter, the process of acceleration becomes more continuous and the jerk will be smaller. It not only improves the performance when the motor accelerates or decelerates, but also smooths the operation of mechanical structure. When the load inertia increases, the operation of the motor will be influenced by friction and inertia during the time of activation and stop. However, the situation can be improved by increasing the value of Acceleration / Deceleration Constant of S-Curve (TSL), Acceleration Constant of S-Curve (TACC), and Deceleration Constant of S-Curve (TDEC). When the position command source is pulse, its speed and angular acceleration is continuous. Thus, S-curve filter is not a must.

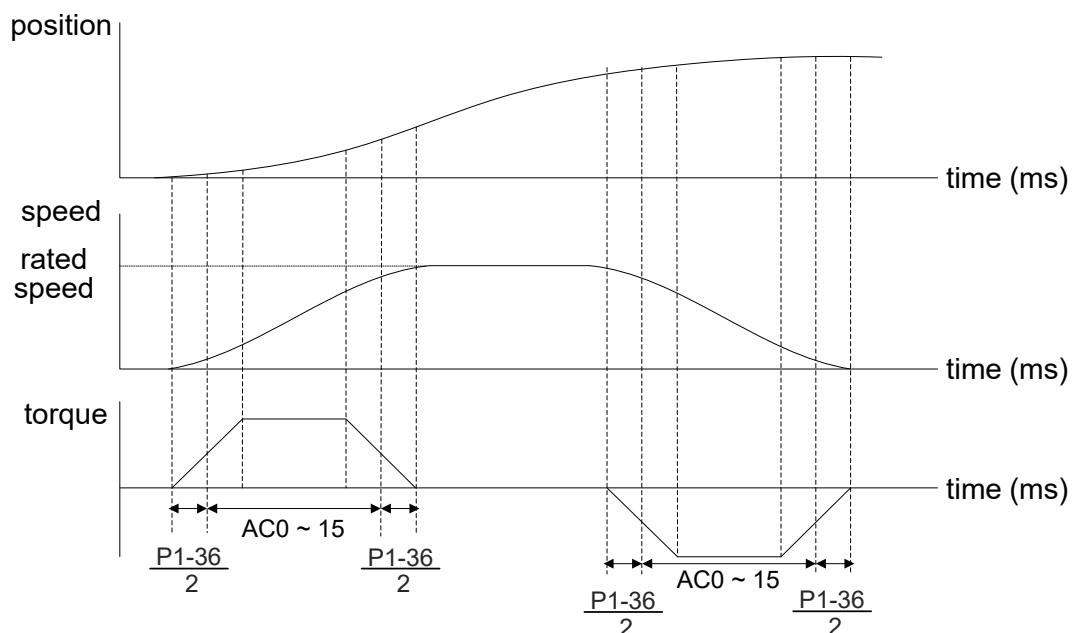

Position and speed S-curve and time setting (acceleration for position command)

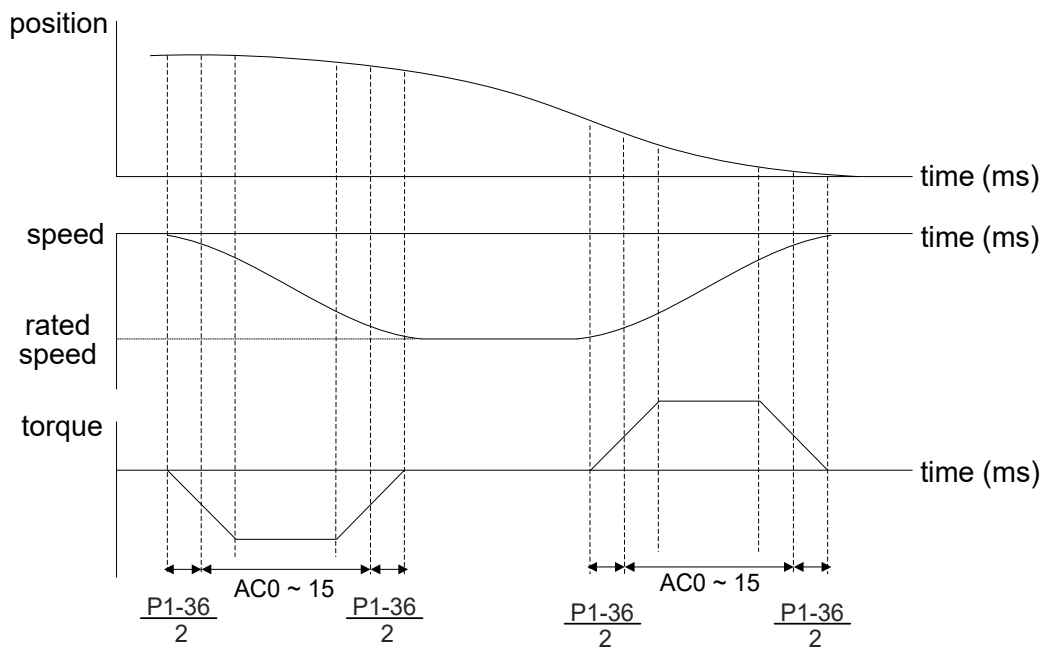

Position and speed S-curve and time setting (deceleration for position command)

Related Parameters:

P1-34	TACC	Acceleration Constant of S-Curve		Address: 0144H 0145H
	Operational Interface :	Panel / Software	Communication	Related Section: 6.3.3
	Default :	200		
	Control Mode :	S		
	Unit :	ms		
	Range :	1 ~ 65500		
	Data Size :	16-bit		
	Format :	Decimal		

Settings : Acceleration Constant of Speed:
 P1-34, P1-35, P1-36, and the acceleration time of speed command from zero to the rated speed all can be set individually. Even when P1-36 is set to 0, it still has acceleration / deceleration of trapezoid-curve.

- Note: 1) When the source of speed command is analog and P1-36 is set to 0, it will disable S-curve function.
 2) When the source of speed command is analog, the max. range of P1-34 will be set within 20000 automatically.

P1-35	TDEC	Deceleration Constant of S-Curve		Address: 0146H 0147H
	Operational Interface :	Panel / Software	Communication	
Default :	200			
Control Mode :	S			
Unit :	ms			
Range :	1 ~ 65500			
Data Size :	16-bit			
Format :	Decimal			

Settings : Deceleration Constant of Speed:
P1-34, P1-35, P1-36, and the deceleration time of speed command from the rated speed to zero all can be set individually. Even when P1-36 is set to 0, it still has acceleration / deceleration of trapezoid-curve.

Note: 1) When the source of speed command is analog, and P1-36 is set to 0, it will disable S-curve function.

2) When the source of speed command is analog, the max. range of P1-35 will be set within 20000 automatically.

P1-36	TSL	Acceleration / Deceleration Constant of S-Curve		Address: 0148H 0149H
	Operational Interface :	Panel / Software	Communication	
Default :	0			
Control Mode :	S / PR			
Unit :	ms			
Range :	0 ~ 65500 (0: disable this function)			
Data Size :	16-bit			
Format :	Decimal			

Settings : Acceleration / Deceleration Constant of S-Curve:
Speed

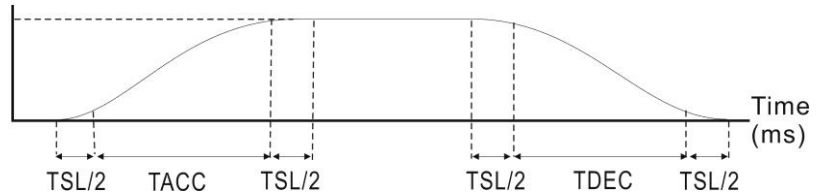

P1-34: Set the acceleration time of acceleration / deceleration of trapezoid-curve

P1-35: Set the deceleration time of acceleration / deceleration of trapezoid-curve

P1-36: Set the smoothing time of S-curve acceleration and deceleration

P1-34, P1-35, and P1-36 can be set individually. Even when P1-36 is set to 0, it still has acceleration / deceleration of trapezoid-curve.

Version after V1.036 sub00 provides the compensation function of following error.

	P1-36 = 0	P1-36 = 1	P1-36 > 1
Smoothing function of S-curve	Disable	Disable	Enable
Compensation function of following error	Disable	Enable	Determined by P2-68.X

Note: 1) When the source of speed command is analog, and P1-36 is set to 0, it will disable S-curve function.

2) When the source of speed command is analog, the max. range of P1-36 will be set within 10000 automatically.

6.2.5 Electronic Gear Ratio

Related parameters:

P1-44 ▲	GR1	Gear Ratio (Numerator) (N1)		Address: 0158H 0159H
	Operational Interface :	Panel / Software	Communication	Related Section: 6.2.5
	Default :	128		
	Control Mode :	PT / PR		
	Unit :	Pulse		
	Range :	1 ~ (2 ²⁹ -1)		
	Data Size :	32-bit		

Format :	Decimal
----------	---------

Settings : Please refer to P2-60 to P2-62 for the setting of multiple gear ratio (numerator).

- Note:
- 1) In PT mode, the setting value can be changed when Servo ON.
 - 2) In PR mode, the setting value can be changed when Servo OFF.
 - 3) In communication mode (DMCNET / CANopen / EtherCAT), if you cycle power to the drive, the E-Gear ratio is set to the default value of the communication protocol. Resetting to the default value results in the reconstruction of the absolute coordinate system, so you must re-do the homing procedure. If you do not want the absolute coordinates to be reset to the default value, please set P3-12.Z to 1. For details, please refer to P3-12.

P1-45	GR2	Gear Ratio (Denominator) (M)		Address: 015AH 015BH
	Operational Interface :	Panel / Software	Communication	Related Section: 6.2.5
	Default :	10		
	Control Mode :	PT / PR		
	Unit :	Pulse		
	Range :	1 ~ (2 ³¹ -1)		
	Data Size :	32-bit		
	Format :	Decimal		

Settings : If the setting is wrong, the servo motor will easily have sudden unintended acceleration.

Please follow the rules for setting:

The setting of pulse input:

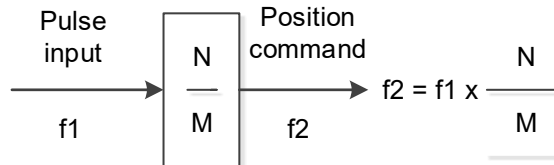

Range of command pulse input: 1 / 50 < Nx / M < 25600

- Note:
- 1) The setting value cannot be changed when Servo ON is neither in PT nor in PR mode.
 - 2) In communication mode (DMCNET / CANopen / EtherCAT), if you cycle the power to the drive, the E-Gear ratio is set to the default value of the communication protocol. Resetting to the default value results in the reconstruction of the absolute coordinate system, so you must re-do the homing procedure. If you do not want the absolute coordinates to be reset to the default value, please set P3-12.Z to 1. For details, please refer to P3-12.

$$\text{E-Gear ratio} = \left(\frac{N}{M}\right) = \frac{P1-44}{P1-45}, \text{ has to match } \frac{1}{50} \leq \left(\frac{N}{M}\right) \leq 5000$$

Electronic gear provides simple ratio change of travel distance. The high electronic gear ratio would cause the position command to be the stepped command. S-curve or low-pass filter can be used to improve the situation. When electronic gear ratio is set to 1, the motor will turn one cycle for every 10000 pulse/rev. When electronic gear ratio is changed to 0.5, then every two pulses from the command will be referred to one pulse of motor encoder.

For example (rotary motor): after setting the electronic gear ratio properly, the moving distance of the object is 1 μm /pulse, which is easier to use.

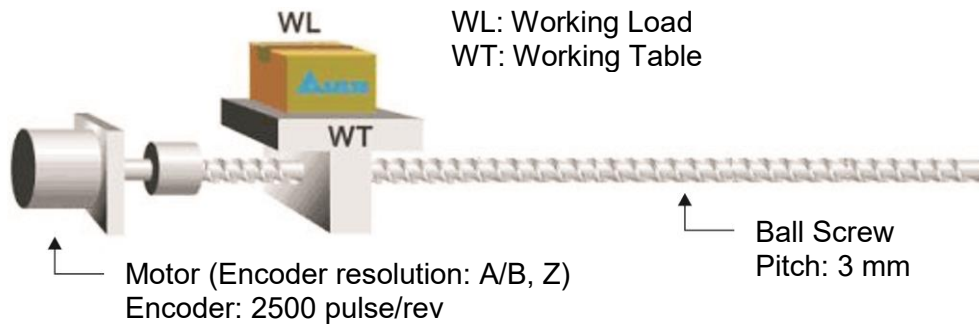

	Gear Ratio	Moving distance of each pulse command
Electronic gear is unapplied.	$= \frac{1}{1}$	$= \frac{3 \times 1000}{4 \times 2500} = \frac{3000}{10000} = \mu\text{m}$
Electronic gear is applied.	$= \frac{10000}{3000}$	$= 1 \mu\text{m}$

6.2.6 Low-pass Filter

Related parameter:

P1-08	PFLT	Smooth Constant of Position Command (Low-pass Filter)	Address: 0110H 0111H
	Operational Interface :	Panel / Software Communication	Related Section: 6.2.6
	Default :	0	
	Control Mode :	PT / PR	
	Unit :	10 ms	
	Range :	0 ~ 1000	
	Data Size :	16-bit	
	Format :	Decimal	
	Example :	11 = 110 ms	

Settings : 0: Disabled

6.2.7 Timing Diagram in Position Mode (PR)

In PR mode, the position command is selected by DI signal (POS0 ~ POS5 and CTRG) of CN1. Please refer to Section 6.2.2 for the information about DI signal and its selected register. Followings are the timing diagrams.

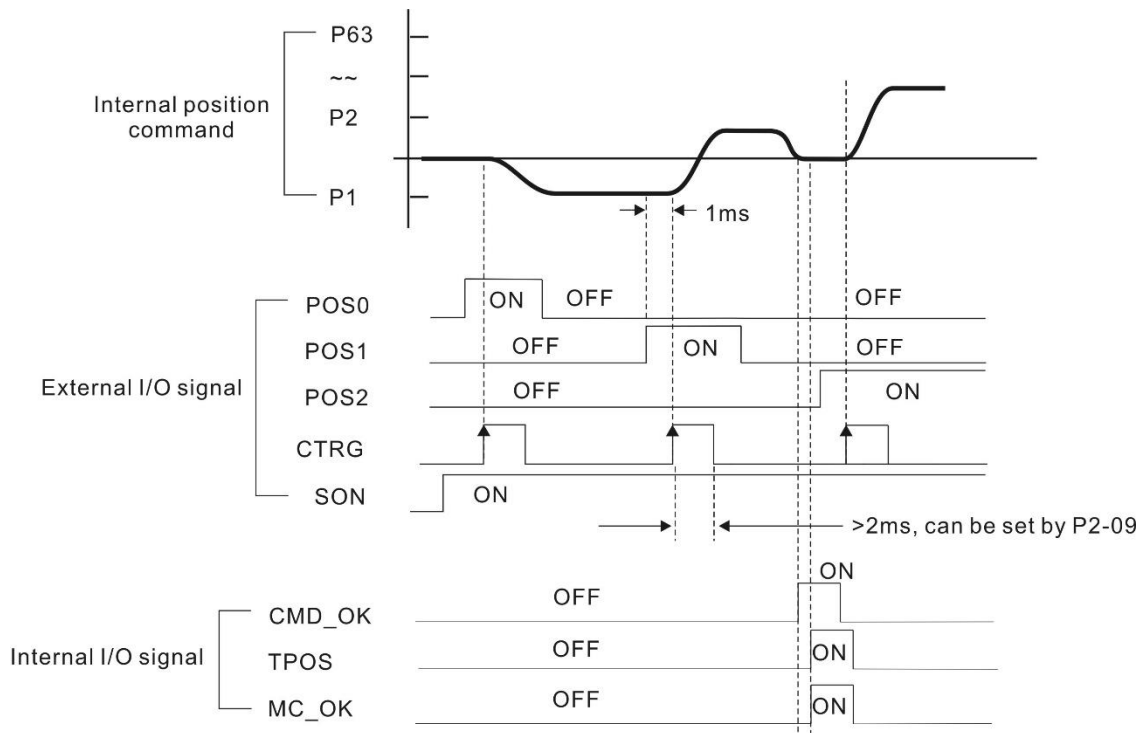

CMD_OK : CMD_OK is activated when the servo drive has detected that Pr command has been completed

TPOS: TPOS is on when the motor speed is lower than the speed set in P1-38.

MC_OK : MC_OK is activated when CMD_OK and TPOS are both ON.

6.2.8 Gain Adjustment of Position Loop

Before setting the position control unit, users have to manually (P2-32) complete the setting of speed control unit since the speed loop is included in position loop. Then, set the proportional gain (parameter P2-00) and feed forward gain (parameter P2-02) of position loop. Users also can use the auto mode to set the gain of speed and position control unit automatically.

- 1) Proportional gain: Increase the gain so as to enhance the response bandwidth of position loop.
- 2) Feed forward gain: Minimize the deviation of phase delay.

The position loop bandwidth cannot exceed the speed loop bandwidth. It is suggested that $f_p \leq \frac{f_v}{4}$.

f_v : response bandwidth of speed loop (Hz).

$KPP = 2 \times \pi \times f_p$.

f_p : response bandwidth of position loop (Hz).

For example, the desired position bandwidth is 20 Hz $\rightarrow KPP = 2 \times \pi \times 20 = 125$.

Related parameters:

P2-00	KPP	Position Loop Gain		Address: 0200H 0201H
Operational Interface :	Panel / Software	Communication		Related Section: 6.2.8
Default :	35			
Control Mode :	PT / PR			
Unit :	rad/s			
Range :	0 ~ 2047			
Data Size :	16-bit			
Format :	Decimal			

Settings : When the value of position loop gain is increased, the position response can be enhanced and the position error can be reduced. If the value is set too big, it may easily cause vibration and noise.

P2-02	PFG	Position Feed Forward Gain		Address: 0204H 0205H
	Operational Interface :	Panel / Software	Communication	Related Section: 6.2.8
	Default :	50		
	Control Mode :	PT / PR		
	Unit :	%		
	Range :	0 ~ 100		
	Data Size :	16-bit		
	Format :	Decimal		

Settings : If the position command is changed smoothly, increasing the gain value can reduce the position following error.
 If the position command is not changed smoothly, decreasing the gain value can tackle the problem of mechanical vibration.

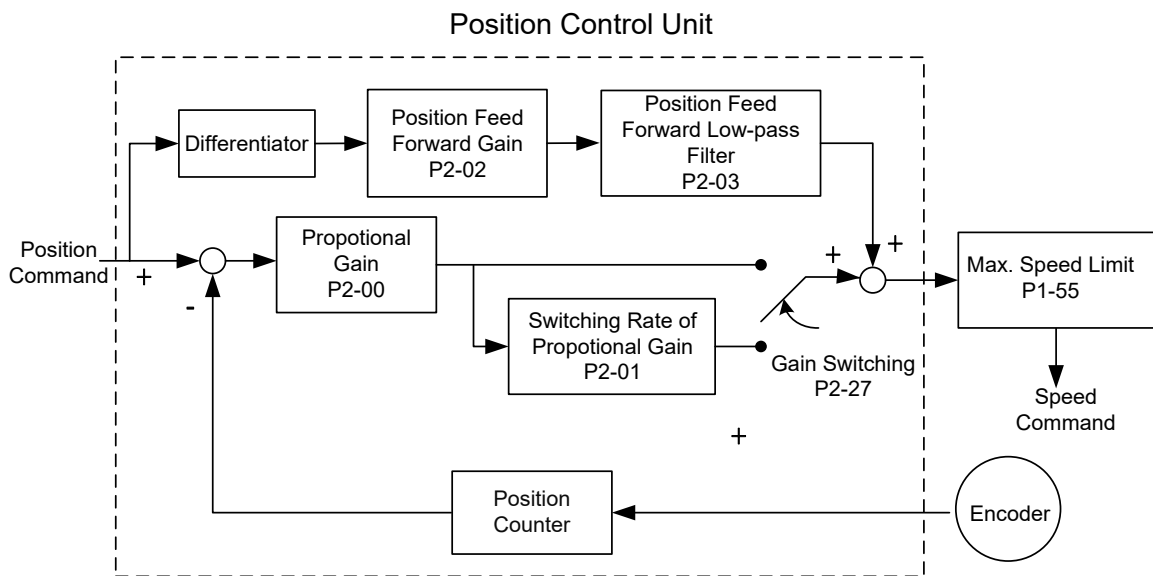

When the value of proportional gain, KPP, is set too big, the bandwidth of position loop will be increased and diminish the phase margin. And the motor rotor rotates vibrantly in forward and reverse directions at the moment. Thus, KPP has to be decreased until the rotor stops vibrating. When the external torque interrupts, the over-low KPP cannot meet the demand of position error. In this situation, parameter P2-02 can effectively reduce the following error.

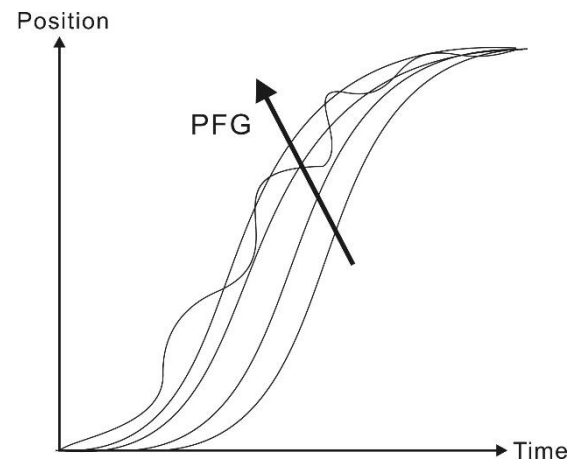
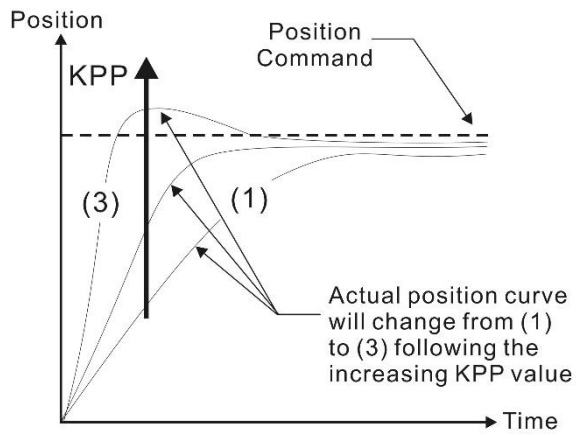

6.2.9 Low-frequency Vibration Suppression in Position Mode

If the stiffness is not enough, the mechanical transmission will continue to vibrate even when the motor stops after completing the positioning command. The function of low-frequency vibration suppression can eliminate the vibration of mechanical transmission. The range is between 1.0 Hz and 100.0 Hz. Both manual setting and auto setting are provided.

Auto setting:

If it is difficult to find the frequency, enable the function of auto low-frequency vibration suppression to automatically search the frequency of low-frequency vibration. If P1-29 is set to 1, the system will disable the function of low-frequency vibration suppression automatically and start to search the vibration frequency. When the detected frequency remains at the same level, P1-29 will be set to 0 automatically and set the first frequency in P1-25 and set P1-26 to 1. The second frequency will be set in P1-27 and then set P1-28 to 1. If P1-29 is automatically set back to 0 and the low-frequency vibration still exists, please check if the function of P1-26 or P1-28 is enabled. If the values of P1-26 and P1-28 are both 0, it means no frequency has been detected. Please decrease the value of P1-30 and set P1-29 to 1 so as to search the vibration frequency again. Please note that when the detection level is set too small, the noise will be regarded as the low-frequency vibration.

Flowchart of auto low-frequency vibration suppression:

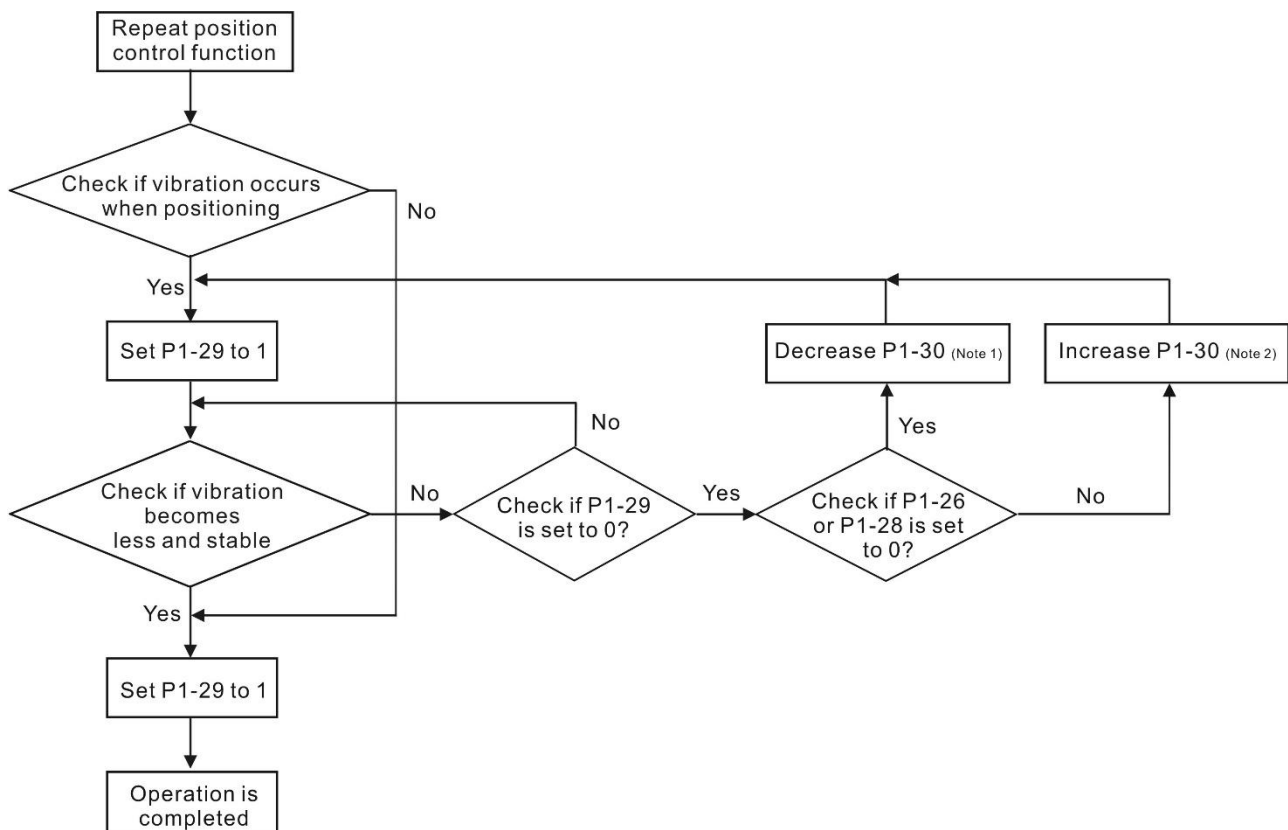

Note 1: When the values of P1-26 and P1-28 are both 0, it means it is unable to search the frequency.

It is probably because the detection level is set too high and is unable to detect the low-frequency vibration.

Note 2: When the value of P1-26 or P1-28 is not set to 0 and the vibration still cannot be reduced, it is probably because the detection level is set too low, and the system regards the noise or other non-primary frequency as the low-frequency vibration.

Note 3: When the process of auto vibration suppression is completed and the vibration still cannot be diminished, P1-25 or P1-27 can be manually set to suppress the vibration if the frequency (Hz) of the low-frequency vibration is identified.

Related parameters:

P1-29	AVSM	Auto Low-frequency Vibration Suppression Setting		Address: 013AH 013BH
	Operational Interface :	Panel / Software	Communication	Related Section: 6.2.9
	Default :	0		
	Control Mode :	PT / PR		
	Unit :	-		
	Range :	0 ~ 1		
	Data Size :	16-bit		
	Format :	Decimal		

Settings : 0: Disable the automatic low-frequency vibration detection function.

1: Disable the function automatically after vibration suppression. The value resets to 0 automatically.

Description of Auto Mode Setting:

When the value is 1, vibration suppression is in automatic mode. When the vibration cannot be detected or the vibration frequency is stable, the system resets the parameter to 0 and automatically saves the vibration suppression frequency to P1-25.

P1-30	VCL	Low-frequency Vibration Detection	Address: 013CH 013DH
Operational Interface :	Panel / Software	Communication	Related Section: 6.2.9
Default :	500		
Control Mode :	PT / PR		
Unit :	Pulse		
Range :	1 ~ 8000		
Data Size :	16-bit		
Format :	Decimal		

Settings : When enabling the auto suppression (P1-29 = 1), it will automatically search the detection level. The lower the value is, the more sensitive the detection will be. However, it is easy to misjudge the noise or regard the other low-frequency vibration as the suppression frequency. If the value is bigger, it will make more precise judgment. However, if the vibration of the mechanism is smaller, it might not detect the frequency of low-frequency vibration.

P1-30 is to set the range to detect the magnitude of low-frequency vibration. When the frequency is not being detected, it is probably because the value of P1-30 is set too big which exceeds the range of vibration. It is suggested to decrease the value of P1-30. Please note that if the value is too small, the system might regard the noise as the vibration frequency. If the SCOPE is available, it can be used to observe the range of position error (pulse) between upper and lower magnitude of the curve and set up the appropriate value of P1-30.

Manual Setting:

There are two sets of low-frequency vibration suppression filters. One is parameters P1-25 ~ P1-26 and the other is parameters P1-27 ~ P1-28. These two sets of filters can be used to eliminate two different frequency vibrations. Parameters P1-25 and P1-27 are used to suppress the low-frequency vibration. The function is working only when the parameter setting value of low-frequency vibration is close to the real vibration frequency. Parameters P1-26 and P1-28 are used to set the response after filtering. The bigger the setting value of P1-26 and P1-28 is, the better response will be. However, if the value is set too big, the motor might not operate smoothly. The default values of parameters P1-26 and P1-28 are 0, which means the function is disabled. Followings are the related parameters:

P1-25	VSF1	Low-frequency Vibration Suppression (1)		Address: 0132H 0133H
	Operational Interface :	Panel / Software	Communication	
Default :	1000			
Control Mode :	PT / PR			
Unit :	0.1 Hz			
Range :	10 ~ 1000			
Data Size :	16-bit			
Format :	Decimal			
Example :	150 = 15 Hz			

Settings : The setting value of the first low-frequency vibration suppression.
If P1-26 is set to 0, then it will disable the first low-frequency vibration suppression filter.

P1-26	VSG1	Low-frequency Vibration Suppression Gain (1)		Address: 0134H 0135H
	Operational Interface :	Panel / Software	Communication	
Default :	0			
Control Mode :	PT / PR			
Unit :	-			
Range :	0 ~ 9 (0: Disable the first low-frequency vibration suppression filter)			
Data Size :	16-bit			
Format :	Decimal			

Settings : The first low-frequency vibration suppression gain. The bigger value it is, the better the position response will be. However, if the value is set too big, the motor will not be able to smoothly operate. It is suggested to set the value to 1.

P1-27	VSF2	Low-frequency Vibration Suppression (2)		Address: 0136H 0137H
	Operational Interface :	Panel / Software	Communication	
Default :	1000			
Control Mode :	PT / PR			
Unit :	0.1 Hz			
Range :	10 ~ 1000			
Data Size :	16-bit			
Format :	Decimal			
Example :	150 = 15 Hz			

Settings : The setting value of the second low-frequency vibration suppression. If P1-28 is set to 0, then it will disable the second low-frequency vibration suppression filter.

P1-28	VSG2	Low-frequency Vibration Suppression Gain (2)		Address: 0138H 0139H
	Operational Interface :	Panel / Software	Communication	
Default :	0			
Control Mode :	PT / PR			
Unit :	-			
Range :	0 ~ 9 (0: Disable the second low-frequency vibration suppression filter)			
Data Size :	16-bit			
Format :	Decimal			

Settings : The second low-frequency vibration suppression gain. The bigger value it is, the better the position response will be. However, if the value is set too big, the motor will not be able to smoothly operate. It is suggested to set the value to 1.

6.3 Speed Mode

Speed control mode (S or Sz) is applicable in precision speed control, such as CNC machine tools. This servo drive includes two types of command input, analog and register. Analog command input can use external voltage to control the motor speed. There are two methods in register input. One is used before operation. Users set different value of speed command in three registers, and then use the CN1 DI signals, SPD0 and SPD1, for switching. The other method is to change the value of register by communication. In order to deal with the problem of non-continuous speed command when switching register, a complete S-curve program is provided. In close-loop system, this servo drive adopts gain adjustment and integrated PI controller and two modes (manual and auto) for selection.

In manual mode, users can set all parameters and all auto or auxiliary functions will be disabled. While in auto mode, it provides the functions of load inertia estimation and parameter adjustment. Meanwhile, parameters set by users will be regarded as the default value.

6.3.1 Selection of Speed Mode

There are two types of speed command source, analog voltage and internal parameters.

The selection is determined by CN1 DI signal. See as the followings.

Speed Command	CN1 DI signal		Command Source		Content	Range	
	SPD1	SPD0					
S1	0	0	Mode	S	External analog signal	Voltage difference between V-REF and GND	-10V ~ +10V
				Sz	N/A	Speed command is 0	0
S2	0	1	Register parameters		P1-09	-60000 ~ 60000	
S3	1	0			P1-10		
S4	1	1			P1-11		

- Status of SPD0 - SPD1: 0 means DI is OFF, 1 means DI is ON.
- When both SPD0 and SPD1 are 0, if it is in Sz mode, the command will be 0. Thus, if there is no need to use analog voltage as the speed command, Sz mode can be applied to tackle the problem of zero-drift. If it is in S mode, the command will be the voltage difference between V-REF and GND. The range of input voltage is between -10V and +10V, and its corresponding speed is adjustable (P1-40).
- When one of SPD0 and SPD1 is not 0, the speed command is from the internal parameter. The command is activated after changing the status of SPD0 - SPD1. There is no need to

use CTRG for triggering.

- The setting range of internal parameters is between -60000 and 60000.
Setting value = setting range x unit (0.1 r/min).

For example: P1-09 = +30000, setting value = +30000 x 0.1 r/min = +3000 r/min

The speed command not only can be issued in speed mode (S or Sz), but also in torque mode (T or Tz) as the speed limit.

6.3.2 Control Structure of Speed Mode

The basic control structure is shown as the following diagram:

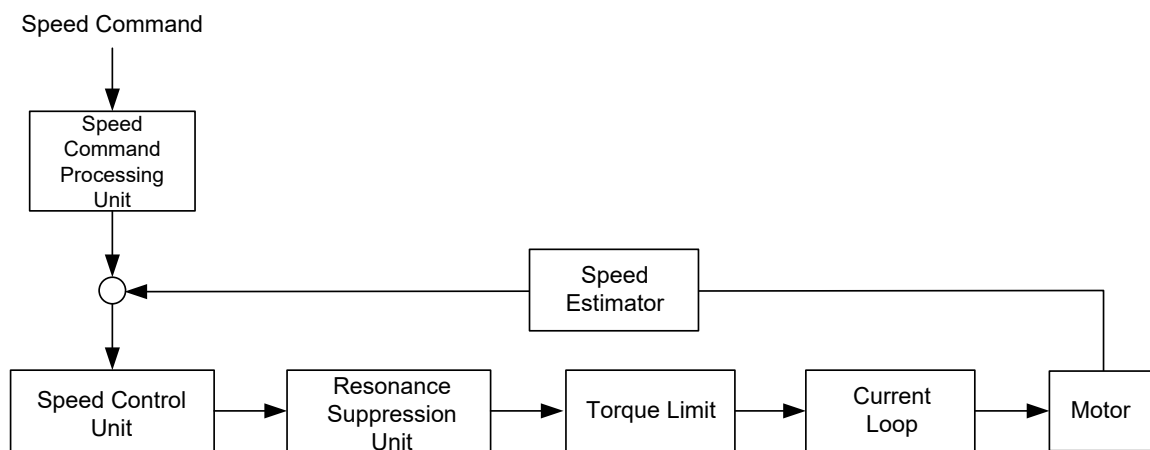

The speed command processing unit is to select speed command source according to Section 6.3.1, including the scaling (P1-40) setting and S-curve setting. The speed control unit manages the gain parameters of the servo drive and calculates the current command for servo motor in time. The resonance suppression unit is to suppress the resonance of mechanism. Detailed descriptions are shown as the following:

Here firstly introduces the function of speed command processing unit. Its structure is as the following diagram.

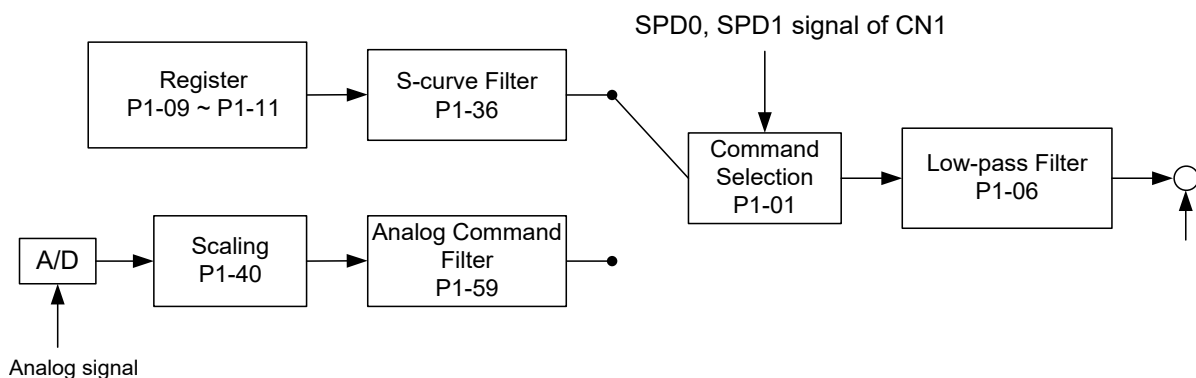

The upper path is the command from register while the lower one is external analog command. The command is selected according to the status of SPD0, SPD1, and P1-01(S or Sz). Usually, S-curve and low-pass filter are applied for having a smooth resonance of command.

6.3.3 Smooth Speed Command

S-curve Filter

During the process of acceleration or deceleration, S-curve filter applies the program of three-stage acceleration curve for smoothing the motion command, which generates the continuous acceleration. It is for avoiding the jerk (the differentiation of acceleration) came from the sudden command change and indirectly causes the resonance and noise. Users can use acceleration constant of S-curve (TACC) to adjust the slope changed by acceleration, deceleration constant of S-curve (TDEC) to adjust the slope changed by deceleration, and acceleration / deceleration constant of S-curve (TSL) to improve the status of motor activation and stop. The calculation of the time to complete the command is provided.

T (ms) signifies the operation time and S (r/min) signifies the absolute Speed command, which is the absolute value of the initial speed minus the end speed.

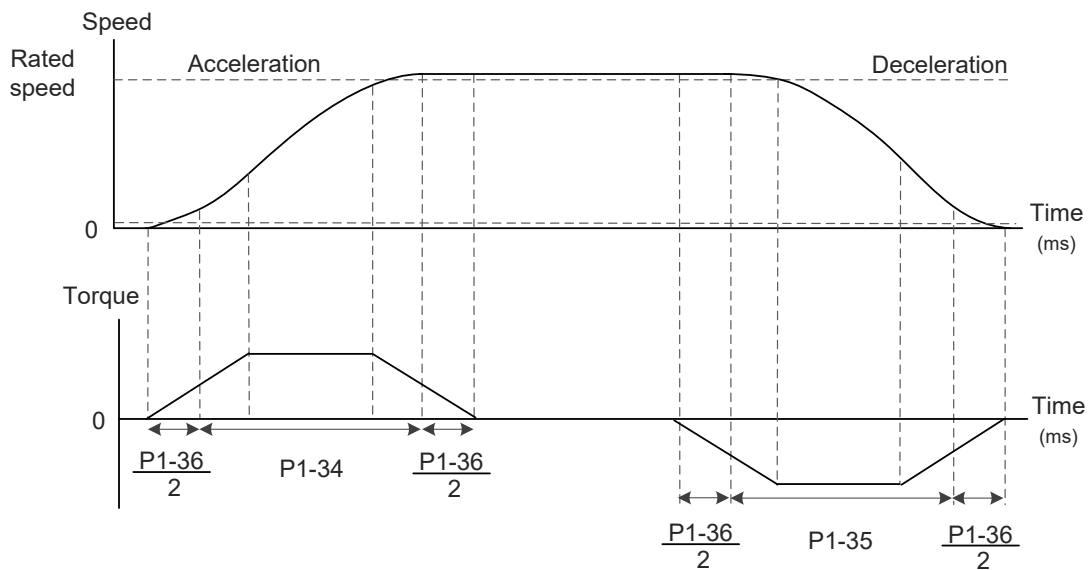

S-curve and Time setting

Related parameters:

P1-34	TACC	Acceleration Constant of S-Curve		Address: 0144H 0145H
Operational Interface :	Panel / Software	Communication	Related Section: 6.3.3	
Default :	200			
Control Mode :	S			
Unit :	ms			
Range :	1 ~ 65500			
Data Size :	16-bit			
Format :	Decimal			

Settings : Acceleration Constant of speed:
P1-34, P1-35, P1-36, and the acceleration time of speed command from zero to the rated speed all can be set individually. Even when P1-36 is set to 0, it still has acceleration / deceleration of trapezoid-curve.

- Note: 1) When the source of speed command is analog, and P1-36 is set to 0, it will disable S-curve function.
- 2) When the source of speed command is analog, the max. range of P1-34 will be set within 20000 automatically.

P1-35	TDEC	Deceleration Constant of S-Curve		Address: 0146H 0147H
Operational Interface :	Panel / Software	Communication	Related Section: 6.3.3	
Default :	200			
Control Mode :	S			
Unit :	ms			
Range :	1 ~ 65500			
Data Size :	16-bit			
Format :	Decimal			

Settings : Deceleration Constant of speed:
P1-34, P1-35, P1-36, and the deceleration time of speed command from the rated speed to zero all can be set individually. Even when P1-36 is set to 0, it still has acceleration / deceleration of trapezoid-curve.

- Note: 1) When the source of speed command is analog, and P1-36 is set to 0, it will disable S-curve function.
- 2) When the source of speed command is analog, the max. range of P1-35 will be set within 20000 automatically.

P1-36	TSL	Acceleration / Deceleration Constant of S-Curve	Address: 0148H 0149H
Operational Interface :	Panel / Software	Communication	Related Section: 6.3.3
Default :	0		
Control Mode :	S / PR		
Unit :	ms		
Range :	0 ~ 65500 (0: disable this function)		
Data Size :	16-bit		
Format :	Decimal		

Settings : Acceleration / Deceleration Constant of S-Curve:
Speed

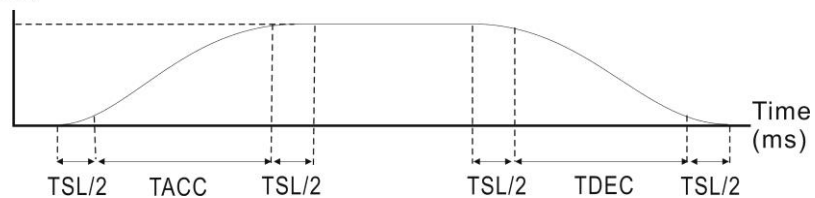

P1-34: Set the acceleration time of acceleration / deceleration of trapezoid-curve

P1-35: Set the deceleration time of acceleration / deceleration of trapezoid-curve

P1-36: Set the smoothing time of S-curve acceleration and deceleration

P1-34, P1-35, and P1-36 can be set individually. Even when P1-36 is set to 0, it still has acceleration / deceleration of trapezoid-curve.

Version after V1.036 sub00 provides the compensation function of following error.

	P1-36 = 0	P1-36 = 1	P1-36 > 1
Smoothing function of S-curve	Disable	Disable	Enable
Compensation function of following error	Disable	Enable	Determined by P2-68.X

- Note: 1) When the source of speed command is analog, and P1-36 is set to 0, it will disable S-curve function.
- 2) When the source of speed command is analog, the max. range of P1-36 will be set within 10000 automatically.

Analog Speed Command Filter

Analog speed command filter is provided especially for ASDA-A2 series users. It mainly helps with buffer when the analog input signal changes too fast.

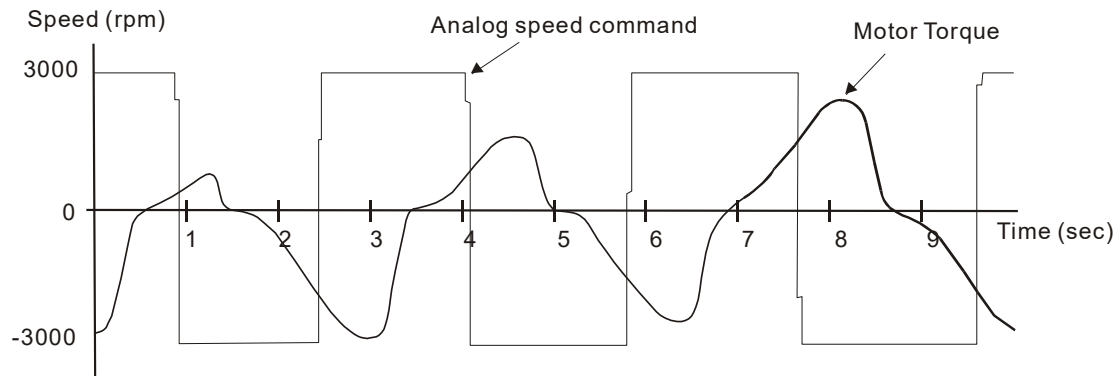

Analog speed command filter smoothes the analog input command. Its time program is the same as S-curve filter in normal speed. Also, the speed curve and the acceleration curve are both continuous. The above is the diagram of analog speed command filter. The slope of speed command in acceleration and deceleration is different. Users could adjust the time setting (P1-34, P1-35, and P1-36) according to the actual situation to improve the performance.

Command End Low-pass Filter

It is usually used to eliminate the unwanted high-frequency response or noise. It also can smooth the command.

Related parameter:

P1-06	SFLT	Analog Speed Command (Low-pass Filter)		Address: 010CH 010DH
Operational Interface :	Panel / Software	Communication		Related Section: 6.3.3
Default :	0			
Control Mode :	S / Sz			
Unit :	ms			
Range :	0 ~ 1000 (0: disable this function)			
Data Size :	16-bit			

Format :	Decimal
----------	---------

Settings : 0: Disabled

6.3.4 The Scaling of Analog Command

The motor speed command is controlled by the analog voltage difference between V_REF and VGND. Use parameter P1-40 to adjust the speed-control slope and its range.

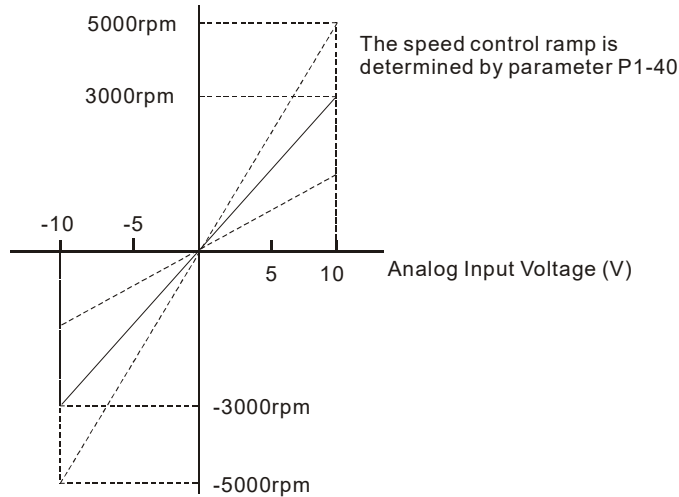

Related parameter:

For example, if you set P1-40 to 2000, when the input voltage is 10V, the speed command is 2000 r/min.

P1-40	VCM	Maximum Speed of Analog Speed Command		Address: 0150H 0151H
	Operational Interface :	Panel / Software	Communication	Related Section: 6.3.4
	Default :	Same as the rated speed of each model		
	Control Mode :	S / T		
	Unit :	r/min		
	Range :	0 ~ 5000		
	Data Size :	32-bit		
	Format :	Decimal		

Settings : Maximum Speed of Analog Speed Command:

In speed mode, the analog speed command inputs the swing speed setting of the max. voltage (10V).

For example, if the setting is 3000, when the external voltage input is 10V, it means the speed control command is 3000 r/min. If the external voltage input is 5V, then the speed control command is 1500 r/min.

Speed control command = input voltage value x setting value/10

In torque mode, analog speed limit inputs the swing speed limit setting of the max. voltage (10V).

Speed limit command = input voltage value x setting value/10

6.3.5 Timing Diagram in Speed Mode

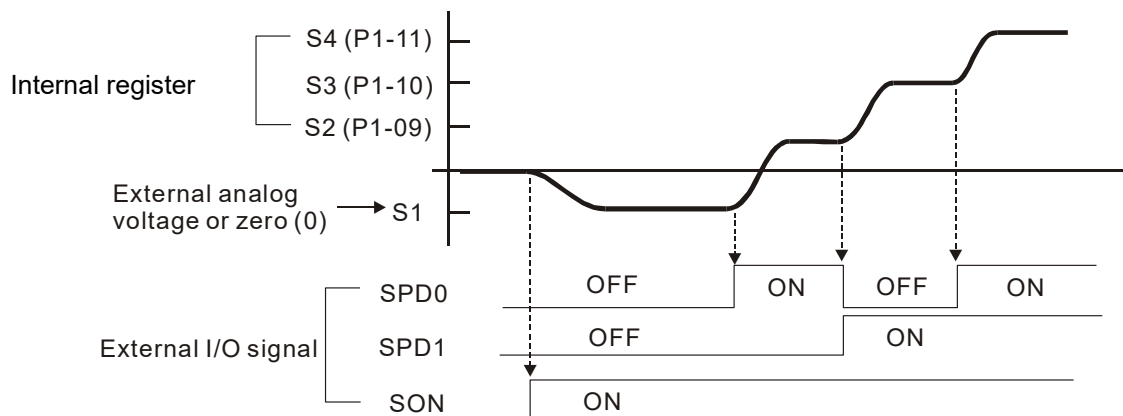

Note:

- 1) OFF means the contact point is open while ON means the contact point is close.
- 2) When it is in Sz mode, the speed command S1 = 0; when it is in S mode, the speed command S1 is the external analog voltage input.
- 3) When the servo drive is On, please select the command according to SPD0 - SPD1 status.

6.3.6 Gain Adjustment of Speed Loop

Here introduces the function of speed control unit. The following shows its structure.

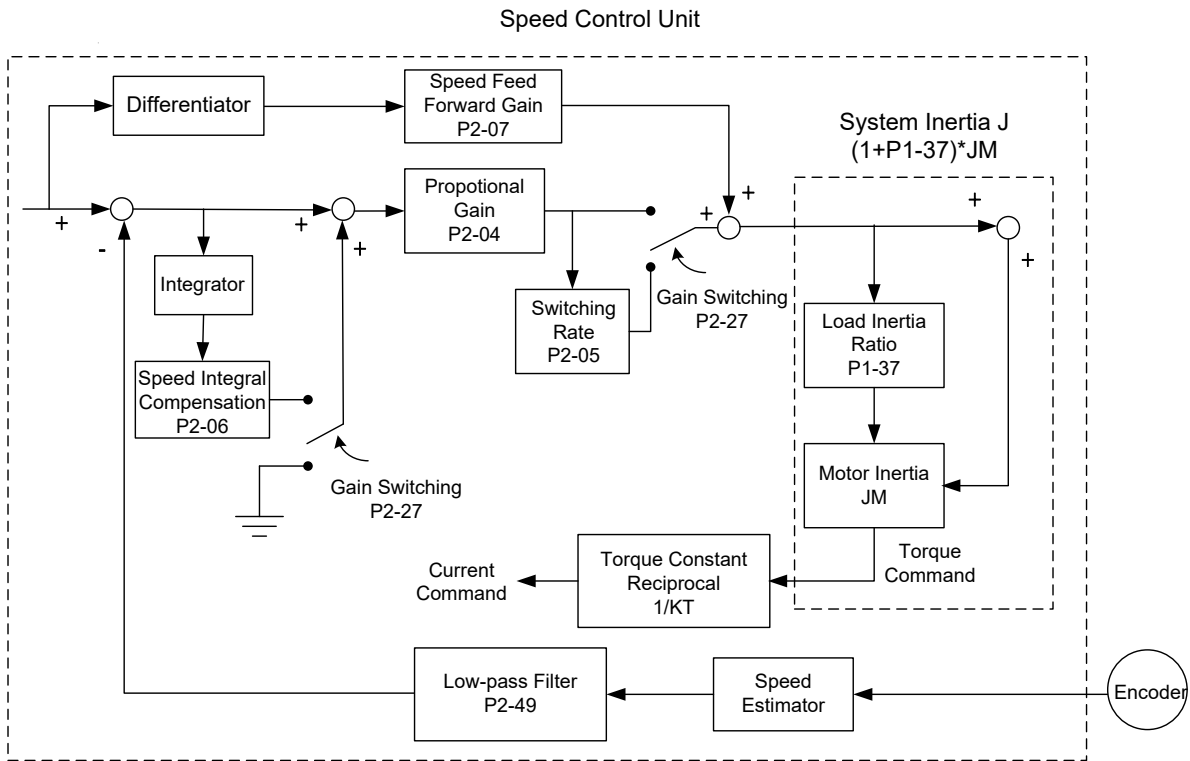

Many kinds of gain in speed control unit are adjustable. Two ways, manual and auto, are provided for selection.

Manual: All parameters are set by users and the auto or auxiliary function will be disabled in this mode.

Auto: General load inertia estimation is provided. It adjusts the parameter automatically. Its framework is divided into PI auto gain adjustment and PDFF auto gain adjustment.

Parameter P2-32 can be used to adjust the gain.

P2-32 ▲	AUT2	Tuning Mode Selection		Address: 0240H 0241H
Operational Interface :	Panel / Software	Communication		Related Section: 5.6 and 6.3.6
Default :	0x0000			
Control Mode :	ALL			
Unit :	-			
Range :	0x0000 ~ 0x0002			

Data Size :	16-bit
Format :	Hexadecimal

Settings: 0: Manual Mode

1: Auto Mode (continuous adjustment)

2: Semi-auto Mode (non-continuous adjustment)

Relevant description of manual mode setting:

When P2-32 is set to 0, parameters related to gain control, such as P2-00, P2-04, P2-06, P2-07, P2-25, and P2-26, all can be set by the user.

When switching mode from auto or semi-auto to manual, parameters about gain will be updated automatically.

Relevant description of auto mode setting:

Continue to estimate the system inertia, save the inertia ratio to P1-37 every 30 minutes automatically and refer to the stiffness and bandwidth setting of P2-31.

1. Set the system to manual mode 0 from auto 1 or semi-auto 2, the system will save the estimated inertia value to P1-37 automatically and set the corresponding parameters.
2. Set the system to auto mode 1 or semi-auto mode 2 from manual mode 0, please set P1-37 to the appropriate value.
3. Set the system to manual mode 0 from auto mode 1, P2-00, P2-04, P2-06, P2-25, P2-26, and P2-49 will be modified to the corresponding parameters of auto mode.
4. Set the system to manual mode 0 from semi-auto mode 2, P2-00, P2-04, P2-06, P2-25, P2-26, and P2-49 will be modified to the corresponding parameters of semi-auto mode.

Relevant description of semi-auto mode setting:

1. When the system inertia is stable, the value of P2-33 will be 1 and the system stops estimating. The inertia value will be saved to P1-37 automatically. When switching mode to semi-auto mode (from manual or auto mode), the system starts to estimate again.
2. When the system inertia is over the range, the value of P2-33 will be 0 and the system starts to estimate and adjust again.

Manual Mode

When P2-32 is set to 0, users can define Speed Loop Gain (P2-04), Speed Integral Compensation (P2-06), and Speed Feed Forward Gain (P2-07). Influence of each parameter is as the followings.

Proportional gain: To increase proportional gain can enhance the response bandwidth of speed loop.

Integral gain: To increase the integral gain could increase the low-frequency stiffness of speed loop, reduce the steady-state error and sacrifice the phase margin. The overhigh integral gain will cause the instability of the system.

Feed forward gain: Diminish the deviation of phase delay.

Related parameters:

P2-04	KVP	Speed Loop Gain		Address: 0208H 0209H
Operational Interface :	Panel / Software	Communication		Related Section: 6.3.6
Default :	500			
Control Mode :	ALL			
Unit :	rad/s			
Range :	0 ~ 8191			
Data Size :	16-bit			
Format :	Decimal			

Settings : Increasing the value of speed loop gain can enhance the speed response. However, if the value is set too big, it would easily cause resonance and noise.

P2-06	KVI	Speed Integral Compensation		Address: 020CH 020DH
Operational Interface :	Panel / Software	Communication		Related Section: 6.3.6
Default :	100			
Control Mode :	ALL			
Unit :	rad/s			
Range :	0 ~ 1023			
Data Size :	16-bit			
Format :	Decimal			

Settings : Increasing the value of speed integral compensation can enhance speed response and diminish the deviation of speed control. However, if the value is set too big, it would easily cause resonance and noise.

P2-07	KVF	Speed Feed Forward Gain		Address: 020EH 020FH
Operational Interface :	Panel / Software	Communication	Related Section: 6.3.6	
Default :	0			
Control Mode :	ALL			
Unit :	%			
Range :	0 ~ 100			
Data Size :	16-bit			
Format :	Decimal			

Settings : When the speed control command runs smoothly, increasing the gain value can reduce the speed following error. If the command does not run smoothly, decreasing the gain value can reduce the mechanical vibration during operation.

Theoretically, stepping response can be used to explain proportional gain (KVP), integral gain (KVI), and feed forward gain (KVF). Here, the frequency domain and time domain are used to illustrate the basic principle.

Frequency Domain

STEP 1: Set the value of KVI=0, the value of KVF=0 and adjust the value of KVP.

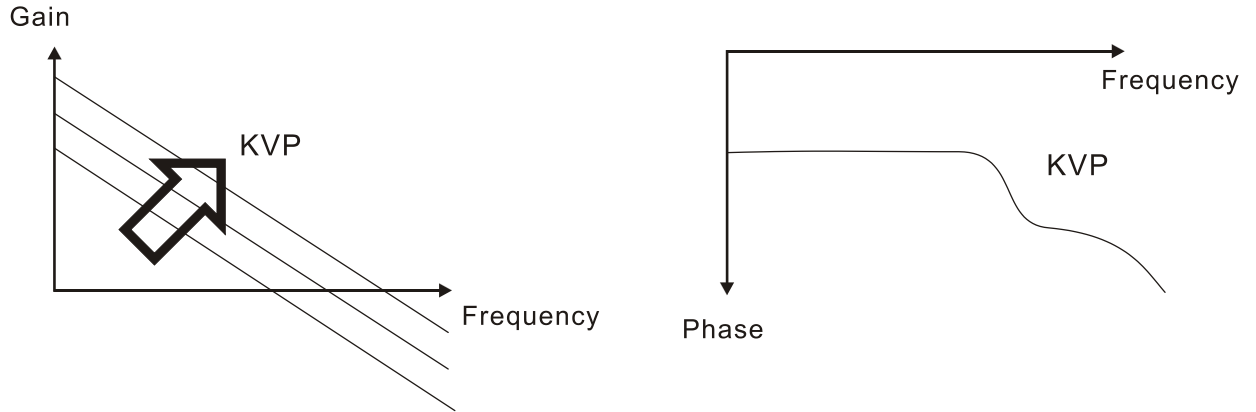

STEP 2 : Fix the value of KVP and adjust the value of KVI.

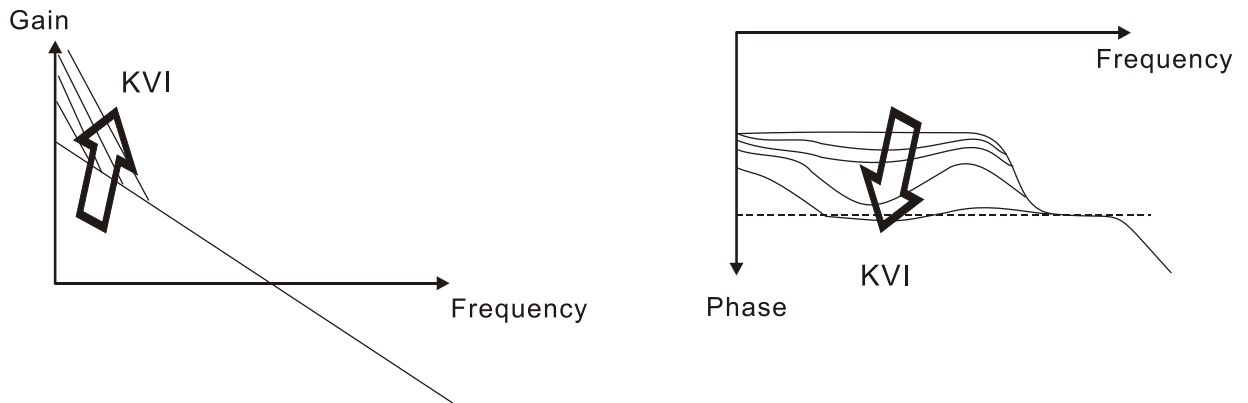

STEP 3 : Select the value of KVI, if the value of phase margin is too small, re-adjust the value of KVP again to obtain the value, 45deg of phase margin.

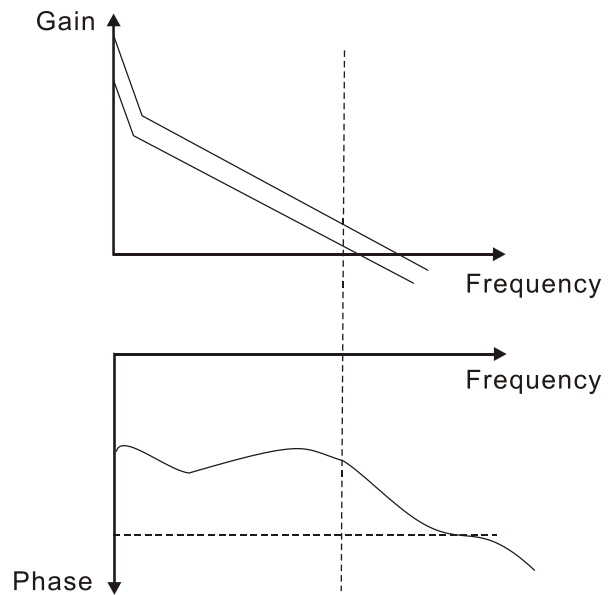

Time Domain

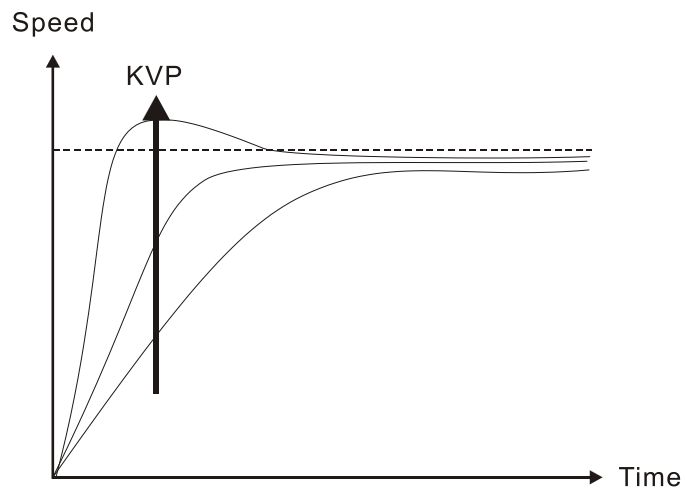

The bigger KVP value causes higher bandwidth and shortens the rising time. However, if the value is set too big, the phase margin will be too small.

To steady-state error, the result is not as good as KVI. But it helps to reduce the dynamic following error.

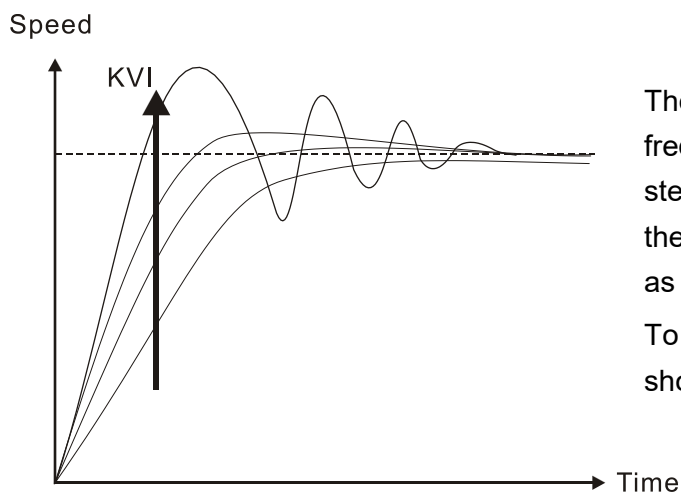

The bigger KVI value causes greater low-frequency gain and shortens the time the steady-state error returns to zero. However, the phase margin will dramatically decrease as well.

To steady-state error, it is very helpful but shows no benefit to dynamic following error.

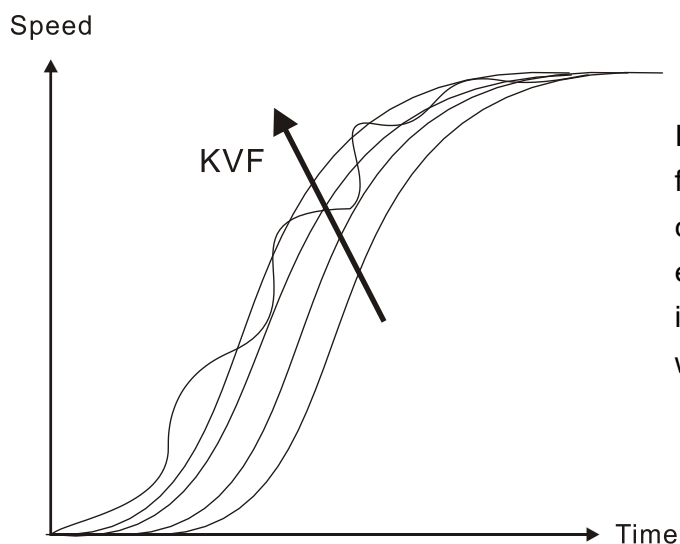

If the KVF value closes to 1, the feed forward compensation will be more complete and the dynamic following error will become smaller. However, if the KVF value is set too big, it would cause vibration.

Generally, instrument is needed when applying frequency domain for measurement. Users are required to adopt the measurement techniques; while time domain only needs a scope and goes with the analog input/output terminal provided by the servo drive. Thus, time domain is frequently used to adjust PI controller. The abilities of PI controller to deal with the resistance of torque load and the following command are the same. That is to say, the following command and resistance of torque load have the same performance in frequency domain and time domain. Users can reduce the bandwidth by setting the low-pass filter in command end.

Auto Mode

Auto mode adopts adaptive principle. The servo drive automatically adjusts the parameters according to the external load. Since the adaptive principle takes longer time, it will be unsuitable if the load changes too fast. It would be better to wait until the load inertia is steady or changes slowly. Depending on the speed of signal input, the adaptive time will be different from one another.

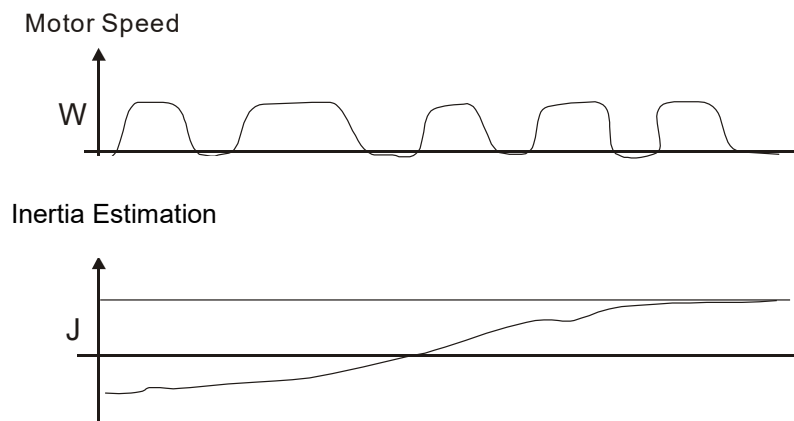

6.3.7 Resonance Suppression

When resonance occurs, it is probably because the stiffness of the control system is too strong or the response bandwidth is too fast. Eliminating these two factors might improve the situation. In addition, low-pass filter (parameter P2-25) and notch filter (parameter P2-23 and P2-24) are provided to suppress the resonance if not changing the control parameters.

Related parameters:

P2-23	NCF1	Resonance Suppression (Notch filter) (1)		Address: 022EH 022FH
Operational Interface :	Panel / Software	Communication	Related Section: 6.3.7	
Default :	1000			
Control Mode :	ALL			
Unit :	Hz			
Range :	50 ~ 1000			
Data Size :	16-bit			
Format :	Decimal			

Settings : The first setting value of resonance frequency. If P2-24 is set to 0, this function is disabled. P2-43 and P2-44 are the second Notch filter.

P2-24	DPH1	Resonance Suppression (Notch filter) Attenuation Rate (1)		Address: 0230H 0231H
Operational Interface :	Panel / Software	Communication	Related Section: 6.3.7	
Default :	0			
Control Mode :	ALL			
Unit :	-dB			
Range :	0 ~ 32 (0: disable the function of Notch filter)			
Data Size :	16-bit			
Format :	Decimal			

Settings : The first resonance suppression (notch filter) attenuation rate. When this parameter is set to 0, the function of Notch filter is disabled.

Note : If the value of attenuation rate is set to 5, then, it would be -5 dB.

P2-43	NCF2	Resonance Suppression (Notch filter) (2)		Address: 0256H 0257H
	Operational Interface :	Panel / Software	Communication	Related Section: 6.3.7
	Default :	1000		
	Control Mode :	ALL		
	Unit :	Hz		
	Range :	50 ~ 2000		
	Data Size :	16-bit		
	Format :	Decimal		

Settings : The second setting value of resonance frequency. If P2-44 is set to 0, this function is disabled. P2-23 and P2-24 are the first Notch filter.

P2-44	DPH2	Resonance Suppression (Notch filter) Attenuation Rate (2)		Address: 0258H 0259H
	Operational Interface :	Panel / Software	Communication	Related Section: 6.3.7
	Default :	0		
	Control Mode :	ALL		
	Unit :	-dB		
	Range :	0 ~ 32 (0: disable Notch filter)		
	Data Size :	16-bit		
	Format :	Decimal		

Settings : The second resonance suppression (notch filter) attenuation rate. When this parameter is set to 0, the function of Notch filter is disabled.

Note: If the value of attenuation rate is set to 5, then it would be -5 dB.

P2-45	NCF3	Resonance Suppression (Notch filter) (3)		Address: 025AH 025BH
	Operation Interface :	Panel / Software	Communication	Related Section: 6.3.7
	Default :	1000		
Control Mode :	ALL			

Unit :	Hz
Range :	50 ~ 2000
Data Size :	16-bit
Format :	DEC

Settings : The third setting value of resonance frequency. If P2-46 is set to 0, this function is disabled. P2-23 and P2-24 are the first Notch filter.

P2-46	DPH3	Resonance Suppression (Notch filter) Attenuation Rate (3)		Address: 025CH 025DH
	Operational Interface :	Panel / Software	Communication	
Default :	0			
Control Mode :	ALL			
Unit :	-dB			
Range :	0 ~ 32			
Data Size :	16-bit			
Format :	Decimal			

Settings : The third group of resonance suppression (Notch filter) attenuation rate. Set the value to 0 to disable the function of Notch filter.

Note: If the value of attenuation rate is set to 5, then it would be -5 dB.

P2-25	NLP	Low-pass Filter of Resonance Suppression		Address: 0232H 0233H
	Operational Interface :	Panel / Software	Communication	
Default :	0.2 (under 1 kW) or 0.5 (other models)	2 (under 1 kW) or 5 (other models)		
Control Mode :	ALL			
Unit :	1 ms	0.1 ms		
Range :	0.0 ~ 100.0	0 ~ 1000		
Data Size :	16-bit			
Format :	One decimal	Decimal		
Example :	1.5 = 1.5 ms	15 = 1.5 ms		

Settings : Set the low-pass filter of resonance suppression. When the value is set to 0, the function of low-pass filter is disabled.

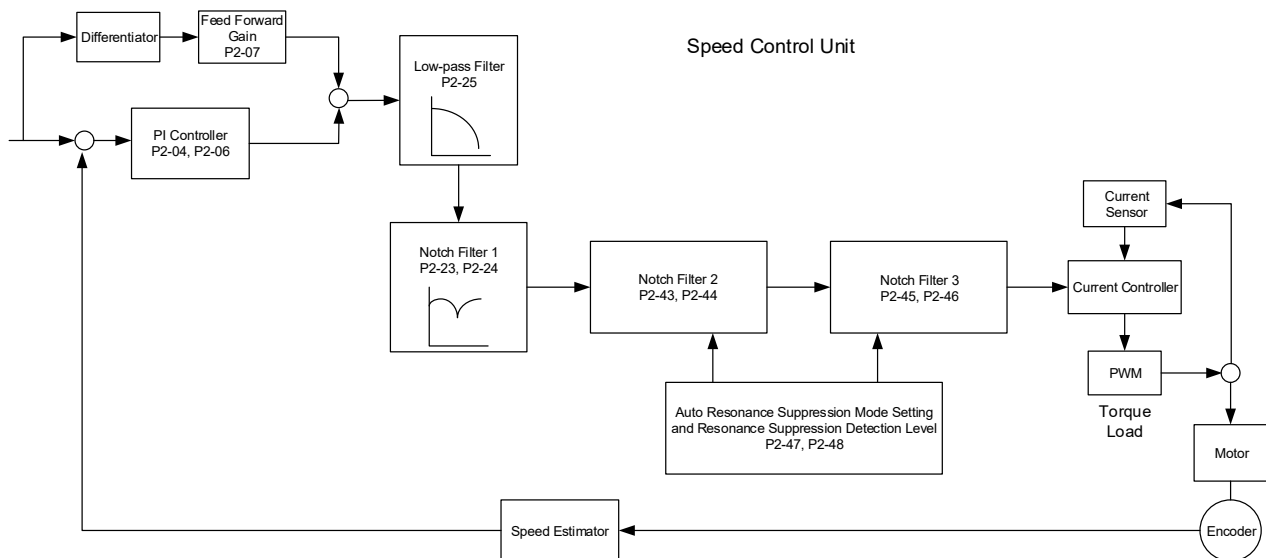

There are two sets of auto resonance suppression, one is P2-43 and P2-44 and the other is P2-45 and P2-46. When the resonance occurs, set P2-47 to 1 or 2 (enable the function of resonance suppression), the servo drive searches the point of resonance frequency and suppresses the resonance automatically. Write the point of frequency into P2-43 and P2-45 and write the attenuation rate into P2-44 and P2-46. When P2-47 is set to 1, the system will set P2-47 to 0 (disable the function of auto suppression) automatically after completing resonance suppression and the system is stable for 20 minutes. When P2-47 is set to 2, the system will keep searching the point of resonance.

When P2-47 is set to 1 or 2, but resonance still exists, please confirm the value of parameter P2-44 and P2-46. If one of them is 32, it is suggested to reduce the speed bandwidth first and then start to estimate again. If the value of both is smaller than 32 and resonance still exists, please set P2-47 to 0 first and then manually increase the value of P2-44 and P2-46. It is suggested to reduce the bandwidth if the resonance has not been improved. Then use the function of auto resonance suppression.

When manually increasing the value of P2-44 and P2-46, please check if the value of both is bigger than 0. If yes, it means the frequency point of P2-43 and P2-45 is the one searched by auto resonance suppression. If the value of both is 0, it means the default, 1000 of P2-43 and P2-45 is not the one searched by auto resonance suppression. Deepen the resonance suppression attenuation rate might worsen the situation.

Settings of P2-47		
Current Value	Desired Value	Function
0	1	Clear the setting value of P2-43 ~ P2-46 and enable auto resonance suppression function.
0	2	Clear the setting value of P2-43 ~ P2-46 and enable auto resonance suppression function.
1	0	Save the setting value of P2-43 ~ P2-46 and disable auto resonance suppression function.
1	1	Clear the setting value of P2-43 ~ P2-46 and enable auto resonance suppression function.
1	2	Do not clear the setting value of P2-43 ~ P2-46 and enable auto resonance suppression function continuously.
2	0	Save the setting value of P2-43 ~ P2-46 and disable auto resonance suppression function.
2	1	Clear the setting value of P2-43 ~ P2-46 and enable auto resonance suppression function.
2	2	Do not clear the setting value of P2-43 ~ P2-46 and enable auto resonance suppression function continuously.

Flowchart of Auto Resonance Suppression:

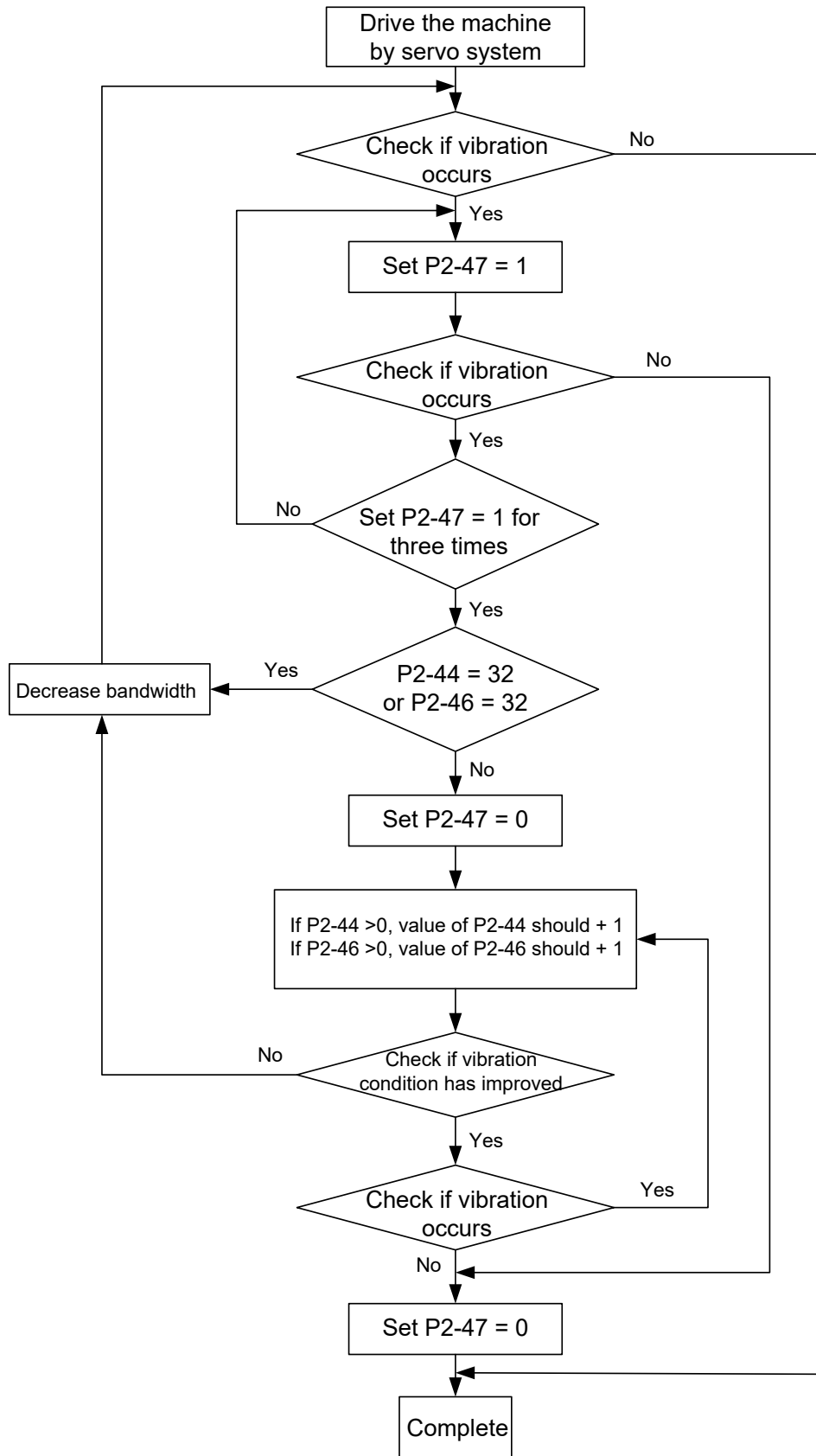

Here illustrates the effect via low-pass filter (parameter P2-25). The following diagram is the system open-loop gain with resonance.

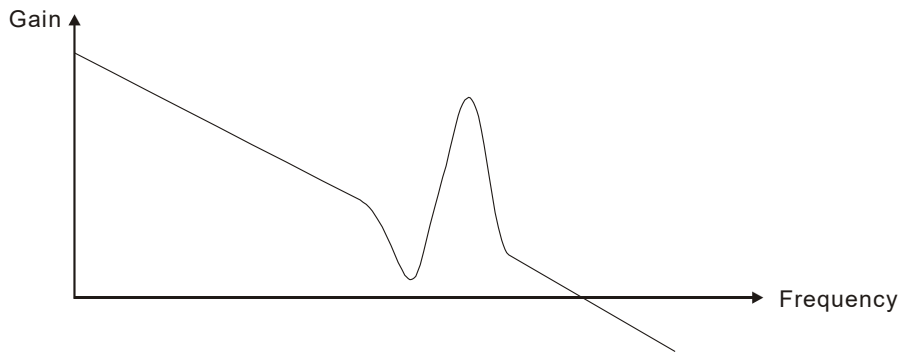

When the value of P2-25 is increased from 0, BW becomes smaller (See as the following diagram). Although it solves the problem of resonance frequency, the response bandwidth and phase margin is reduced.

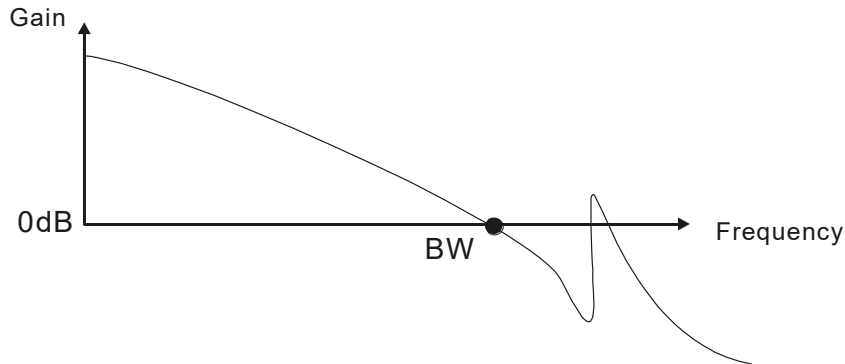

If users know the resonance frequency, notch filter (parameter P2-23 and P2-24) can directly eliminate the resonance. The frequency setting range of notch filter is merely from 50 to 1000 Hz. The suppression strength is from 0 to 32 dB. If the resonance frequency is not within the range, it is suggested to use low-pass filter (parameter P2-25).

Here firstly illustrates the influence brought by notch filter (P2-23 and P2-24) and low-pass filter (P2-25). The following diagrams are the system of open-loop gain with resonance.

Resonance suppression with notch filter

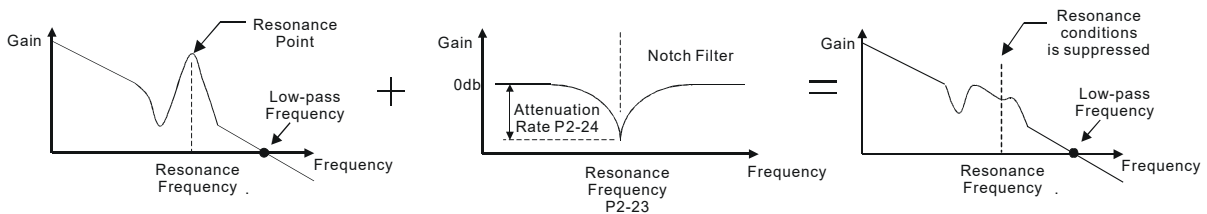

Resonance suppression with low-pass filter

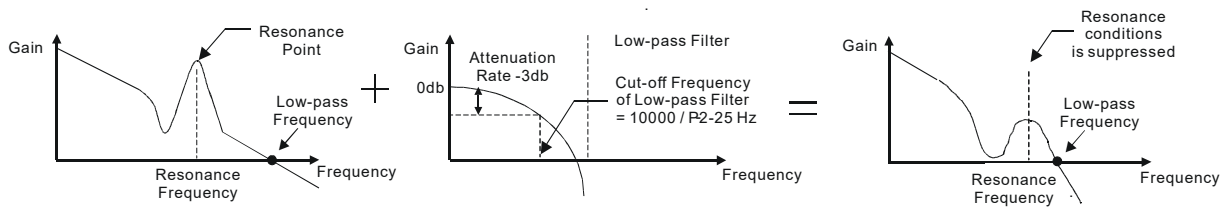

When the value of P2-25 is increased from 0, BW becomes smaller. Although it solves the problem of resonance frequency, the response bandwidth and phase margin is reduced. Also, the system becomes unstable.

If users know the resonance frequency, notch filter (parameters P2-23 and P2-24) can directly eliminate the resonance. In this case, notch filter will be more helpful than low-pass filter. However, if the resonance frequency drifts because of time or other factors, notch filter will not do.

6.4 Torque Mode

Torque control mode (T or Tz) is appropriate in torque control applications, such as printing machine, winding machine, etc. There are two kinds of command source, analog input and register. Analog command input uses external voltage to control the torque of the motor while register uses the internal parameters (P1-12 ~ P1-14) as the torque command.

6.4.1 Selection of Torque Command

Torque command sources are external analog voltage and parameters. It uses CN1 DI signal for selection. See as below.

Torque Command	DI signal of CN1		Command Source		Content	Range
	TCM1	TCM0				
T1	0	0	Mode	T	External analog command Voltage difference between T-REF and GND	-10V ~ +10V
				Tz	None Torque command is 0	0
T2	0	1	Register Parameters		P1-12	-300% ~ 300%
T3	1	0			P1-13	
T4	1	1			P1-14	

- The status of TCM0 ~ TCM1: 0 means DI is OFF and 1 means DI is ON.
- When TCM0 = TCM1 = 0, if it is in Tz mode, then the command is 0. Thus, if there is no need to use analog voltage as torque command, Tz mode is applicable and can avoid the problem of zero drift. If it is in T mode, the command will be the voltage deviation between T-REF and GND. Its input voltage range is -10V ~ +10V, which means the corresponding torque is adjustable (P1-41).
- When neither TCM0 nor TCM1 is 0, parameters become the source of torque command. The command will be executed after TCM0 ~ TCM1 are changed. There is no need to use CTRG for triggering.

The torque command can be used in torque mode (T or Tz) and speed mode (S or Sz). When it is in speed mode, it can be regarded as the command input of torque limit.

6.4.2 Control Structure of Torque Mode

The basic control structure is as the following diagram:

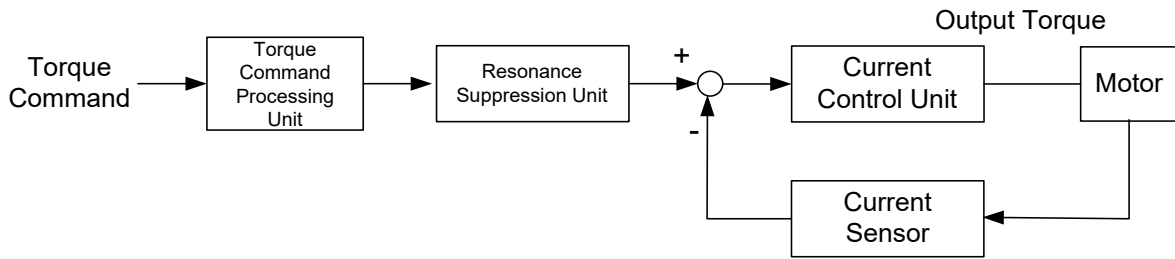

The torque command processing unit is to select torque command source according to Section 6.4.1, including the scaling (P1-41) setting and S-curve setting. The current control unit manages the gain parameters of the servo drive and calculates the current for servo motor in time. Since the current control unit is very complicated and is not relevant to the application, there is no need to adjust parameters. Only command end setting is provided.

The structure of torque command processing unit is as the following diagram.

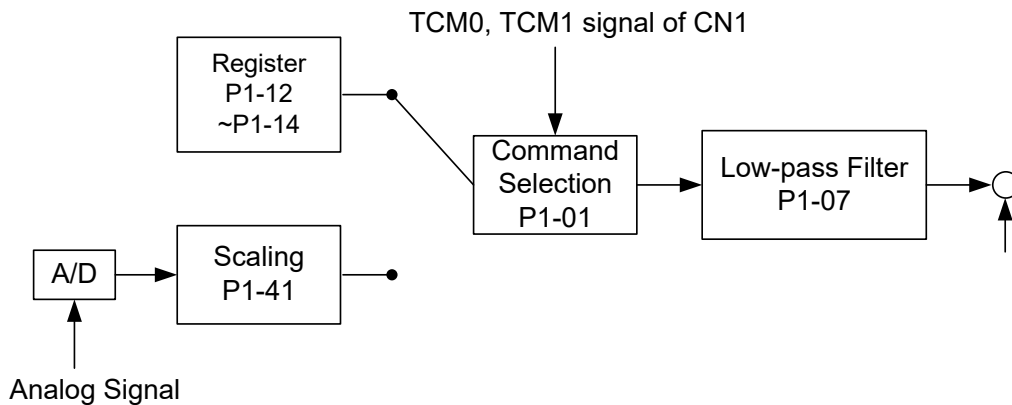

The upper path is the command from register while the lower one is external analog command. The command is selected according to the status of TCM0, TCM1 and P1-01 (T or Tz). The torque represented by analog voltage command can be adjusted via the scaling and can obtain a smoother response via low-pass filter.

6.4.3 Smooth Torque Command

Related parameter:

P1-07	TFLT	Analog Torque Command (Low-pass Filter)		Address: 010EH 010FH
	Operational Interface :	Panel / Software	Communication	Related Section: 6.4.3
	Default :	0		
	Control Mode :	T / Tz		
	Unit :	ms		
	Range :	0 ~ 1000 (0: disable this function)		
	Data Size :	16-bit		
	Format :	Decimal		

Settings : 0: Disabled

6.4.4 The Scaling of Analog Command

The motor torque command is controlled by the analog voltage difference between T_REF and GND and goes with parameter P1-41 to adjust the torque slope and its range.

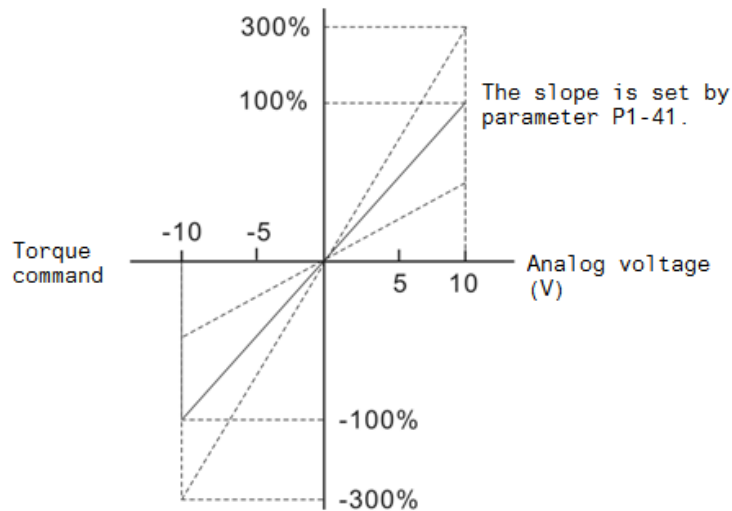

Related parameter:

P1-41 ▲	TCM	Maximum Output of Analog Torque Command	Address: 0152H 0153H
Operational Interface :	Panel / Software	Communication	Related Section: 6.4.4
Default :	100		
Control Mode :	ALL		
Unit :	%		
Range :	0 ~ 1000		
Data Size :	16-bit		
Format :	Decimal		

Settings : Maximum Output of Analog Torque Command:

In torque mode, the analog torque command inputs the torque setting of the max. voltage (10V). When the default setting is 100, if the external voltage inputs 10V, it means the torque control command is 100% rated torque. If the external voltage inputs 5V, then the torque control command is 50% rated torque.

Torque control command = input voltage value x setting value/10 (%)

In speed, PT, and PR mode, the analog torque limit inputs the torque limit setting of the max. voltage (10V).

Torque limit command = input voltage value x setting value/10 (%)

6.4.5 Timing Diagram in Torque Mode

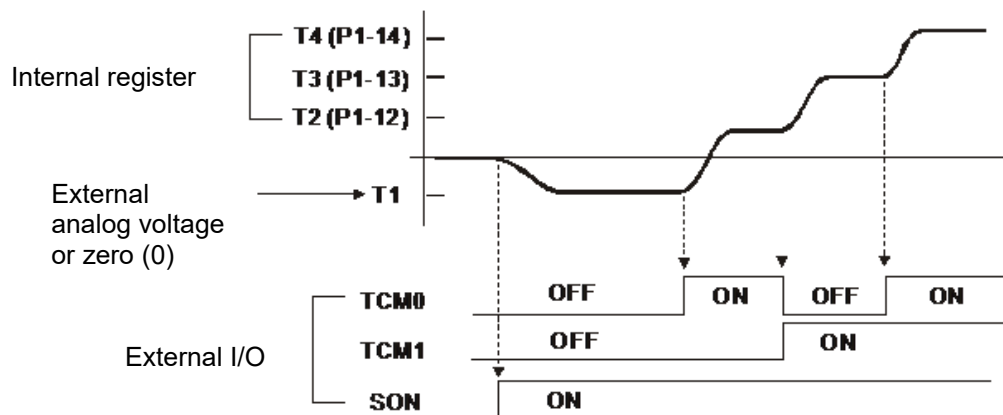

Note:

- 1) OFF means the contact point is open while ON means the contact point is close.
- 2) When it is in Tz mode, the torque command T1 = 0; when it is in T mode, the torque command T1 is the external analog voltage input.
- 3) When it is Servo On, please select the command according to TCM0 ~ TCM1 status.

6.5 Dual Mode

Apart from single mode, dual mode is also provided for operation. According to Section 6.1, dual modes are as followings:

1. Speed / position dual mode (PT-S, PR-S, PT-PR)
2. Speed / torque dual mode (S-T)
3. Torque / position dual mode (PT-T, PR-T)
4. Position speed multiple mode (PT-PR-S)
5. Position torque multiple mode (PT-PR-T)

Mode Name	Short Name	Setting Code	Description
Dual Mode	PT-S	06	PT and S can be switched via DI signal, S_P .
	PT-T	07	PT and T can be switched via DI signal, T_P .
	PR-S	08	PR and S can be switched via DI signal, S_P .
	PR-T	09	PR and T can be switched via DI signal, T_P .
	S-T	0A	S and T can be switched via DI signal, S_T .
	PT-PR	0D	PT and PR can be switched via DI signal, PT_PR .
Multiple Mode	PT-PR-S	0E	PT , PR , and S can be switched via DI signal, S_P and PT_PR .
	PT-PR-T	0F	PT , PR , and T can be switched via DI signal, T_P and PT_PR .

Sz and Tz dual mode is not provided here. For avoiding occupying too many digital inputs in dual mode, speed and torque mode can use external analog voltage as the command source so as to reduce digital input (SPD0, SPD1 or TCM0, TCM1). Please refer to Section 3.4.2, Table 3.1, Default Value of DI Input Function and Table 3.2, Default Value of DO Output Function for the default DI/DO of each mode.

The relationship between DI/DO signals and PIN definition are set after the mode is selected. If users desire to change the setting, please refer to section 3.4.4.

6.5.1 Speed / Position Dual Mode

There are PT-S and PR-S in speed/position dual mode. The command source of the former one comes from external pulse while the latter one comes from internal parameters (P6-00 ~ P7-27). Speed command could be issued by external analog voltage or internal parameters (P1-09 ~ P1-11). The switch of speed/position mode is controlled by S-P signal and the switch of PR-S mode is controlled by DI signal, which is more complicated. The timing diagram is shown as below.

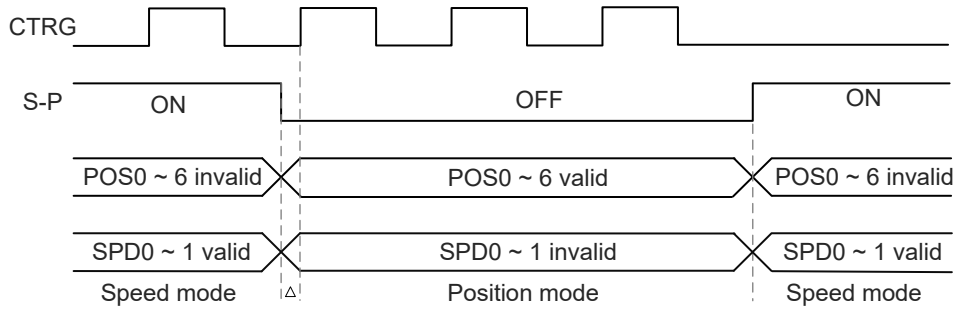

In speed mode (S-P is ON), the speed command is selected via SPD0 and SPD1. CTRG is not working at the moment. When switching to position mode (S-P is OFF), since position command has not been issued (needs to wait the rising edge of CTRG), the motor stops. The position command is determined by POS0 ~ POS5 and triggered by rising edge of CTRG, and the motor moves towards that position immediately. When S-P is ON, it goes back to speed mode again. Please refer to the introduction of single mode for DI signal and the selected command of each mode.

6.5.2 Speed / Torque Dual Mode

S-T is the only mode. The speed command comes from the external analog voltage and internal parameters (P1-09 ~ P1-11), which is selected via SPD0 ~ SPD1. Similarly, the source of torque command could be external analog voltage and internal parameters (P1-12 ~ P1-14) and is selected via TCM0 ~ TCM1. The switch of speed/torque mode is controlled by S-T signal. The timing diagram is shown as below.

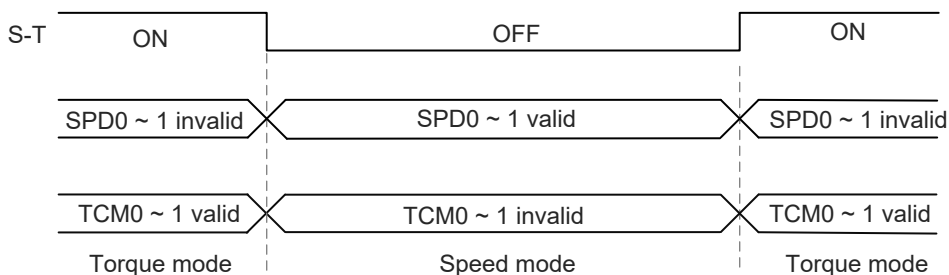

In torque mode (S-T is ON), the torque command is selected via TCM0 and TCM1. When switching to speed mode (S-T is OFF), the torque command is selected via SPD0 and SPD1. The motor operates according to the speed command. When S-T is ON, it goes back to the torque mode again. Please refer to the introduction of single mode for DI signal and the selected command of each mode.

6.5.3 Torque / Position Dual Mode

There are PT-T and PR-T in speed/position dual mode. The command source of the former one comes from external pulse while the latter one comes from internal parameters (P6-00 ~ P7-27). Torque command could be issued by external analog voltage or internal parameters (P1-12 ~ P1-14). The switch of torque/position mode is controlled by T-P signal and the switch of PR-T mode is controlled by DI signal, which is more complicated. The timing diagram is shown as below.

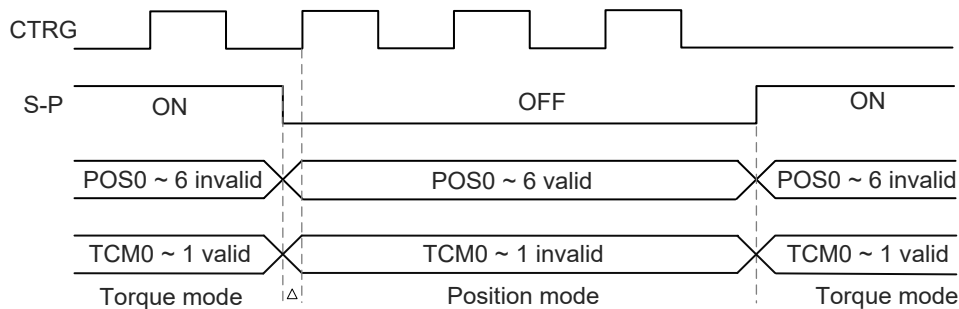

In torque mode (T-P is ON), the torque command is selected via TCM0 and TCM1. CTRG is not working at the moment. When switching to position mode (T-P is OFF), since position command has not been issued (needs to wait the rising edge of CTRG), the motor stops. The position command is determined by POS0 ~ POS5 and triggered by rising edge of CTRG, and the motor moves towards that position immediately. When T-P is ON, it goes back to torque mode again. Please refer to the introduction of single mode for DI signal and the selected command of each mode.

6.6 Others

6.6.1 The Use of Speed Limit

The maximum speed in each mode is limited by internal parameter (P1-55), not matter it is in position, speed, or torque mode.

The issuing method of speed limit command and speed command is the same. The command source could be external analog voltage or internal parameters (P1-09 ~ P1-11). Please refer to Section 6.3.1 for descriptions.

Speed limit can be used in torque mode (T) only. It is used for limiting the motor speed. When the command in torque mode is issued by external analog voltage, DI signal is enough and can be regarded as SPD0 ~ SPD1, which is used to determine the speed limit command (internal parameters). If the DI signal is not enough, speed limit command can be issued by analog voltage. When the disable/enable limit function in P1-02 is set to 1, the speed limit function is enabled. See the timing diagram as below.

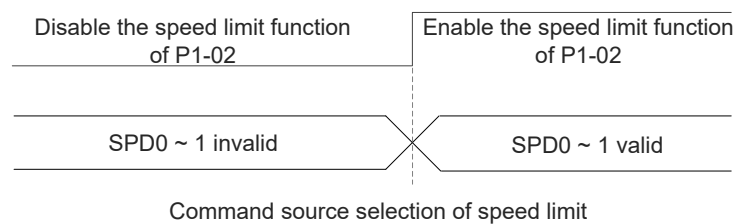

6.6.2 The Use of Torque Limit

The issuing method of torque limit command and torque command is the same. The command source could be external analog voltage or internal parameters (P1-12 ~ P1-14). Please refer to section 6.4.1 for descriptions.

Torque limit can be used in position mode (PT, PR) or speed mode (S). It is used for limiting the motor torque output. When the command in position mode is issued by external pulse or the command in speed mode is issued by external analog voltage, DI signal is enough and can be regarded as TCM0 ~ TCM1, which is used to determine torque limit command (internal parameters). If the DI signal is not enough, torque limit command can be issued by analog voltage. When the disable/enable torque limit function in P1-02 is set to 1, the torque limit function is enabled. See the timing diagram as below.

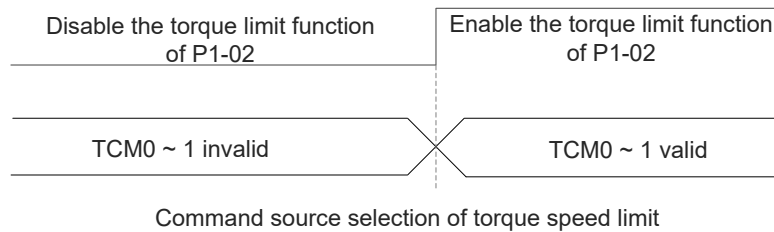

6.6.3 Analog Monitor

Users could observe the needed voltage signal via analog monitor. Two analog channels are provided by the servo drive and located in terminal 15 and 16 of CN1. The related parameter settings are as the followings.

P0-03	MON	Analog Output Monitor		Address: 0006H 0007H
	Operational Interface :	Panel / Software	Communication	Related Section: 4.3.5
	Default :	0x0000		
	Control Mode :	ALL		
	Unit :	-		
	Range :	0x0000 ~ 0x0077		
	Data Size :	16-bit		
	Format :	Hexadecimal		

Settings :

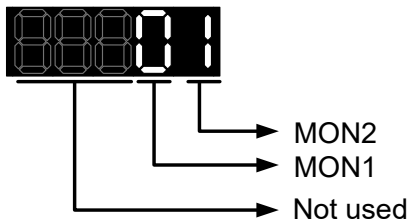

MON1, MON2 Setting Value	Description
0	Motor speed (+/-8 Volts/Max. speed)
1	Motor torque (force) (+/-8 Volts/Max. torque (force))
2	Pulse command frequency (+8 Volts / 4.5 Mpps)
3	Speed command (+/-8 Volts/ Max. speed command)
4	Torque (force) command (+/-8 Volts/Max. torque (force) command)
5	VBUS voltage (+/-8 Volts / 450V)
6	Reserved
7	Reserved

Note: Please refer to parameter P1-04 and P1-05 for proportional setting of analog output voltage.

For example: P0-03 = 01 (MON1 is the analog output of motor speed; MON2 is the analog output of motor torque (force))

$$\text{MON1 output voltage} = 8 \times \frac{\text{Motor speed}}{(\text{Max. speed} \times \frac{P1-04}{100})} \text{ (unit: Volts)}$$

$$\text{MON2 output voltage} = 8 \times \frac{\text{Motor torque}}{(\text{Max. torque} \times \frac{P1-05}{100})} \text{ (unit: Volts)}$$

P1-03	AOUT	Polarity Setting of Encoder Pulse Output		Address: 0106H 0107H
	Operational Interface :	Panel / Software	Communication	Related Section: 3.3.3
	Default :	0x0000		
	Control Mode :	ALL		
	Unit :	-		
	Range :	0x0000 ~ 0x0013		
	Data Size :	16-bit		
	Format :	Hexadecimal		

Settings :

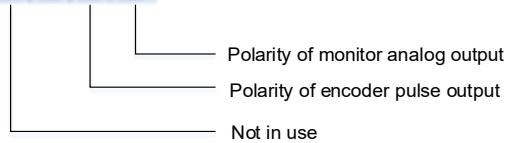

- Polarity of monitor analog output
 - 0: MON1(+), MON2(+)
 - 1: MON1(+), MON2(-)
 - 2: MON1(-), MON2(+)
 - 3: MON1(-), MON2(-)
- Polarity of encoder pulse output
 - 0: Forward output
 - 1: Reverse output

P1-04	MON1	MON1 Analog Monitor Output Proportion		Address: 0108H 0109H
	Operational Interface :	Panel / Software	Communication	Related Section: 6.4.4
Default :	100			

Control Mode :	ALL
Unit :	% (full scale)
Range :	0 ~ 100
Data Size :	16-bit
Format :	Decimal

Settings : Please refer to parameter P0-03 for the setting of analog output selection.

For example:

P0-03 = 0x0 (MON1 is the speed analog output)

When the output voltage value of MON1 is V1:

Motor speed = (Max. speed × V1/8) × P1-04/100

P1-05	MON2	MON2 Analog Monitor Output Proportion		Address: 0108H 0109H
	Operational Interface :	Panel / Software	Communication	Related Section: 6.4.4
	Default :	100		
	Control Mode :	ALL		
	Unit :	% (full scale)		
	Range :	0 ~ 100		
	Data Size :	16-bit		
	Format :	Decimal		

Settings : Please refer to parameter P0-03 for the setting of analog output selection.

For example:

P0-03 = 0x (MON2 is the speed analog output)

When the output voltage value of MON2 is V2:

Motor speed = (Max. × V2/8) × P1-05/100

P4-20	DOF1	Offset Adjustment Value of Analog Monitor Output (Ch1)		Address: 0428H 0429H
	Operational Interface :	Panel / Software	Communication	Related Section: 6.4.4
	Default :	0		
Control Mode :	ALL			

Unit :	mV
Range :	-800 ~ 800
Data Size :	16-bit
Format :	Decimal

Settings : Offset adjustment value (cannot reset). The calibration function needs to be enabled by P2-08.

P4-21	DOF2	Offset Adjustment Value of Analog Monitor Output (Ch2)		Address: 042AH 042BH
	Operational Interface :	Panel / Software	Communication	Related Section: 6.4.4
	Default :	0		
	Control Mode :	ALL		
	Unit :	mV		
	Range :	-800 ~ 800		
	Data Size :	16-bit		
	Format :	Decimal		

Settings : Offset adjustment value (cannot reset). The calibration function needs to be enabled by P2-08.

For example, if users desire to observe the voltage signal in channel 1, when the pulse command frequency 325 Kpps corresponds to 8V output voltage, users need to adjust the monitor output proportion of P1-04 to 50 (= 325 Kpps/ Max. input frequency). Other related settings include P0-03 (X= 3) and P1-03 (The polarity setting range of monitor analog output is between 0 and 3, and it can set positive/negative polarity output). Generally speaking, the output voltage of Ch1 is V_1 ; the pulse command frequency is $(\text{Max. input frequency} \times V_1/8) \times P1-04/100$.

Because of the offset value, the zero voltage level of analog monitor output does not match to the zero point of the setting. This can be improved via the setting of offset adjustment value of analog monitor output, DOF1 (P4-20) and DOF2 (P4-21). The voltage level of analog monitor output is $\pm 8V$, if the output voltage exceeds the range, it will be limited within $\pm 8V$. The provided resolution is about 10 bits, which equals to 13 mV/LSB.

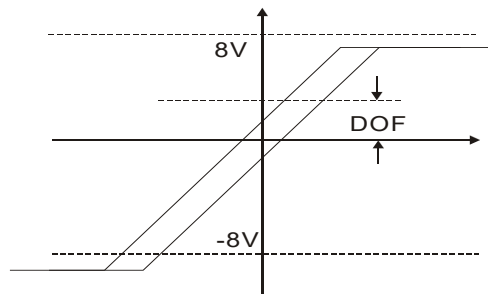

6.6.4 The Use of Brake

When operating brake via servo drive, if the DO signal, BRKR, is set to OFF, it means the brake is not working and the motor will be locked. If BRKR is set to ON, it means the brake is working and the motor can operate. The operation of brake has two kinds. Users can set the relevant delay time with registers MBT1 (P1-42) and MBT2 (P1-43).

To avoid the mechanism from falling down, the magnetic brake is usually used to output an upward force in the Z-axis direction so as to prevent the servo motor's continuous resistance which leads to the overheat and shorter lifetime of the motor. In order to avoid the error of brake, it must be worked when the servo drive is off.

Timing diagram of brake control:

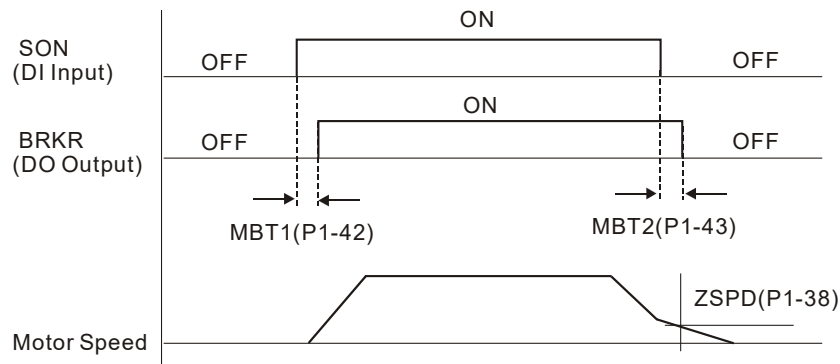

The output timing of BRKR:

1. When Servo Off, when the time set by P1-43 is exceeded and the motor speed is faster than the setting in P1-38, DO.BRKR is OFF (the brake is locked).
2. When Servo Off, when the time set by P1-43 is not yet reached but the motor speed is slower than the setting in P1-38, DO.BRKR is OFF (the brake is locked.).

The wiring diagram of using magnetic brake:

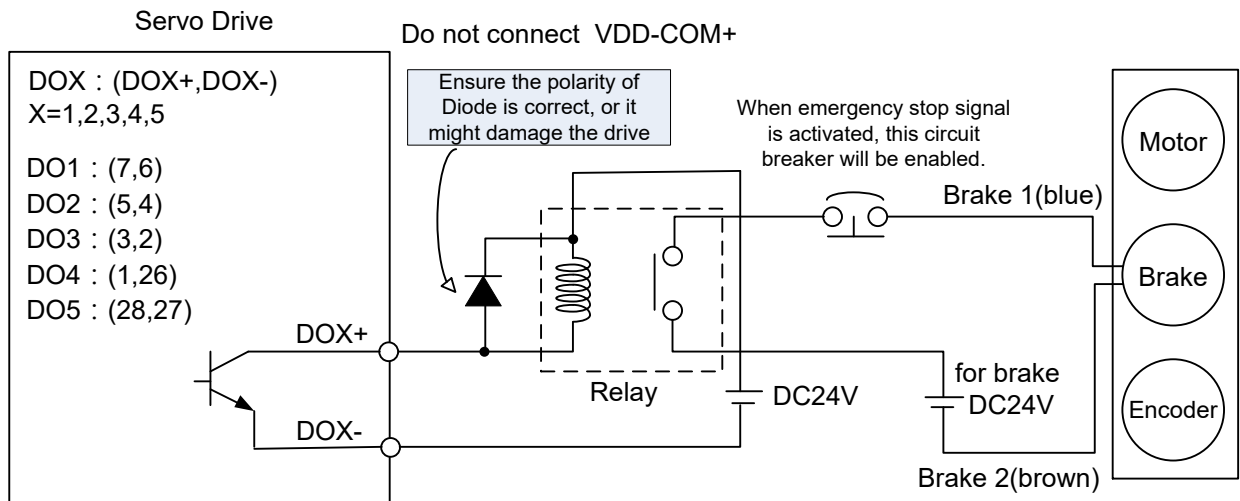

Note:

- 1) Please refer to Chapter 3, Wiring.
- 2) The brake signal controls the solenoid valve, provides power to the brake, and enables the brake.
- 3) Please note that the brake coil has no polarity.
- 4) Do not use brake power and control power (VDD) at the same time.

Timing diagram of control power and main power:

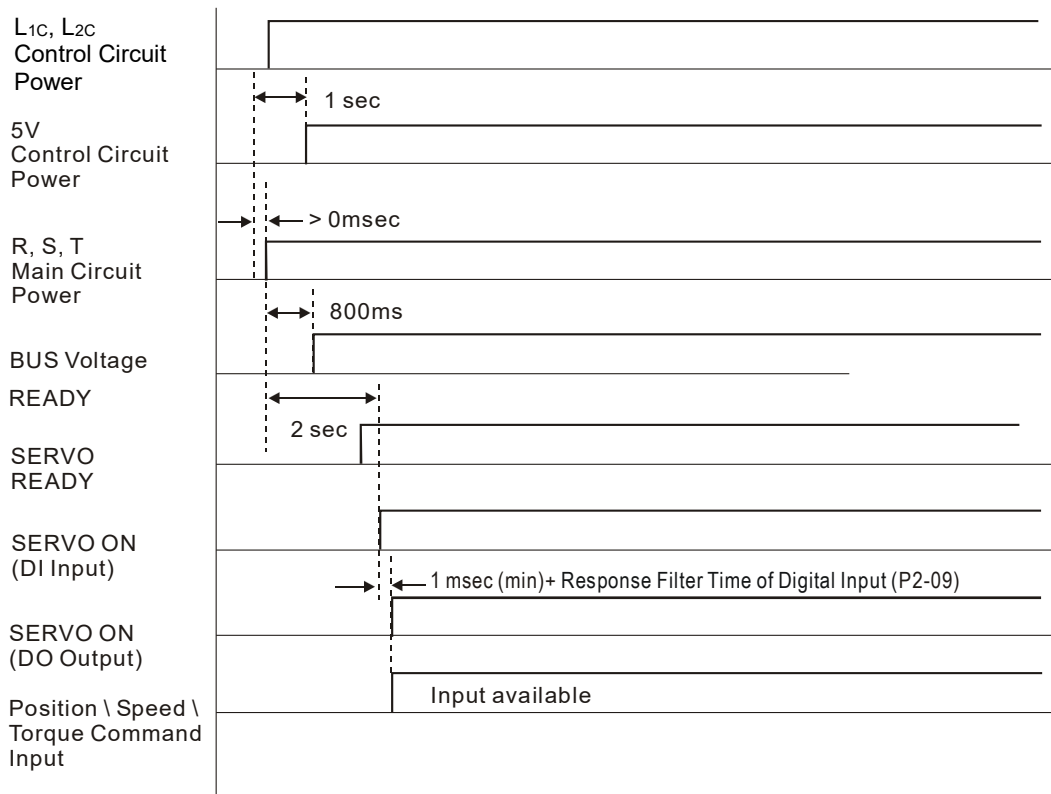

(This page is intentionally left blank.)

Chapter 7 Motion Control

7.1 Motion Control Functions of ASDA-A2

- 1) Single-axis motion controller of PR (Procedure) control
- 2) Function of Capture (data capture) / Compare (data compare)
- 3) Electronic Cam (E-Cam) function (ASDA-A2 series L type models do not support this function.)

7.2 System Information

The information of the servo drive can be divided into three parts: System parameters, Monitoring variables, and Data array.

Descriptions are as follows:

	System Parameters	Monitoring variables
Functional Description	It is used to be the reference mode, important data, or operation condition when the servo drive is operating, e.g. Control Mode, Servo Loop Gain, etc.	The status of the servo drive or motor, e.g. motor position, speed, electric current, etc.
Display Format	The panel displays PX-XX. Pressing the SET Key to display parameters and start setting. Please refer to Chapter 4 for Panel Display and Operation.	Set P0-02 to Monitoring variables code and enter Monitoring Mode. The panel will display the value of the variable. Or press the MODE Key on the panel to switch to Monitoring Mode. Please refer to Chapter 4 for Panel Display and Operation.
Access Method	Readable and writable (depends on parameters)	Read-only
Data Size	16-bit or 32-bit (depends on parameters)	32-bit integers only
Communication	Access via MODBUS / CANopen / USB. Each parameter occupies two MODBUS addresses.	<ul style="list-style-type: none"> ● It can only be monitored by connecting to PC software with USB. ● It does not directly support MODBUS / CANopen access, unless mapping is for corresponding the specified monitoring variables to system parameters.
Mapping Support	8 groups of parameter, P0-25 ~ P0-32 (set by P0-35 ~ P0-42).	5 groups of parameter, P0-09 ~ P0-13 (set by P0-17 ~ P0-21).

	System Parameters	Monitoring variables
Note		In Monitoring Mode, pressing the UP / DOWN keys on the panel to switch the commonly used monitoring variables (code 0 ~ 26); however, it cannot display all (about 150 in total).

7.2.1 Description of Monitoring Variables

Description of monitoring variables:

Item	Descriptions
Variable Code	Each monitoring variable has a code. Set the code via P0-02 so that the users can monitor the variable.
Format	Every monitoring variable is saved with the format of 32-bit (long integer) in the servo drive.
Classification	They are divided into basic variables and expansion variables: <ol style="list-style-type: none"> Basic variables: Use the Monitoring Mode on the panel to find the variable (variables in the cycle) by pressing the UP / DOWN Key (P0-02 = 0 ~ 26) Expansion variables: Variables other than the basic ones (P0-02 = 27 ~ 127)
Monitor Method	Two methods, Panel display and Mapping: <ol style="list-style-type: none"> Panel display: View through the panel directly. Mapping: Correspond the variables to the system parameters and view the variables via parameters.
Panel Display	<ol style="list-style-type: none"> Switch to the Monitoring Mode by pressing the MODE Key and select the desired monitoring variables via the UP / DOWN Key. Directly enter the desired monitoring code via P0-02 for viewing. Pressing the SHF Key on the panel can switch the display of high / low word; pressing the SET Key on the panel can switch the display of decimal / hexadecimal format.
Mapping	<ol style="list-style-type: none"> Mapping parameters that support monitoring variables are P0-09 ~ P0-13. Please refer to section 8.3 for parameter description. Monitoring variables can be read via communication by mapping parameters. The value of mapping parameters (P0-09 ~ P0-13) is the content of basic variables (17h, 18h, 19h, 1Ah). To monitor P0-09, set P0-17 to the value to read (refer to P0-02). When accessing data via communication, the value of P0-17 can be read or monitored via the panel (set P0-02 to 23). When the panel shows "VAR-1," it means it is the value of P0-09.

The descriptions of monitoring variables attribute are as follows.

Attribute	Descriptions
B	BASE: basic variables. Variables that can be viewed by UP/DOWN Key on the panel.
Dn	When the panel displays, the position of the decimal point will be D1 which means it only shows one decimal point; D2 means it shows two decimal points.
Dec	When the panel displays, the information only can be shown in decimal format. Pressing the SET Key on the panel cannot switch it to hexadecimal format.
Hex	When the panel displays, the information only can be shown in hexadecimal format. Pressing the SET Key on the panel cannot switch it to decimal format.

Explanation of monitoring variables:

Code	Name of Variables / Attribute	Descriptions
000 (00h)	Feedback position (PUU) B	The current feedback position of the motor encoder. The unit is PUU (user unit).
001 (01h)	Position command (PUU) B	The current coordinate of position command. The unit is PUU (user unit). PT mode: it represents the pulse number the servo drive received. PR mode: the value of absolute coordinate from position command Equals to the pulse number sent by the controller.
002 (02h)	Position deviation (PUU) B	The deviation between the position command and feedback position. The unit is PUU (user unit).
003 (03h)	Feedback position (pulse) B	Current feedback position of the motor encoder. The unit is pulse (encoder unit).
004 (04h)	Position command (pulse) B	The current coordinate of the position command. The unit is pulse (encoder unit). The command that had gone through E-gear.
005 (05h)	Position deviation (pulse) B	The deviation between the position command and feedback position. The unit is pulse (encoder unit).
006 (06h)	Pulse command frequency B	Frequency of pulse command received by the servo drive. The unit is Kpps. It is suitable in PT/PR mode.
007 (07h)	Speed feedback B D1 Dec	Current speed of the motor. The unit is 0.1 r/min. The value is more stable since it has been through low-pass filter.
008 (08h)	Speed command (analog) B D2 Dec	The speed command is issued from analog channel. The unit is 0.01 Volt.
009 (09h)	Speed command (processed) B	The integrated speed command. The unit is 1 r/min. The source might be analog, register, or position loop.

Code	Name of Variables / Attribute	Descriptions
010 (0Ah)	Torque command (analog) B D2 Dec	The torque command is issued from analog channel. The unit is 0.01 Volt.
011 (0Bh)	Torque command (processed) B	The integrated torque command. The unit is percentage (%). The source might be analog, register, or speed loop.
012 (0Ch)	Average load B	Average load output by the servo drive (moving average for every 20 ms). The unit is percentage (%).
013 (0Dh)	Peak load B	The maximum load output by the servo drive. The unit is percentage (%).
014 (0Eh)	DC Bus voltage B	Capacitor voltage after rectification. The unit is Volt.
015 (0Fh)	Load Inertia ratio B D1 Dec	Ratio of load inertia and motor inertia. The unit is 0.1 times.
016 (10h)	IGBT temperature B	IGBT temperature. The unit is °C.
017 (11h)	Resonance frequency B Dec	Resonance frequency of the system, including 2 groups of frequency, F1 and F2. When monitoring via panel, pressing SHF can switch the display of both: F2 shows no decimal point while F1 shows one. When reading through communication (mapping parameter): Low-16 Bit (Low WORD) returns frequency F2. High-16 Bit (High WORD) returns frequency F1.
018 (12h)	Z phase offset B Dec	The offset between the motor position and Z phase. The range is from -5000 to +5000. Where it overlaps with Z phase, its value is 0. The bigger the value is, the more the offset will be.
019 (13h)	Mapping parameter #1 B	Return the value of parameter P0-25 which is mapped by P0-35.
020 (14h)	Mapping parameter #2 B	Return the value of parameter P0-26 which is mapped by P0-36.
021 (15h)	Mapping parameter #3 B	Return the value of parameter P0-27 which is mapped by P0-37.
022 (16h)	Mapping parameter #4 B	Return the value of parameter P0-28 which is mapped by P0-38.
023 (17h)	Mapping monitoring variable # 1 B	Return the value of parameter P0-09 which is the monitoring variables mapped by P0-17.
024 (18h)	Mapping monitoring variable # 2 B	Return the value of parameter P0-20 which is the monitoring variables mapped by P0-18.
025 (19h)	Mapping monitoring variable # 3 B	Return the value of parameter P0-11 which is the monitoring variables mapped by P0-19.

Code	Name of Variables / Attribute	Descriptions
026 (1Ah)	Mapping monitoring variable # 4 B	Return the value of parameter P0-12 which is the monitoring variables mapped by P0-20.
028 (1Ch)	Alarm codes	Alarm codes of DMCNET mode (applicable to A2-F, A2-N, and A2-M/U/L)
029 (1Dh)	Feedback of auxiliary encoder (PUU)	The position feedback from auxiliary encoder (CN5) (applicable to A2-F)
030 (1Eh)	Position error of auxiliary encoder (PUU)	Position deviation between position feedback (from CN5) and command (applicable to A2-F)
031 (1Fh)	Position error or main/auxiliary encoder (PUU)	Feedback position deviation between main encoder and auxiliary encoder (applicable to A2-F)
035 (23h)	Indexing coordinate command	The current command of the indexing coordinates. The unit is PUU (user unit).
037 (25h)	Compare data of COMPARE	Display the compare data. This actual compare data is a compare value plus an offset value via P1-23 and P1-24. CMP_DATA = DATA_ARRAY[*] + P1-23 + P1-24
038 (26h)	Voltage level of battery	The voltage level of battery for an absolute encoder.
039 (27h)	DI status (Integrated) Hex	The integrated DI status of the servo drive. Each bit corresponds to one DI channel. The source includes hardware channel / software P4-07 which is determined by P3-06.
040 (28h)	DO status (Hardware) Hex	The real status of Digital Output hardware. Each bit corresponds to one DI channel.
041 (29h)	Drive Status	Return the value of P0-46. Please refer to the description of the parameter.
043 (2Bh)	CAP, data capturing	The Data captured by CAP hardware from the latest time Note: CAP could continuously capture many points.
048 (30h)	Auxiliary encoder CNT	The value of pulse counter from auxiliary encoder (CN5)
049 (31h)	Pulse command CNT	The value of pulse counter from pulse command (CN1)
050 (32h)	Speed command (integrated) D1 Dec	The processed speed command. The unit is 0.1 r/min. The source might be analog, register, or position loop.
051 (33h)	Speed feedback (immediate) D1 Dec	Current actual speed of the motor. The unit is 0.1 r/min.
052 (34h)	Speed feedback (filter) D1 Dec	Current actual speed of the motor. The unit is 0.1 r/min. (The low-pass filter has been applied to this value)

Code	Name of Variables / Attribute	Descriptions
053 (35h)	Torque command (integrated) D1 Dec	The integrated torque command. The unit is 0.1 percent (%). The source might be analog, register, or speed loop.
054 (36h)	Torque feedback D1 Dec	Current actual torque (force) of the motor. The unit is 0.1 percent (%).
055 (37h)	Electric current feedback D2 Dec	Current actual current of the motor. The unit is 0.01 ampere (Amp).
056 (38h)	DC Bus voltage D1 Dec	Capacitor voltage after rectification. The unit is 0.1 volt.
059 (3Bh)	Pulse from E-Cam master axis (accumulation)	The accumulative pulse number of E-Cam master axis. It is the same as P5-86. A2-L does not support this function.
060 (3Ch)	Pulse from E-Cam master axis (increment)	The incremental pulse number from master axis. The unit is pulse number per msec. A2-L does not support this function.
061 (3Dh)	Pulse from E-Cam mast axis (lead pulse)	The lead pulse of E-Cam master axis which is used to judge the engaging condition. When it is disengaged: lead pulse = P5-87 or P5-92. When the value is 0, it will be engaged. When it is engaged: lead pulse = P5-89. When the value is 0, it will be disengaged. A2-L does not support this function.
062 (3Eh)	The position of E-Cam axis	The position of E-Cam master axis. The input of E-Cam table (master axis). Unit: The pulse is from the master axis. When the incremental pulse from master axis is P, the axis rotates M cycle (P5-83 = M, P5-84 = P). A2-L does not support this function.
063 (3Fh)	Position of E-Cam slave axis	The position of E-Cam slave axis. The input of E-Cam table (slave axis). Unit: PUU A2-L does not support this function.
064 (40h)	Terminal register of PR command	In PR mode, the termination of position command (Cmd_E)
065 (41h)	Output register of PR command	In PR mode, the accumulative output of position command
067 (43h)	PR target speed	The target speed of path command in PR mode. The unit is PPS (Pulse Per Second).
068 (44h)	S-curve filter (input)	The input commands of S-curve filter which is used to smooth the input command. It is effective in PR mode, E-Cam, and speed command. A2-L does not support this function.

Code	Name of Variables / Attribute	Descriptions
069 (45h)	S-curve filter (output)	The output commands of S-curve filter which is used to smooth the output command. It is effective in PR mode, E-Cam and speed command. A2-L does not support this function.
072 (48h)	Speed command (analog) B D1 Dec	The speed command is issued from analog channel. The unit is 0.1 r/min. This function is supported by A2-M/U/L.
076 (4Ch)	Speed command of PR contour	In PR mode, the programmed trapezoid speed curve is determined by the target speed, acceleration time, deceleration time, and moving distance (before S-curve filter). The unit is PPS (Pulse Per Second).
081 (51h)	Synchronous capture axis Incremental input pulse	When synchronous capture axis is enabled, the received pulse number between two captures can be used to measure the real distance of Mark.
082 (52h)	PR number that is currently executed	To inform HMC the PR number that is being executed. (It is applicable to A2-F.)
084 (54h)	Synchronous capture axis Deviation pulse number	The deviation between the real output pulse and the target pulse when synchronous capture axis is enabled. If it reaches the synchronization, the value will be close to 0.
091 (5Bh)	The feedback of indexing coordinate	The immediate feedback position of indexing coordinates. The unit is PUU (user unit).
096 (60h)	Firmware version Dec	It includes two versions, DSP and CPLD. When monitoring via the panel, pressing the SHF Key can switch the display of both: DSP shows no decimal point while CPLD shows one. When reading through communication (parameter mapping): Low-16 Bit (Low WORD) returns DSP version number. High-16 Bit (High WORD) returns CPLD version number.
098 (62h)	PLC scan time	The update time of DI/DO. The unit is 0.5 msec.
109 (6Dh)	The amount of data array	Returns the amount of data array. The unit is DWORD (32 Bits)
111 (6Fh)	Error code of the servo drive	Error code of the servo drive: only for the control loop, not including the motion controller.
112 (70h)	CANopen SYNC TS (hasn't been through the filter)	The time the servo drive receives SYNC signal (TimeStamp).The unit is usec.
113 (71h)	CANopen SYNC TS (has been through the filter)	The time the servo drive receives SYNC signal and has been through the filter. The unit is usec.
114 (72h)	CANopen timing synchronization	To synchronize the device timing with the controller during the operation. The unit is usec.

Code	Name of Variables / Attribute	Descriptions
116 (74h)	The differential between position and Z phase of auxiliary encoder (pulse)	The differential between the current position and Z phase position of auxiliary encoder (applicable to A2-F)
120 (78h)	DMCNET connection status	DMCNET connection status (applicable to A2-F and A2-N)
	EtherCAT communication error rate	EtherCAT communication error rate (applicable to A2-E)
121 (79h)	The PDO packet of DMCNET is lost during transmission (communication error rate)	Accumulative number of the lost DMCNET PDO packet (applicable to A2-F and A2-N) Format: chAchB chB chA For example, 459010 = 0x070102 chAchB _{error} = 7, chB _{error} = 1, chA _{error} = 2
123 (7Bh)	The returned value when monitoring via panel	The returned value when monitoring via the panel

7.2.2 Description of Data Array

Many functions of motion control, such as CAPTURE, COMPARE, and E-Cam (A2-L does not support E-Cam function), are the data that needs to be saved in large amount of memory space. Therefore, the servo drive reserves a continuous internal space to satisfy the need. The main feature of the data array is as the followings:

Feature Introduction of Data Array	
Usage	<ul style="list-style-type: none"> ● Save the captured data of CAPTURE ● Save the compared value of COMPARE ● Save the contour table of E-Cam <p>Note:</p> <ol style="list-style-type: none"> 1. The system does not partition off the data array into the individual space of CAP, CMP, and E-Cam. The user could program it according to the demand. Therefore, the space might be overlapped. Please pay close attention to it when using. 2. A2-L does not support E-Cam function.
Size of Data Array	<ul style="list-style-type: none"> ● 32-bit integer x 800 (refer to P5-10) ● Each data has its corresponding address. Specify the address is a must when reading or writing the data. ● The 800 data is from 0 to 799.
Data Retained	<ul style="list-style-type: none"> ● Manually set up the saving (P2-08 = 30, 35) is a must and the data should be saved in EEPROM of the servo drive. ● Save the data when it is Servo Off. ● The data will be loaded into data array automatically when it is Servo On.
Accessing Window	<ul style="list-style-type: none"> ● Should be accessed via parameters P5-10 ~ P5-13.

The content of the data array cannot be read or written directly. You need to read or write the data via parameters P5-10 ~ P5-13. The description of the parameters is as the followings:

Description of Related Parameter about Data Array		
Parameter	Name	Description
P5-10	Size of data array	Return the size of data array (read-only).
P5-11	Reading / writing address	Set the desired address of reading and writing.
P5-12	Reading / writing window #1	<p>Read via panel: After reading the content of P5-11, the value of P5-11 will not change.</p> <p>Write via panel: After writing the content of P5-11, the value of P5-11 will increase 1 automatically.</p> <p>-----</p> <p>Read via communication: After reading the content of P5-11, the value of P5-11 will increase 1 automatically.</p> <p>Write via communication: After writing the content of P5-11, the value of P5-11 will increase 1 automatically.</p>

Description of Related Parameter about Data Array		
Parameter	Name	Description
P5-13	Reading / writing window #2	<p>Read via panel: After reading the content of P5-11, the value of P5-11 will increase 1 automatically.</p> <p>Write via panel: It cannot be written via panel.</p> <p>-----</p> <p>Read via communication: After reading the content of P5-11, the value of P5-11 will increase 1 automatically.</p> <p>Write via communication: After writing the content of P5-11, the value of P5-11 will increase 1 automatically.</p>

Set the desired reading / writing address via P5-11 first. Then, read / write P5-12 or P5-13 in order to access the content of data array. If users desire to continuously write 3 data, 100, 200, and 300 into the address of data array, 11, 12, and 13, the operation steps are as follows:

A. Write via panel: Use P5-12 (reading / writing window #1), since P5-13 does not support writing via panel:

1. Set address: Set P5-11 to 11 (The first written address)
2. Write into data: Set P5-12 to 100 (After writing 100 into address 11 in data array, the value of P5-11 will increase 1 automatically.)
 - Set P5-12 to 200 (After writing 200 into address 12 in data array, the value of P5-11 will increase 1 automatically.)
 - Set P5-12 to 300 (After writing 300 into address 13 in data array, the value of P5-11 will increase 1 automatically.)

The last step is to read address 11, 12, and 13, and check if the content is the value that you just wrote into.

B. Read via panel: Use P5-13 (reading / writing window #2) so as to continuously read the content.

1. Set address: Set P5-11 to 11 (The first read address)
2. Read the data: When the panel displays P5-13,
 - Press the **SET** Key for the first time and show the content of address 11. Then, press the **MODE** Key to exit.
 - Press the **SET** Key for the second time and show the content of address 12. Then, press the **MODE** Key to exit.
 - Press the **SET** Key for the second time and show the content of address 13. Then, press the **MODE** Key to exit.

Note: Every time when reading the data via P5-13, the value of P5-11 will increase 1 automatically. Thus the user could continuously read the data.

If reading the data via P5-12, then the value of P5-11 will not change. The user is unable to read the next data automatically.

If users desire to read / write the data array via communication, the operation procedure is similar to that of the panel. Moreover, the functions of P5-12 and P5-13 are the same. If users desire to write 6 data, 100, 200, 300, 400, 500, and 600 into the address of data array via Modbus communication command 0x10 (continuous writing), the content of the issued command is as the followings:

Content of Communication Command: Write into Data Array									
No.	Command	Start Add.	Written Amount	P5-11		P5-12		P5-13	
				Low Word	High Word	Low Word	High Word	Low Word	High Word
1	0x10	P5-11	6 (Word)	11	0	100	0	200	0
				The first address		The first data		The second data	
2	0x10	P5-11	6 (Word)	13	0	300	0	400	0
				The third address		The third data		The fourth data	
3	0x10	P5-11	6 (Word)	15	0	500	0	600	0
				The fifth address		The fifth data		The sixth data	

If users desire to read the value of data array in order to check the previous written content, users can write the desired reading start address into P5-11 via MODBUS communication command 0x06 (write 1 data). The issuing communication command is as the following:

Content of Communication Command: Set the Reading Address of Data Array			
No.	Command	Start Add.	Written Data
4	0x06	P5-11	11

Then, read the content of specified address by communication command 0x03 (continuous reading). The issuing communication command is as follows:

Content of Communication Command: Read Data Array				Return Data					
No.	Command	Start Add.	Read Amount	P5-11		P5-12		P5-13	
				Low Word	High Word	Low Word	High Word	Low Word	High Word
5	0x03	P5-11	6 (Word)	11	0	100	0	200	0
				Read address		Data of address 11		Data of address 12	
6	0x03	P5-11	6 (Word)	13	0	300	0	400	0
				Read address		Data of address 13		Data of address 14	
7	0x03	P5-11	6 (Word)	15	0	500	0	600	0
				Read address		Data of address 15		Data of address 16	

The return value on the right-hand side of the above table represents the read parameters, P5-11, P5-12, and P5-13, which is also the content of address 11 ~ 16 in data array.

7.3 Description of Motion Axes

The motion axis is an internal counter of the servo drive. It is used for counting the absolute position of the axis (32-bit integer). The following motion axes are included in this servo drive:

Name of the Axis	Description	Access	Attribute
1. Main Encoder (P5-16)	It represents the absolute feedback position of the motor. The unit is PUU (user unit).	R	Physical Axis
2. Auxiliary Encoder (P5-17)	It is counted by the pulse signal from CN5 and usually connects to the second encoder or linear scale. Its pulse is A/B type.	R/W	Physical Axis
3. Pulse Command (P5-18)	It is counted by the pulse signal from CN1 and usually connects to the pulse command of the controller. The pulse type could be set by P1-00.	R/W	Physical Axis
4. Capture Axis (P5-37)	It is the axis which has CAP function. Its command source could be the above-mentioned axes 1 ~ 3, which can write the new value into it and has an offset from the physical axis. Moreover, after capturing the first point, the axis position can be redefined.	R/W	Functional Axis
5. Compare Axis (P5-57)	It is the axis which has CMP function. Its command source could be the above-mentioned axes 1 ~ 4, which can write the new value into it and has an offset from the physical axis.	R/W	Functional Axis
6. Master Axis (P5-86)	It is the master axis of E-Cam. Its command source could be the above-mentioned axes 2, 3, 4, and 7, which can write the new value into it and has an offset from the physical axis.	R/W	Functional Axis
7. Command Axis in PR Mode	The command position is from the path generator in PR mode.	R	Virtual Axis
8. Internal Time Axis	It is the internal accumulative time counter of the servo drive. The value increases 1 every 1ms.	R	Virtual Axis
9. Synchronous Capture Axis (P5-77)	It is similar to Capture Axis (P5-37); however, it automatically adjusts the incremental pulse between two CAPs to the setting value of P5-78. (This function is available in the firmware version V1.009 or above versions)	R/W	Virtual Axis

Note: Physical Axis: The position value is counted from the actual hardware signal.

Functional Axis: It is the virtual axis which has been processed by the physical. The value might not be the same as the source of physical axis. However, the incremental value is the same as the one in physical axis.

Virtual Axis: The axis position comes from the internal firmware of the servo drive. The command axis of PR mode is not instantaneous; therefore, it cannot be the command source axis of CAP and CMP function. However, it could be the command source of master axis of E-Cam.

7.4 Description of PR Mode

PR Procedure: It is the smallest unit of command. Command could be one or many procedures to constitute.

Procedure is triggered by DI.CTRG. POS0 ~ POS5 are used to specify the triggered procedure number.

The triggered procedure is completed and will trigger the next one automatically. The procedure number can be set and the delay time between procedures as well.

The E-Cam function is provided in PR mode. It can be enabled via PR procedure. After it is disabled, it can return to the specified PR procedure.

7.5 The Difference between General PR Mode and the One in ASDA-A2

	General PR Mode	PR Mode in A2
Command Number	8	64
Command Type	Positioning Command	Positioning / Constant speed Command PR jump, write in parameters
Position Command Parameter	<ul style="list-style-type: none"> ● Absolute or incremental ● Acceleration / Deceleration time x 1 set ● Motion speed x 8 sets ● Delay time x 8 sets 	<ul style="list-style-type: none"> ● Absolute / incremental can be set individually ● Acceleration / Deceleration time x 16 sets ● Motion speed x 16 sets ● Delay time x 16 sets
Command Triggering Time	It has to wait until DO.ZSPD is ON.	Anytime will do. It could specify the next command issuing method (in sequence / interrupt / overlap)
Command Triggering Method	<ul style="list-style-type: none"> ● Use DI.CTRG + POSn 	<ul style="list-style-type: none"> ● Use DI.CTRG + POSn ● Event trigger: DI.Event + CAP complete ● P5-07, fill in PR number to trigger.
Position Command PROFILE	<ul style="list-style-type: none"> ● Trapezoid curve with S-curve filter (If S-curve is not enabled, then it has no function of acceleration / deceleration) 	<ul style="list-style-type: none"> ● Trapezoid curve with S-curve filter (Trapezoid curve and S-curve can be set individually.)
Format of Position Command	<ul style="list-style-type: none"> ● Two registers for turns and pulse within one turn respectively. 	<ul style="list-style-type: none"> ● PUU (32-bit)
Homing Function	<ul style="list-style-type: none"> ● The function is enabled automatically when the power is On. (Servo ON for the first time) ● Use DI.SHOM to trigger. 	<ul style="list-style-type: none"> ● The function is enabled automatically when the power is On. (Servo ON for the first time) ● Use DI.SHOM to trigger ● PR 0 = Homing ● After homing is completed, the specified PR will be executed automatically.

	General PR Mode	PR Mode in A2
Software limit protection	No	Yes

7.6 The Position Unit of PR Mode

The position data of PR mode is represented by PUU (Pulse of User Unit). It is also the proportion between the controller position unit and the internal position unit of the servo drive, which is the so-called electronic gear ratio of the servo drive.

1. The position unit of the servo drive (pulse): Encoder unit: 1280000 (pulse/rev), which will not change.
2. User unit (PUU): The unit of the controller.

P pulse per revolution (PUU/rev), the gear ratio should set as:

$$\text{GEAR_NUM (P1-44) / GEAR_DEN (P1-45) = 1280000 / P}$$

7.7 Description of Register in PR Mode

1. Position register of PR mode: All is represented in PUU (Pulse of User Unit).
2. Command register (monitoring variable 064): Command termination register Cmd_E. It represents the absolute terminal coordinate of position command.
3. Command output register (monitoring variable 001): Cmd_O; it represents the absolute coordinate from the current output command.
4. Feedback register (monitoring variable 000): Fb_PUU; it shows the absolute coordinate from the feedback position of the motor.
5. Deviation register (monitoring variable 002): Err_PUU; it is the deviation between the register from command output and feedback register.
6. In PR mode, either in operation or stop status, it satisfies the condition of $\text{Err_PUU} = \text{Cmd_O} - \text{Fb_PUU}$.

Influence brought by position command:

Type of Command	When issuing the command =>	=> When command is executing =>	=> Command is completed
Absolute Positioning Command	Cmd_E = command data (absolute) Cmd_O does not change. DO.CMD_OK is OFF	Cmd_E does not change. Cmd_O continuously output ...	Cmd_E does not change. Cmd_O = Cmd_E DO.CMD_OK is ON

Type of Command	When issuing the command = >	= > When command is executing = >	= > Command is completed
Incremental Positioning Command	Cmd_E+= command data (incremental) Cmd_O does not change. DO.CMD_OK is OFF	Cmd_E does not change. Cmd_O continuously output ...	Cmd_E does not change. Cmd_O = Cmd_E DO.CMD_OK is ON
Issue the command of DI : STP to stop the command anytime	Cmd_E does not change. Cmd_O continuously output DO.CMD_OK is unchangeable	Cmd_E does not change. Cmd_O stops according to the deceleration curve	Cmd_E does not change. Cmd_O = position after stop DO.CMD_OK is ON
Homing Command	Cmd_E does not change. Cmd_O does not change. DO.CMD_OK is OFF DO.HOME is OFF	Cmd_E continuously output Cmd_O continuously output	Cmd_E = the absolute position of Z Cmd_O = position after stop DO.CMD_OK is ON DO.HOME is ON
Speed Command	Cmd_E continuously output. Cmd_O continuously output. When the speed command is completed, it means the speed reaches the setting value and does not stop. DO.CMD_OK is OFF		
Enter PR (Servo Off->On or switch the mode and enter into PR mode)		Cmd_O = Cmd_E = current feedback position	
Note: The incremental positioning command is accumulated by command termination Cmd_E. It is neither related to the current position of the motor nor the command time.			

7.8 Homing Description of PR Mode

The purpose of homing is to connect the Z pulse position of motor encoder to the internal coordinate of the servo drive. The coordinate value corresponded by Z pulse can be specified.

After homing is completed, the stopped position will not be the Z pulse. It is because it has to decelerate to stop when finding the Z pulse. It might therefore exceed a bit. However, since the position of Z pulse has correctly setup, it would not influence the accuracy of positioning. For example, when specifying the coordinate value corresponded by Z pulse is 100 and it is $\text{Cmd_O} = 300$ after homing, it means the deceleration distance is $300 - 100 = 200$ (PUU). Since $\text{Cmd_E} = 100$ (Z's absolute coordinate), if desiring to return to Z pulse position, issue the positioning command, absolute 100 command or incremental 0 command.

After homing is completed, it will execute the specified PR automatically, which can move a distance of offset after homing.

When it is executing homing, software limit is disabled.

7.9 DI / DO Provided by PR Mode and Diagrams

DI signal:

CTRG, SHOM, STP, POS 0 ~ 5, ORG, PL (CCWL), NL (CWL), EV1 ~ 4

DO signal:

Cmd_OK, MC_OK, TPOS, ALM, CAP_OK, CAM_AREA

System frame:

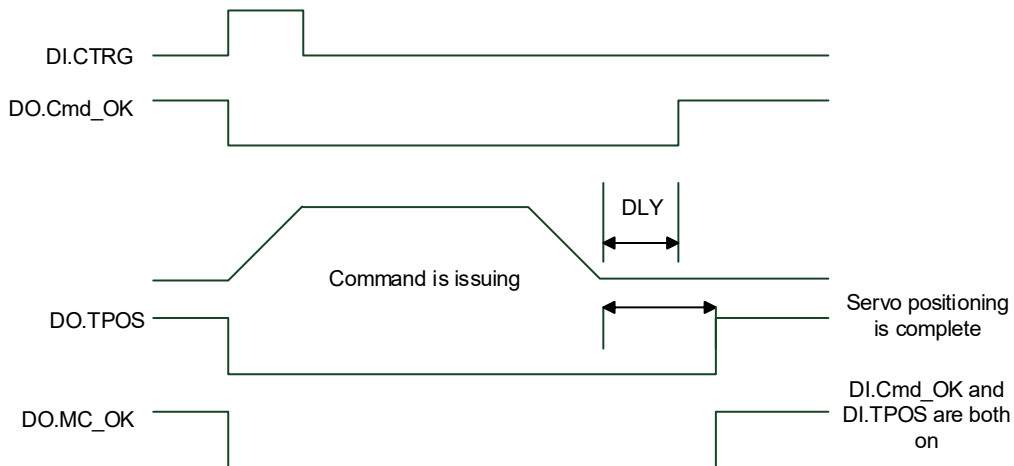

Description of command triggered method in PR mode:

64 command procedures are in each axis of PR mode. Procedure #0 is homing and the others (#1 ~ #63) are the procedures that users can self-define. The command triggered method is concluded as the followings:

	Command Source	Description
Standard trigger	DI.CTRG + POS0 ~ 5	Use DI.POS0 ~ 5 to trigger the desired procedure number. Then, use the rising edge of DI.CTRG to trigger PR command. Application: PC or PLC that issues command via DI
Functional trigger	DI.STP, SHOM	When DI.STP is from OFF → ON, the command stops in half way. When DI.SHOM is from OFF → ON, it starts homing.
Event trigger	DI.EV1 ~ 4	The status changing of DI.EV1 ~ 4 can be the triggering event. Set the triggered procedure number from OFF → ON by parameter P5-98. Set the triggered procedure number from ON → OFF by parameter P5-99. Application: connect to the sensor and trigger the preset procedure.
Software trigger	P5-07	Directly write the procedure number into P5-07 and trigger command. Both panel and communication (RS-232/485 / CANopen) can do. Application: PC or PLC that issues command via communication.
Other	CAP trigger E-CAM disengage trigger	After the capture is completed, procedure #50 can be triggered and activated by the setting value Bit 3 of P5-39.X. When E-cam is disengaged and returns to PR mode, the procedure specified by P5-88 BA setting value can be triggered. A2-L does not support E-Cam function.

7.10 Parameter Settings

- 1) Target speed: P5-60 ~ P5-75, 16 PR in total

Bit	15 ~ 0
W0	TARGET_SPEED: 0.1 ~ 6000.0 (r/min)

- 2) Accel / Decel time: P5-20 ~ P5-35, 16 PR in total

Bit	15 ~ 0
W0	T_ACC / T_DEC: 1 ~ 65500 (msec)

Note: The deceleration time used by DI: STP/EMS/NL(CWL)PL(CCWL) is defined via P5-07.

- 3) Pause time: P5-40 ~ P5-55, 16 PR in total

Bit	15 ~ 0
W0	IDLE : 0 ~ 32767 (msec)

- 4) PR parameters: P5-00 ~ P5-09, P6-00 ~ P6-01, 12 DWORD in total

	32-bit
P5-00	Reserved
P5-01	Reserved (for test only; do not use it)
P5-02	Reserved (for test only; do not use it)
P5-03	Deceleration time of auto protection
P5-04	Homing mode
P5-05	1 st Speed setting of high speed homing
P5-06	2 nd Speed setting of low speed homing
P5-07	PR command register
P5-08	Forward software limit
P5-09	Reverse software limit
P6-00	Homing setting
P6-01	Origin definition (Z pulse position)

Note: Path (procedure)

- 5) PR Definition: P6-02 ~ P7-27, (64-bit), 63 sets of PR in total (2N)

Bit	31 ~ 28	27 ~ 24	23 ~ 20	19 ~ 16	15 ~ 12	11 ~ 8	7 ~ 4	3 ~ 0
DW0	TYPE
DW1	DATA (32-bit)							

Each PR has two parameters; the PR function is determined by TYPE. DATA represents position or speed data while the others are the additional information.

6) SPEED, Constant speed control: TYPE = 1

Bit	31 ~ 28	27 ~ 24	23 ~ 20	19 ~ 16	15 ~ 12	11 ~ 8	7 ~ 4	3 ~ 0
DW0	-	-	DLY	-	DEC	ACC	OPT	1
DW1	DATA (32 bit): Target speed. Unit: Defined by OPT.UNIT							

When this command is executing, the motor accelerates or decelerates from the current speed until it reaches the target speed. After the command is completed, the motor will remain at the same speed and never stop.

OPT:

OPT			
Bit 7	Bit 6	Bit 5	Bit 4
-	UNIT	AUTO	INS

※DI.STP stop and software limit are acceptable.

INS: When this PR is executing, it will interrupt the previous PR.

AUTO: When the speed reaches the constant speed area, the next PR will be loaded automatically.

UNIT: 0 means the unit is 0.1 r/min; 1 means the unit is PPS (Pulse Per Second)

ACC / DEC: 0 ~ F, Accel / Decel number

ACC (4-bit) / DEC (4-bit)	Index P5-20 ~ P5-35
----------------------------------	---------------------

SPD: 0 ~ F, target speed number

SPD (4-bit)	Index P5-60 ~ P5-75
--------------------	---------------------

DLY: 0 ~ F, delay time number. The delay after executing this PR. The external INS is invalid.

DLY (4-bit)	Index P5-40 ~ P5-55
--------------------	---------------------

7) POSITION, Positioning control: (TYPE = 2, PR is completed and stopped), (TYPE = 3, the next PR is executed automatically after the PR is completed)

Bit	31 ~ 28	27 ~ 24	23 ~ 20	19 ~ 16	15 ~ 12	11 ~ 8	7 ~ 4	3 ~ 0
DW0	-	-	DLY	SPD	DEC	ACC	OPT	2 or 3
DW1	DATA (32 bit): Target position, Unit: Pulse of User Unit							

OPT:

OPT				Explanation
Bit 7	Bit 6	Bit 5	Bit 4	
CMD		OVLP	INS	
0	0	-	-	Absolute position command: Cmd_E = DATA (Note 1)
1	0			Incremental position command: Cmd_E = Cmd_E + DATA (Note 2)
0	1			Relative position command: Cmd_E = Current feedback position + DATA (Note 3)
1	1			Capture position command: Cmd_E = Capture position + DATA (Note 4)

※DI.STP stop and software limit are acceptable.

INS: When this PR is executing, it will interrupt the previous PR

OVLP: It is allowed to overlap the next PR. When overlapping, please set DLY to 0.

CMD: The calculation of the position terminal command (Cmd_E) is as the followings:

Note 1: Position terminal command is determined by DATA.

Note 2: Position terminal command is determined by the previous terminal command (Monitoring variable 40h) plus DATA.

Note 3: Position terminal command is determined by the current feedback position (Monitoring variable 00h) plus DATA.

Note 4: Position terminal command is determined by the position latched by CAP (Monitoring variable 2Bh) plus DATA.

8) Special code: TYPE = 7, jump to the specified PR.

Bit	31 ~ 28	27 ~ 24	23 ~ 20	19 ~ 16	15 ~ 12	11 ~ 8	7 ~ 4	3 ~ 0
DW0	-	-	DLY	-	FUNC_CODE	-	OPT	7
DW1	PR Number (0 ~ 63)							

OPT:

OPT			
Bit 7	Bit 6	Bit 5	Bit 4
-	-	-	INS

PATH_NO: The jump target procedure number

FUNC_CODE: Reserved

DLY: The delay time after jump

9) Special code: TYPE = 8, write the specified parameter.

Bit	31 ~ 28	27 ~ 24	23 ~ 20	19 ~ 16	15 ~ 12	11 ~ 8	7 ~ 4	3 ~ 0
DW0	0	S_D	DLY	DESTINATION		OPT	8	
DW1	SOURCE							

DLY: Delay time after writing the parameters

Bit28 ~ Bit31 are not 0x0, then AL213 occurs.

S_D: Specified data source and written target.

S_D					
Bit 27	Bit 26	Bit 25	Bit 24	Explanation	
SOUR		Rsvd	DEST	Data Source	Write Destination
0	0	0	0	Constant	Parameter Px-xx
0	1		0	Parameter Px-xx	Parameter Px-xx
1	0		0	Data Array	Parameter Px-xx
1	1		0	Monitoring variable	Parameter Px-xx
0	0		1	Constant	Data Array
0	1		1	Parameter Px-xx	Data Array
1	0		1	Data Array	Data Array
1	1		1	Monitoring variable	Data Array

Rsvd is not 0, then AL213 occurs.

OPT:

OPT			
Bit 7	Bit 6	Bit 5	Bit 4
-	ROM	AUTO	INS

Para_Data: the written data

INS: When executing this PR, it interrupts the previous one.

AUTO: When this PR is completed, it will execute the next PR automatically.

ROM: 1 means to write into EEPROM at the same time. (The supported written target is parameter, if the target is data array, then it will not be written into EEPROM.)

DESTINATION: Setting of the written target

	DESTINATION		
	Bit 19 ~ 16	Bit 15 ~ 12	Bit 11 ~ 8
When DEST = 0, it represents parameter, Px-xx	P_Grp	P_Idx	
When DEST = 1, it represents data array.	Array_Addr		

P_Grp, P_Idx: Specified parameter group and number

Array_Addr: Position of the specified data array.

SOURCE: Settings of data source

Bit	SOURCE							
	31 ~ 28	27 ~ 24	23 ~ 20	19 ~ 16	15 ~ 12	11 ~ 8	7 ~ 4	3 ~ 0
SOUR = 00 means constant	Para_Data							
SOUR = 01 means parameter Px-xx	Rsvd (0x0000 0)					P_Grp	P_Idx	
SOUR = 10 means data array	Rsvd (0x0000 0)					Array_Addr		
SOUR = 11 means monitoring variable	Rsvd (0x0000 00)						Sys_Var	

P_Grp, P_Idx: specified parameter group and number

Array_Addr: specified the position of data array

Para_Data: the written constant

Sys_Var: monitor parameter code. Refer to P0-02 for its setting.

When Rsvd is not 0, it will display AL213. When P_Grp exceeds the range, it will display AL207.

When displaying AL209, it means P_Idx exceeds the range.

When Array_Addr exceeds the range, it will display AL213. And AL231 is for Sys_Var exceeding the range.

Note: 1. Firmware version 1.013 (or previous versions): Even when the written parameter is retained, the new value will not be written into EEPROM. Too frequent written will not shorten the lifetime of EEPROM.

2. Firmware version 1.013 (or later versions):

Writing parameters via PR (TYPE = 8) does not write new value into EEPROM, so it does not shorten the lifetime of EEPROM.

Note: The aim of writing parameters via PR procedure is for turning ON/OFF or adjusting some functions. (E.g. according to different positioning command to adjust P2-00, Position Loop Gain.) This procedure will continuously repeat during the operation. If the data is all written into EEPROM, it will shorten the lifetime of EEPROM.

3. If writing parameters fails, alarm AL.213 ~ 217 will occur (Refer to Chapter 10 of the manual) and the next PR which is enabled by AUTO function will not be executed.

10) Special Function: TYPE = 0xA, Indexing command.

Bit	31 ~ 28	27 ~ 24	23 ~ 20	19 ~ 16	15 ~ 12	11 ~ 8	7 ~ 4	3 ~ 0
DW0	-	OPT2	DLY	SPD	DEC	ACC	OPT	0xA
DW1	DATA (32-bit): Indexing Coordinate Command, Unit: PUU							

OPT:

OPT			
Bit 7	Bit 6	Bit 5	Bit 4
<p style="text-align: center;">DIR</p> <p>00: Always move forward (Forward Rotation) 01: Always move reverse (Reverse Rotation) 10: Shortest distance (Judging by the current position and target position) 11: Reserved</p>		OVLP	INS

INS: When this PR is executing, it interrupts the previous one.

OVLP: It is allowed to overlap the next PR. When overlapping, please set DLY to 0.

OPT2:

OPT2			
Bit 27	Bit 26	Bit 25	Bit 24
-	AUTO	-	S_LOW

AUTO: Position reached and the next PR is loaded automatically.

S_LOW: Selection of speed unit. 0 means the unit is 0.1 r/min; while 1 means 0.01 r/min

DATA (DW1): Data format

DW1: DATA (32 bits)
PUU: 0 ~ (P2-52-1)

P2-52: Size of indexing coordinates

11) Homing Definition: P6-00 ~ P6-01, (64 bits) one set of PR.

Bit	31 ~ 28	27 ~ 24	23 ~ 20	19 ~ 16	15 ~ 12	11 ~ 8	7 ~ 6	5 ~ 0
DW0	BOOT	-	DLY	DEC2	DEC1	ACC	Reserved	PATH
DW1	ORG_DEF (32-bit)							

PATH (PR): 0 ~ 3F. (6 bits)

00 (Stop): Homing completed and stops

01 ~ 3F (Auto): Homing completed and executes the specified PR: 1 ~ 63.

Note: PATH (procedure)

ACC: Acceleration time

DEC1/DEC2: The first / second deceleration time

DLY: Delay time

BOOT: Activation mode. When the POWER is ON:

0: will not do homing

1: start homing (Servo ON for the first time)

ORG_DEF: the coordinate value of the origin definition which might not be 0

1) After finding the origin (Sensor or Z), the motor has to decelerate to stop. The stop position will slightly exceed the origin. After the positioning is completed, users can determine and setup the motor position:

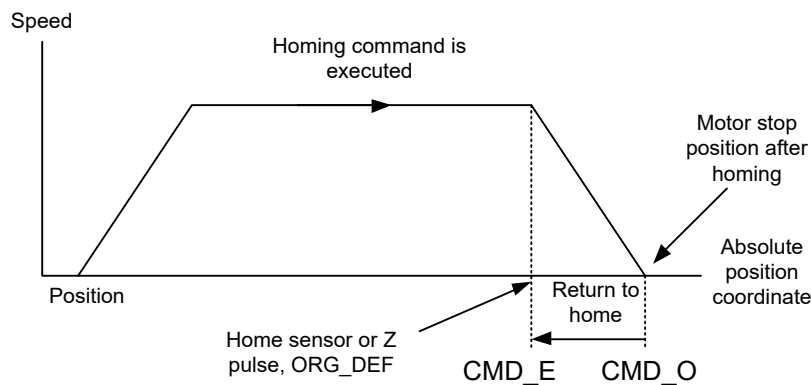

If not returning to the original point, set PATH to 0.

If desiring to return to the original point, set PATH to non-zero value and setup that PR:
absolute positioning command = ORG_DEF.

CMD_O: Command Output Position

CMD_E: Command End Position

2) Homing does not define the offset value but uses PATH to specify a path as the offset value.

After finding the origin, if the user desires to move a short distance of offset S (relative to the home Sensor or Z) and set the coordinate to P after moving: set PATH to non-zero value, set

ORG_DEF= P – S, and setup that PR: absolute positioning command = P (incremental positioning command = S will do as well)

7.10.1 The Relation between the Previous Path and the Next Path

1) Interrupt (the previous path) and overlap (the next path) can be set in every path

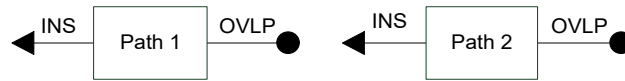

Note: Path (procedure)

2) The priority of interrupt command is higher than overlap

PATH 1	PATH 2	Relation	Output	Note
OVLP = 0	INS = 0	In sequence	DLY 1	PATH 1/2 which could be the combination of speed/position
OVLP = 1	INS = 0	Overlap	NO DLY	PATH 2 is SPEED and does not support overlap
OVLP = 0	INS = 1	Interrupt	N/A	PATH 1/2 which could be the combination of speed/position
OVLP = 1				

7.10.2 Programming the Path in PR Mode

1) Sequence command

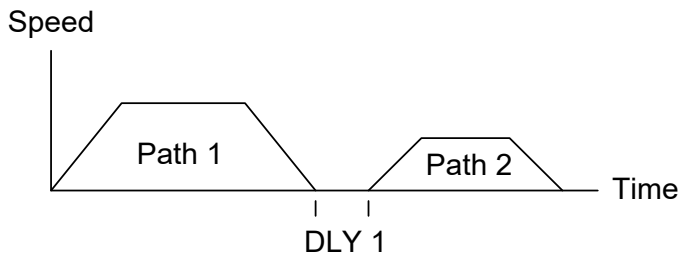

Path 1: is AUTO and has set DLY
 Path 2: does not set INS
 (DLY starts to count after completing the command)

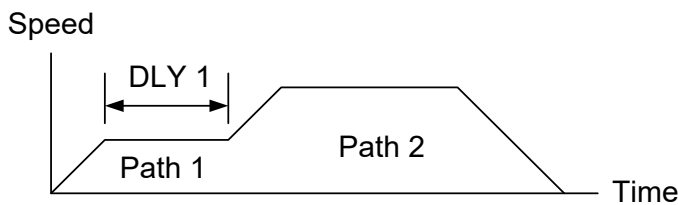

Path 1: speed command and has set DLY
 Path 2: position command
 (DLY starts to count after completing the command)

2) Overlap

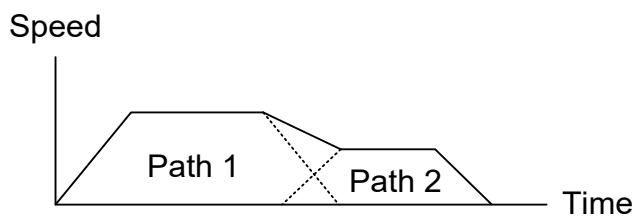

Path 1: has set OVLP but cannot set DLY
 Path 2: does not set INS

3) Internal Interrupt

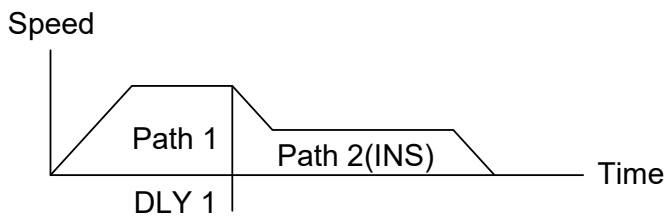

Path 1: AUTO and has set DLY
 Path 2: has set INS
 (DLY is effective to the internal interrupt)
 It can be used to pre-constitute complicated Profile

4) External Interrupt

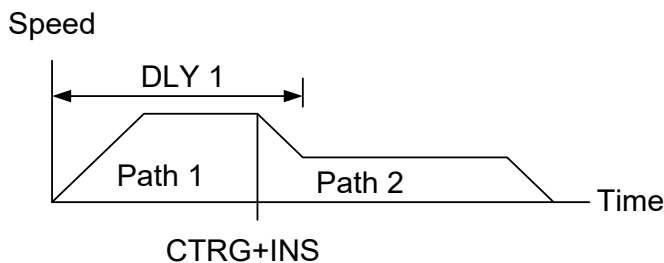

Path 1: AUTO or SINGLE regardless of the setting of DLY
 Path 2: has set INS
 (DLY is ineffective to the external interrupt)
 Profile can be changed from external any time

7.11 The Description of E-Cam Function (A2-L does not support this function)

E-Cam is a virtual cam which is implemented by software. It includes Master axis and Slave axis. The illustration is as the following:

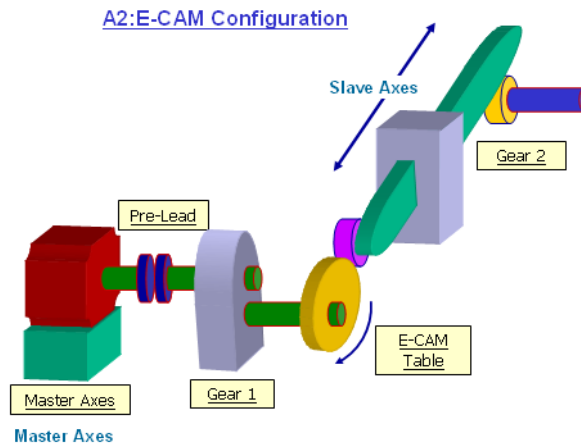

In PT mode, the position command (slave) is issued by the external pulse input (master). The relation between the two is merely linear scaling (its scaling equals to e-gear ratio). However, instead of linear scaling, E-Cam is defined by cyclic curve profile, just like the cam shape. In physical machine cam, slave axis can operate as variable speed motion, alternating motion, intermittent motion, etc. by master axis with the constant speed motion. It is very extensive in application. Using E-Cam could have similar effect. The following table describes the differences between E-Cam and Machine Cam.

	Machine Cam	E-Cam
Structure	Return to the original position after rotating a cycle.	It might not return to the original position after rotating a cycle. The structure could be in spiral shape like mosquito coil incense.
Smooth Performance	It is determined by the fineness of the real process.	It is interpolated by cubic curve via software.
Position Accuracy	Very precise (when it has no vibration)	The command is very precise, but the actual position might have deviation due to the servo delay.
Long Distance Motion	The longer the slave axis is, the bigger the cam will be. It is not easy to make.	Change the value of the table will do. It is easy to realize.
The Necessity of Master Axis	The master axis is necessary.	The master axis is unnecessary when it is applied to constant speed motion. It will do by using the internal signal of the servo drive.
Flexibility	It is inconvenient to change and modify, and it is expensive as well.	It will do by re-setting the parameter.

	Machine Cam	E-Cam
Maintenance	Machine will wear and the maintenance is necessary.	No need to maintain.
Others	The master axis needs space and it consumes energy as well.	Save the space and energy which protects the environment.

The main feature of E-Cam is as the followings:

Features of E-Cam	
Operation	Operate the E-cam in PR mode only.
Active the E-Cam Function P5-88.X	0: disable E-cam function and force to disengage (default). 1: enable E-cam function and starts to judge the engaged condition.
E-Cam Status	Stop / Pre-engage / Engage
Source of Master Axis	<ul style="list-style-type: none"> ● Physical axis: auxiliary encoder (linear scale) ● Physical axis: pulse command ● Functional axis: CAP axis (defined by CAP function) ● Virtual axis: PR command / Time axis / Synchronous capture axis
Motion Command of the Servo Drive	<p>The overlap motion command issued by PR and E-Cam Command of the Servo Drive = E-Cam command + PR command</p> <ul style="list-style-type: none"> ● The command will be issued only in Engaged status ● PR command is effective regardless of the E-Cam status. Only when E-cam is engaging and the source of master axis is PR command, PR command is 0. <p>When E-Cam is operating, its position still can be adjusted by PR command (incremental command in general).</p>
Data Storage Address of E-Cam table	<ul style="list-style-type: none"> ● It is stored in Data array and the start address is set by P5-81.
Data Size of E-Cam table	<ul style="list-style-type: none"> ● It is set by P5-82. 720 points is the maximum and 5 points is the minimum.
Data Format of E-Cam table	<ul style="list-style-type: none"> ● 32-bit signed value.
Data Content of E-Cam table	<ul style="list-style-type: none"> ● Save the position of slave axis (User unit, PUU)
The operation of E-Cam position	<ul style="list-style-type: none"> ● The master axis operates by incremental command input. ● The slave axis issues position command incrementally. ● The start and the end of E-Cam curve profile could not always be the same. It depends on the value of E-Cam table. ● The command is interpolated by cubic curve. The torque on each point will be smoothly connected because of quadratic differential operation.
DO: CAM_AREA (DO no.= 0x18)	<ul style="list-style-type: none"> ● DO: CAM_AREA: If it is on, it means the current E-Cam position is within the set position.

E-Cam provided by this servo drive and below is its functional diagram:

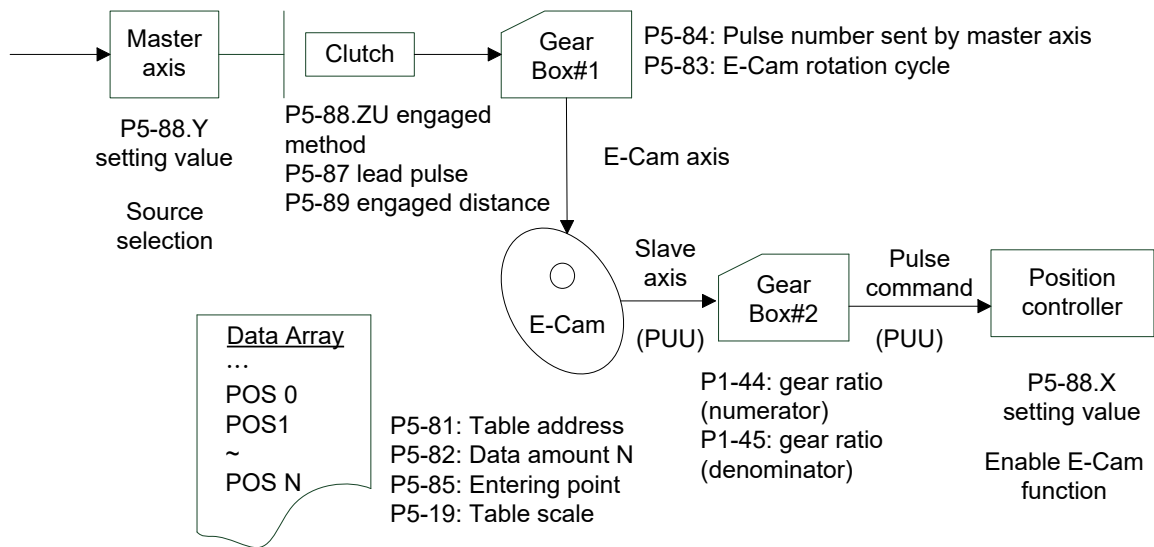

■ Master Axis, the description is as follows:

Function	The moving distance of the master axis is the source which could drive the E-Cam
Source of Master Axis The Setting Value of P5-88 Y	Source selected by P5-88.Y: <ul style="list-style-type: none"> ● Physical axis: auxiliary encoder (linear scale) ● Physical axis: pulse command ● Virtual axis: PR command / Time axis / Synchronous capture axis ● Functional axis: CAP axis (defined by CAP function)
Position of Master Axis P5-86	The position of master axis can be monitored via P5-86. It also can be written before the E-cam engaged. To change this parameter will not influence the position of the slave. It is because the moving distance of master axis remains.

■ Clutch, the description is as follows:

Function	It is used to determine the status of engaged / disengaged between the master axis and gear box # 1. The moving distance of the master axis can drive the E-Cam not until the cam is engaged.
Enable E-cam function P5-88.X	0: disable E-cam function (default value). If the cam is engaged, the cam will be forced to disengage. 1: enable E-cam function and start to judge the engaged condition
E-Cam Status	Status can be known via parameter P5-88.S: 0 – Stop; 1 – Engage; 2 – Pre-engage

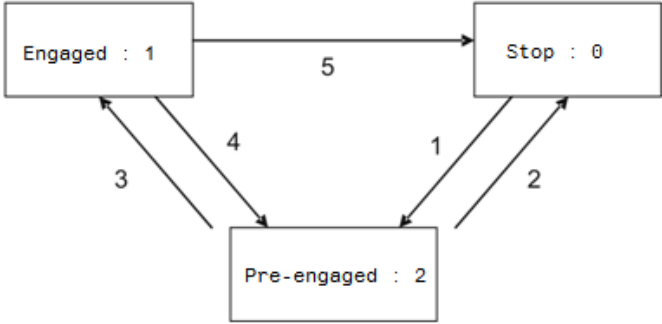
	<div style="text-align: center;">  <pre> graph TD Engaged["Engaged : 1"] -- 5 --> Stop["Stop : 0"] Engaged -- 4 --> PreEngaged["Pre-engaged : 2"] PreEngaged -- 3 --> Engaged PreEngaged -- 2 --> Stop Stop -- 1 --> PreEngaged </pre> </div> <p><u>Status Description:</u></p> <ul style="list-style-type: none"> ● Stop: It is the initial status of the cam. The E-cam will not operate with the master pulse. When E-cam function is disabled (P5-88.X=0), it returns to this status. ● Pre-engage: When the engaged condition (path 1) is established, it enters this status. The E-cam still will not operate with the master pulse. ● Engage: When it reaches pre-engaged status (path 3), it enters this status. The E-cam starts to operate with the master pulse. <p><u>Path Description:</u></p> <ul style="list-style-type: none"> ● Path 1 : When the engaged condition is established (P5-88.Z), the status is Stop → Pre-engaged. The lead pulse is determined by P5-87. ● Path 2 : When the E-cam function is disabled (P5-88.X=0), it returns to Stop status. ● Path 3 : When it is in pre-engaged status, the status is Pre-engaged → Engaged. ● Path 4 : When the disengaged condition is established (P5-88.U = 4), the status is Engaged → Pre-engaged. The lead pulse is determined by P5-92. (It is available after firmware version V1.006 sub04) ● Path 5 : When the disengaged condition is established (P5-88.U = 1, 2, 6), or the E-cam function is disabled (P5-88.X = 0), the status is Engaged → Stop.
<p>Engage Condition P5-88.Z</p>	<p>When the E-cam is in Stop status, the method of determining engaged (path 1) is as the following:</p> <p>0: Engaged immediately. If P5-88.X is set to 1, the engaged condition is established.</p> <p>1: When DI.CAM is ON, E-cam is engaged.</p> <p>2: From CAP to engaged: E-cam is engaged when CAP function is enabled. After engaged, it starts to count the moving distance. Since the CAP position is captured by hardware, it has good instantaneity and no software delay, which is suitable for the operating master axis before engaged.</p>

<p>Lead Pulse Monitoring Variables (061)</p>	<ul style="list-style-type: none"> ● In pre-engaged status, the lead pulse is the moving distance of master axis before the E-cam is engaged (path 3). It can be observed through the monitoring variable (061). Its value decreases when inputting the master pulse. When the value is 0, it enters Engaged status. ● Enter Pre-engaged status via path 1, the lead pulse is determined by the value of P5-87. ● Enter Pre-engaged status via path 4, the lead pulse is determined by the value of P5-92. ● If the setting is 0, it means no lead pulse and will enter Engaged status immediately. <p>Symbol + / - represents the direction of lead pulse. Please note that the E-cam will be unable to engage if setting the wrong direction.</p> <p>If setting the wrong direction, the value of monitoring variable (061) will increase, which is far from 0, and causes overflow at the end. If it overflows, the E-cam function will be disabled (P5-88.X=0) and the E-cam will be forced to return to Stop status.</p>																				
<p>Disengage Condition P5-88.U</p>	<p>When the E-cam is in Engaged status, the method of determining disengaged is as the following: Note: 2, 4, and 6 cannot be selected at the same time</p> <table border="1" data-bbox="475 949 1394 1877"> <thead> <tr> <th>U</th> <th>Disengage Condition</th> <th>After Disengaged</th> </tr> </thead> <tbody> <tr> <td>0</td> <td>Never disengaged.</td> <td>(Path 5) Enter Stop Status</td> </tr> <tr> <td>1</td> <td>Disengage when DI.CAM is OFF.</td> <td>(Path 5) Enter Stop Status</td> </tr> <tr> <td>2</td> <td>Master axis receives the pulse number which is set by P5-89 and stops immediately. (The symbol represents the direction)</td> <td rowspan="2">(Path 5) Enter Stop Status</td> </tr> <tr> <td>6</td> <td>(Provided by firmware version V1.009 or later versions) Same as 2, the E-cam starts to decelerate when disengaging. It is suitable for the application of calling the next PR position command right after disengaged.</td> </tr> <tr> <td>4</td> <td>(Provided by firmware version V1.009 or later versions) Master axis receives the pulse number which is set by P5-89 and stops immediately. (The symbol represents the direction)</td> <td>(Path 4) Returns to Pre-engagement Status The lead pulse is P5-92</td> </tr> <tr> <td>8</td> <td>Disable the E-cam after disengaging</td> <td>Set P5-88.X = 0</td> </tr> </tbody> </table>	U	Disengage Condition	After Disengaged	0	Never disengaged.	(Path 5) Enter Stop Status	1	Disengage when DI.CAM is OFF.	(Path 5) Enter Stop Status	2	Master axis receives the pulse number which is set by P5-89 and stops immediately. (The symbol represents the direction)	(Path 5) Enter Stop Status	6	(Provided by firmware version V1.009 or later versions) Same as 2, the E-cam starts to decelerate when disengaging. It is suitable for the application of calling the next PR position command right after disengaged.	4	(Provided by firmware version V1.009 or later versions) Master axis receives the pulse number which is set by P5-89 and stops immediately. (The symbol represents the direction)	(Path 4) Returns to Pre-engagement Status The lead pulse is P5-92	8	Disable the E-cam after disengaging	Set P5-88.X = 0
U	Disengage Condition	After Disengaged																			
0	Never disengaged.	(Path 5) Enter Stop Status																			
1	Disengage when DI.CAM is OFF.	(Path 5) Enter Stop Status																			
2	Master axis receives the pulse number which is set by P5-89 and stops immediately. (The symbol represents the direction)	(Path 5) Enter Stop Status																			
6	(Provided by firmware version V1.009 or later versions) Same as 2, the E-cam starts to decelerate when disengaging. It is suitable for the application of calling the next PR position command right after disengaged.																				
4	(Provided by firmware version V1.009 or later versions) Master axis receives the pulse number which is set by P5-89 and stops immediately. (The symbol represents the direction)	(Path 4) Returns to Pre-engagement Status The lead pulse is P5-92																			
8	Disable the E-cam after disengaging	Set P5-88.X = 0																			
<p>Auxiliary Selection P5-88.BA</p>	<p>When the E-cam disengaged, if it is in the setting distance (P5-88.U=2), it returns to Stop status and can determine the execution PR number.</p>																				

■ Gear # 1, the description is as follows:

Function	<ul style="list-style-type: none"> ● Set the relativity of master axis and E-cam axis. E.g. The master axis operates one cycle; the E-cam axis has no need to operate one cycle.
Description	<ul style="list-style-type: none"> ● E-cam axis is a virtual axis. ● The E-cam axis operates one cycle (360 degrees) means the cam operates one cycle and the slave axis operates one cycle. ● The pulse number is the unit of moving distance of the master axis. Its resolution is determined by the source.
Setting Method P5-83: M P5-84: P	<ul style="list-style-type: none"> ● If the pulse number of master axis is P, the E-cam axis operates M cycle. Then, the setting of gear ratio is P5-83 = M, P5-84 = P

■ Cam, the description is as follows:

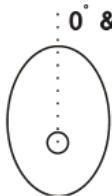
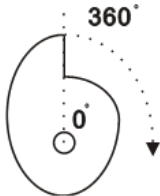
Function	<ul style="list-style-type: none"> ● Set the relation between E-cam axis and slave axis and define it in the E-cam table. E-cam axis operates one cycle and the slave axis operates one cycle.
Data Storage Address of E-Cam table	<ul style="list-style-type: none"> ● Data array. The start address is set by P5-81.
Data Format	<ul style="list-style-type: none"> ● 32-bit (It has positive and negative signs, user unit: PUU)
E-Cam Curve Scaling P5-19 0 ~ +/- 32.700	<ul style="list-style-type: none"> ● It is used to magnify (minify) the E-cam shape. ● It equals to the value of data multiplies P5-19. ● Switching the symbol, + / - , will change the operation direction of slave axis. ● If P5-19 is set to 0, the E-cam command will not be output. (The setting will be 0 for good).
Data Size	<ul style="list-style-type: none"> ● It is divided into N parts via P5-82 (> = 5) and does not exceed the limit of data array. It means 360 degrees a cycle of E-cam are divided into N areas. Each area is (360/N) degrees.
Data Content	<ul style="list-style-type: none"> ● The position data of slave axis is saved in E-cam table. (User unit: PUU). ● If E-cam is divided into N areas, the position of each area must be included in the table. It must set N + 1 points in total. It is because the position of the first point (0 degree) and the final point (360 degree) might not be the same. <div style="display: flex; justify-content: space-around; align-items: flex-start;"> <div style="text-align: center;"> <p>The data of 1.0° and 360° is identical</p>  </div> <div style="text-align: center;"> <p>The data of 2.0° and 360° is different</p>  </div> </div>

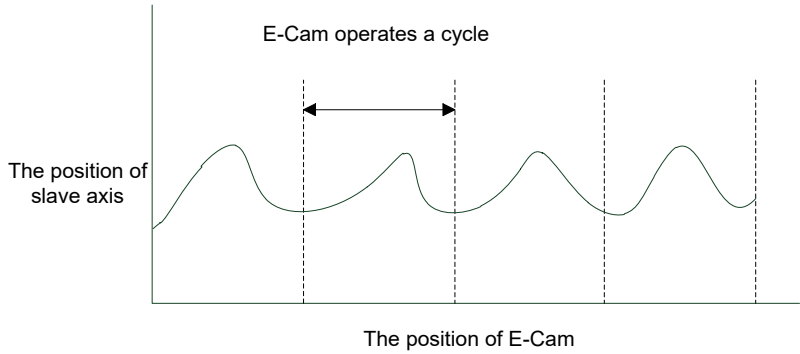
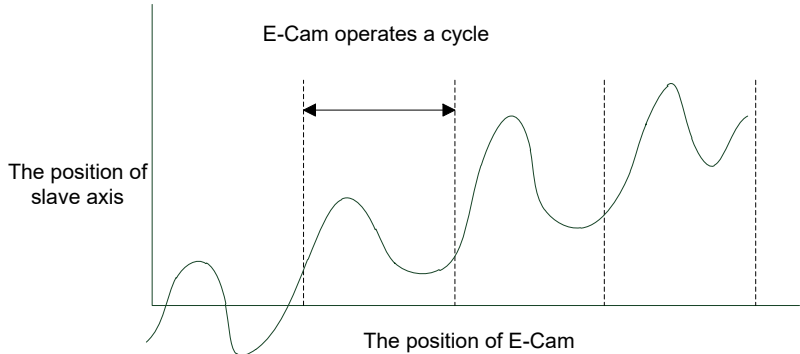
	<ul style="list-style-type: none"> ● If: <ol style="list-style-type: none"> 1. The start and final position is the same, it means after the E-cam operates a cycle, the slave axis returns to the origin position. <div style="text-align: center;">  <p>The position of slave axis</p> <p>The position of E-Cam</p> </div> 2. The start and final position is different, it means after the E-cam operates a cycle, the slave axis does not return to the origin position. <div style="text-align: center;">  <p>The position of slave axis</p> <p>The position of E-Cam</p> </div>
<p>Operation Description</p>	<ul style="list-style-type: none"> ● The slave axis is a virtual axis and the unit of slave position is PUU. ● After the E-cam is engaged, the position of the master is the entering point of P5-85. The position of the slave axis is in the corresponding point to the P5-85 in E-cam table. ● After engaging, if the master does not operate, the slave axis will not operate. If the master operates, the slave will travel according to the E-cam table. ● For one cycle of the chart, the slave axis operates a cycle. ● E-cam axis can operate in forward / reverse direction. ● If the E-cam position is between two points of the E-cam table, the position of the slave axis will be interpolated with cubic curve function. The adjacent curve remains quadratic differential at the point in order to smooth torque. The point amount of the table will not influence the smoothing operation of E-cam.

■ Gear # 2, the description is as follows:

<p>Function</p>	<ul style="list-style-type: none"> ● Set the relation between slave axis and pulse command ● The slave axis operates a cycle, but the pulse command might not operate a cycle.
<p>Description</p>	<ul style="list-style-type: none"> ● The slave axis is a virtual axis and the unit of slave position is PUU. ● The pulse command is the encoder unit (pulse). The resolution is 1280000 pulse/rev. ● For one cycle of the chart, the slave axis operates a cycle.

Setting Method P1-44:numerator P1-45:denominator	<ul style="list-style-type: none"> ● If the pulse number of slave axis is L, the motor axis operates R cycle. ● Then, the setting of gear ratio is $P1-44/P1-45 = 1280000 \times R/L$ ● The gear ratio of PT and PR is the same.
--	--

- Digital Output of E-cam, the description is as follows:

DO Name and Number	<ul style="list-style-type: none"> ● DO.CAM_AREA (DO no.= 0x18)
Function	<ul style="list-style-type: none"> ● If DO.CAM_AREA is ON, it means the position of E-cam axis is in the setting range.
When the E-cam is engaging	<ul style="list-style-type: none"> ● Set the angle range of DO ON by P5-90 and P5-91. ● Please refer to Table 1 and 2 below.
When the E-cam is disengaging	<ul style="list-style-type: none"> ● DO.CAM_AREA is OFF.

Table 1 P5-90 ≤ P5-91:

E-Cam angle	0°	~	P5-90	~	P5-91	~	360°
DO:CAM_AREA	OFF	OFF	ON	ON	ON	OFF	OFF

Table 2 P5-90 > P5-91:

E-Cam angle	0°	~	P5-91	~	P5-90	~	360°
DO:CAM_AREA	ON	ON	OFF	OFF	OFF	ON	ON

7.11.1 Function Description of CAPTURE (Data Capture)

The concept of CAPTURE is to capture the position of motion axis instantaneously by using the external trigger signal DI7, then save it in data array so as to be used for motion control afterwards. Since CAPTURE is finished by hardware, there is no software delay issue. It also can accurately capture the high-speed motion axis. The CAPTURE features provided by this servo drive is as follows.

CAPTURE Features	
Pulse Source	<ul style="list-style-type: none"> ● Main encoder of the motor ● Auxiliary encoder (linear scale) ● Pulse command <p>The selected axis will be displayed in P5-37, and the default value can be written in before capture.</p> <p>Note: When the source of COMPARE is CAP axis, the CAP source cannot be changed.</p>
Trigger signal	<ul style="list-style-type: none"> ● Triggered by DI7. The response time is 5 usec. <p>Note: DI7 directly connects to CAPTURE hardware. Thus, regardless of the setting value of P2-16 (DI Code), CAPTURE can work. When using CAPTURE, in order to avoid DI error, the system will force to disable DI function, which means the setting will be P2-16 = 0x0100 automatically. Since the value is not written into EEPROM, P2-16 will return to the default value after re-powering on.</p>

CAPTURE Features	
Trigger method	<ul style="list-style-type: none"> ● Edge trigger can select contact A/B ● It is able to continuously capture more than one point. ● It can set the trigger interval. (The interval between this trigger and the next one.)
Data storage position	<ul style="list-style-type: none"> ● Data array. The start address is set by P5-36.
Capture number	<ul style="list-style-type: none"> ● It is set via P5-38 and will not exceed the limit of data array.
Capture format	<ul style="list-style-type: none"> ● 32-bit (It has positive and negative signs.)
Auxiliary selection	<ul style="list-style-type: none"> ● After capturing the first data, the CAP axis coordinate system will be set to the value the same as P5-76. ● After capturing the first data, the COMPARE function is enabled automatically. ● After capturing all points, PR procedure # 50 is triggered automatically.
DO.CAP_OK	<ul style="list-style-type: none"> ● The default value is OFF. ● After capturing the last point, this DO is ON. ● Set P5-39.X0 to 1 so as to activate CAPTURE function and this DO is OFF.
Note	<ul style="list-style-type: none"> ● If P5-38=0, set the value of P5-39 X, Bit0 to 1 will disable the CAPTURE function. Clear the setting value of P5-39 X, Bit0 to 0 and set DO.CAP_OK to OFF. ● Since the capture axis is 32-bit wide, the accumulation will cause overflow. Please avoid this.

The CAP data is saved in data array and the first CAP data locates in P5-36. The CAP number has no limit, thus it can be set via P5-38. The last CAP data is saved in P5-36 + P5-38 - 1. Set the value of P5-39 X, Bit0 to 1 so as to activate CAP function. Every time when DI7 is triggered, one data will be captured and saved in data array. Then, the value of P5-38 will decrease one automatically until the CAP number reaches the setting value (P5-38 = 0). The CAP procedure is completed, the setting value of P5-39 X, Bit0 will be cleared to 0 and DO.CAP_OK is ON.

When capturing the first data, the position of CAP axis can be reset. The first CAP value will be the value set by P5-76. And the value of the second CAP data will be the incremental value from the first data. This method is called Relative Capture. If not selecting the first data reset, it is called Absolute Capture.

When capturing the first data, it automatically activates COMPARE function, which means the COMPARE function, is activated via DI7.

The diagram of CAP:

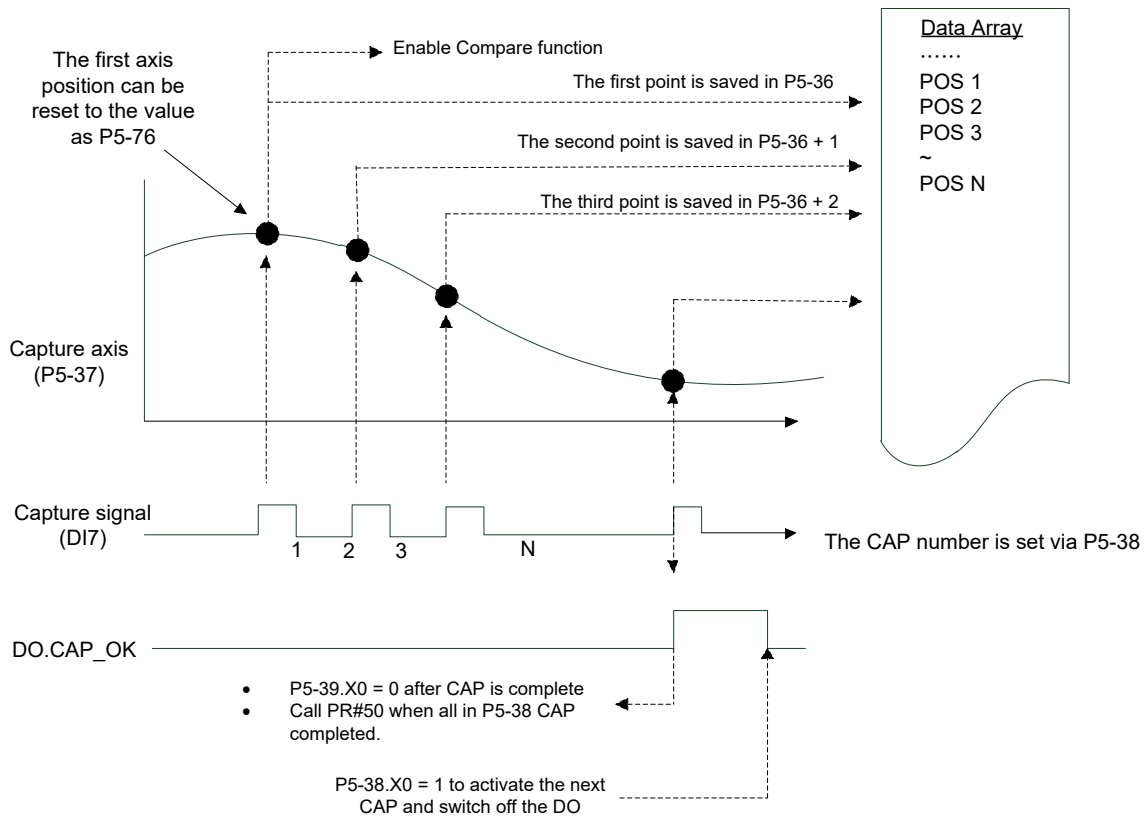

7.11.2 Function Description of COMPARE (Data Compare)

The concept of COMPARE is to compare the instant position of motion axis with the value which is saved in data array. Then output DO4 after the COMPARE condition is established for motion control. Since COMPARE is finished by hardware, there is no problem of software delay. It also can accurately compare the high-speed motion axis. The COMPARE features provided by this servo drive is as follows.

COMPARE Features	
Pulse Source	<ul style="list-style-type: none"> ● Main Encoder of the Motor ● Auxiliary Encoder (linear scale) ● Pulse Command ● CAP Axis (set by CAPTURE). When selecting this axis, CAP source cannot be changed. <p>The selected axis is displayed in P5-57. Before compare, the default value can be written in.</p>
Output Signal	<ul style="list-style-type: none"> ● Output by DO4 and the response time is 5 usec. <p>Note: DO4 directly connects to COMPARE hardware, thus, regardless the setting value of P2-21 (DO Code), the function can work. When using COMPARE, in order to avoid DO error, the system will force to disable DO function, which means the setting will be P2-21 = 0x0100 automatically. Since the value is not written into EEPROM, P2-21 will return to the default value after re-power on.</p>
Output Method	<ul style="list-style-type: none"> ● Pulse output can select contact A/B. ● It is able to continuously output more than one point. ● It can set the pulse output time.
Data Storage Position	<ul style="list-style-type: none"> ● Data array. The start address is set by P5-56.

COMPARE Features	
Compare Number	● It is set via P5-58 and will not exceed the limit of data array.
Compare Format	● 32-bit (It has positive and negative signs.)
Compare Condition	● It will be triggered when the source of compare axis pass through the compare value. (The values can be from great to small or vice versa.)
Auxiliary Selection	<ul style="list-style-type: none"> ● Cycle mode: When comparing to the last point, it automatically returns to the first point and starts to compare. ● When the last compare is completed, the CAPTURE function is activated automatically.
Note	<ul style="list-style-type: none"> ● If P5-58 is set to 0, set the value of P5-59 X, Bit0 to 1 will be unable to compare. Set the value of P5-59 X, Bit0 to 0. ● Since the capture axis is 32-bit wide, the accumulation will cause overflow. Please avoid this.

The value of COMPARE is saved in data array and the first compare data locates in P5-56. The CMP number has no limit, thus it can be set via P5-58. The last CMP data is saved in P5-56 + P5-58 - 1. Set the value of P5-59.X, Bit0 to 1 so as to activate CMP function and start to compare the first data of data array. Every time when a position saved in data array is compared, the compare DO will be outputted. Then, the value of P5-58 will decrease one automatically and compare the next value until the CMP number reaches the setting value (P5-58 = 0). When the CMP procedure is completed, the setting value of P5-59.X, Bit0 will be cleared to 0.

When comparing to the last point, it can select if it returns to the first data for comparing. This is called cycle mode. Or it can activate CAPTURE function and wait D17 for triggering CAP/CMP procedure.

The diagram of COMPARE:

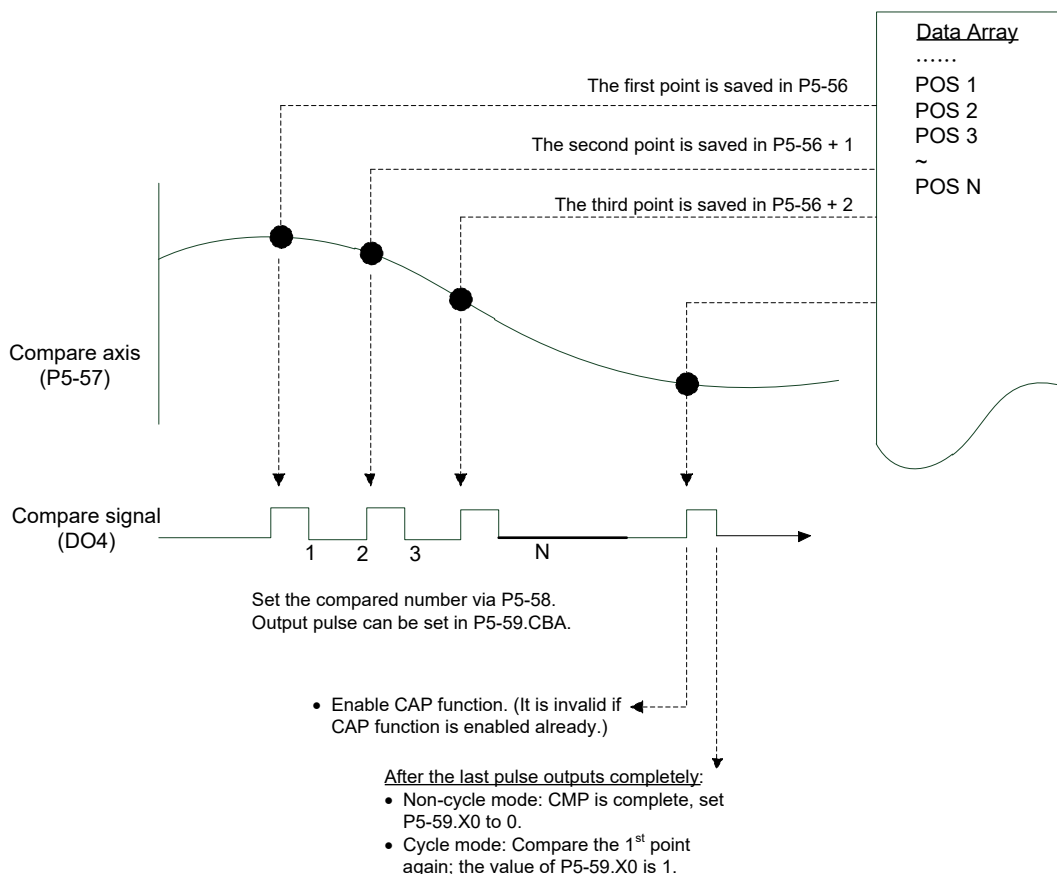

(This page is intentionally left blank.)

Chapter 8 Parameters

8.1 Parameter Definition

Parameters are divided into eight groups which are shown as follows. The first character after the start code P is the group character and the second character is the parameter character.

As for the communication address, it is the combination of group number along with two-digit number in hexadecimal. The definition of parameter groups is as the followings:

Group 0: Monitor parameters	(example: P0-xx)
Group 1: Basic parameters	(example: P1-xx)
Group 2: Extension parameters	(example: P2-xx)
Group 3: Communication parameters	(example: P3-xx)
Group 4: Diagnosis parameters	(example: P4-xx)
Group 5: Motion control parameters	(example: P5-xx)
Group 6: PR parameters	(example: P6-xx)
Group 7: PR parameters	(example: P7-xx)

Control Mode Description:

PT	:	Position control mode (Input the position command via the terminal block)
PR	:	Position control mode (The internal register issues the position command)
S	:	Speed control mode
T	:	Torque control mode
DMC	:	DMCNET control mode

Special Symbol Description

- (★) Read-only register. Can only read the status. For example: parameters P0-00, P0-10, and P4-00, etc.
- (▲) Setting is invalid when Servo On, e.g. parameters P1-00, P1-46, and P2-33, etc.
- (●) Not effective until re-power on or off the servo drive, e.g. parameters P1-01 and P3-00.
- (■) Parameters of no data retained setting, e.g. parameters P2-31 and P3-06.

8.2 List of Parameters

Monitor and General Output Parameter									
Parameter	Abbr.	Function	Default	Unit	Control Mode				Related Section
					PT	PR	S	T	
P0-00★	VER	Firmware Version	Factory Setting	N/A	O	O	O	O	-
P0-01■	ALE	Alarm Code Display of Drive (Seven-segment Display)	N/A	N/A	O	O	O	O	10.1 10.2 10.3
P0-02	STS	Drive Status	00	N/A	O	O	O	O	7.2
P0-03	MON	Analog Output Monitor	0x0	N/A	O	O	O	O	4.3.5
P0-08★	TSON	Servo On Time	0	Hour					-
P0-09★	CM1	Status Monitor Register 1	N/A	N/A	O	O	O	O	4.3.5
P0-10★	CM2	Status Monitor Register 2	N/A	N/A	O	O	O	O	4.3.5
P0-11★	CM3	Status Monitor Register 3	N/A	N/A	O	O	O	O	4.3.5
P0-12★	CM4	Status Monitor Register 4	N/A	N/A	O	O	O	O	4.3.5
P0-13★	CM5	Status Monitor Register 5	N/A	N/A	O	O	O	O	4.3.5
P0-17	CM1A	Status Monitor Register 1 Selection	0	N/A					-
P0-18	CM2A	Status Monitor Register 2 Selection	0	N/A					-
P0-19	CM3A	Status Monitor Register 3 Selection	0	N/A					-
P0-20	CM4A	Status Monitor Register 4 Selection	0	N/A					-
P0-21	CM5A	Status Monitor Register 5 Selection	0	N/A					-
P0-25	MAP1	Mapping Parameter # 1	No need to initialize	N/A	O	O	O	O	4.3.5
P0-26	MAP2	Mapping Parameter # 2	No need to initialize	N/A	O	O	O	O	4.3.5
P0-27	MAP3	Mapping Parameter # 3	No need to initialize	N/A	O	O	O	O	4.3.5
P0-28	MAP4	Mapping Parameter # 4	No need to initialize	N/A	O	O	O	O	4.3.5
P0-29	MAP5	Mapping Parameter # 5	No need to initialize	N/A	O	O	O	O	4.3.5
P0-30	MAP6	Mapping Parameter # 6	No need to initialize	N/A	O	O	O	O	4.3.5
P0-31	MAP7	Mapping Parameter # 7	No need to initialize	N/A	O	O	O	O	4.3.5
P0-32	MAP8	Mapping Parameter # 8	No need to initialize	N/A	O	O	O	O	4.3.5

Monitor and General Output Parameter									
Parameter	Abbr.	Function	Default	Unit	Control Mode				Related Section
					PT	PR	S	T	
P0-35	MAP1A	Target Setting of Mapping Parameter P0-25	0x0	N/A	O	O	O	O	4.3.5
P0-36	MAP2A	Target Setting of Mapping Parameter P0-26	0x0	N/A	O	O	O	O	4.3.5
P0-37	MAP3A	Target Setting of Mapping Parameter P0-27	0x0	N/A	O	O	O	O	4.3.5
P0-38	MAP4A	Target Setting of Mapping Parameter P0-28	0x0	N/A	O	O	O	O	4.3.5
P0-39	MAP5A	Target Setting of Mapping Parameter P0-29	0x0	N/A	O	O	O	O	4.3.5
P0-40	MAP6A	Target Setting of Mapping Parameter P0-30	0x0	N/A	O	O	O	O	4.3.5
P0-41	MAP7A	Target Setting of Mapping Parameter P0-31	0x0	N/A	O	O	O	O	4.3.5
P0-42	MAP8A	Target Setting of Mapping Parameter P0-32	0x0	N/A	O	O	O	O	4.3.5
P0-46★	SVSTS	Servo Digital Output Status Display	0x0	N/A	O	O	O	O	-
P1-04	MON1	MON1 Analog Monitor Output Proportion	100	%(full scale)	O	O	O	O	6.6.3
P1-05	MON2	MON2 Analog Monitor Output Proportion	100	%(full scale)	O	O	O	O	6.6.3

- (★) Read-only register. Can only read the status. For example: parameters P0-00, P0-10, and P4-00, etc.
- (▲) Setting is invalid when Servo On, e.g. parameters P1-00, P1-46, and P2-33, etc.
- (●) Not effective until re-power on or off the servo drive, e.g. parameters P1-01 and P3-00.
- (■) Parameters of no data retained setting, e.g. parameters P2-31 and P3-06.

Filter and Resonance Suppression Parameter									
Parameter	Abbr.	Function	Default	Unit	Control Mode				Related Section
					PT	PR	S	T	
P1-06	SFLT	Analog Speed Command (Low-pass Filter)	0	ms			O		6.3.3
P1-07	TFLT	Analog Torque Command (Low-pass Filter)	0	ms				O	6.4.3
P1-08	PFLT	Smooth Constant of Position Command (Low-pass Filter)	0	10 ms	O	O			6.2.6
P1-25	VSF1	Low-frequency Vibration Suppression (1)	1000	0.1 Hz	O	O			6.2.9
P1-26	VSG1	Low-frequency Vibration Suppression Gain (1)	0	N/A	O	O			6.2.9
P1-27	VSF2	Low-frequency Vibration Suppression (2)	1000	0.1 Hz	O	O			6.2.9
P1-28	VSG2	Low-frequency Vibration Suppression Gain (2)	0	N/A	O	O			6.2.9
P1-29	AVSM	Auto Low-frequency Vibration Suppression Setting	0	N/A	O	O			6.2.9
P1-30	VCL	Low-frequency Vibration Detection	500	pulse	O	O			6.2.9
P1-34	TACC	Acceleration Constant of S-Curve	200	ms			O		6.3.3
P1-35	TDEC	Deceleration Constant of S-Curve	200	ms			O		6.3.3
P1-36	TSL	Acceleration / Deceleration Constant of S-Curve	0	ms		O	O		6.3.3
P1-59	MFLT	Analog Speed Command	0	0.1 ms			O		-
P1-62	FRCL	Friction Compensation	0	%	O	O	O	O	-
P1-63	FRCT	Friction Compensation	0	ms	O	O	O	O	-
P1-68	PFLT2	Position Command Moving Filter	4	ms	O	O			-
P1-75	FELP	Low-pass Filter Time Constant of Full-closed Loop control	100	ms	O	O			-
P2-23	NCF1	Resonance suppression (Notch filter) (1)	1000	Hz	O	O	O	O	6.3.7
P2-24	DPH1	Resonance Suppression (Notch filter) Attenuation Rate (1)	0	dB	O	O	O	O	6.3.7
P2-43	NCF2	Resonance suppression (Notch filter) (2)	1000	Hz	O	O	O	O	6.3.7
P2-44	DPH2	Resonance Suppression (Notch filter) Attenuation Rate (2)	0	dB	O	O	O	O	6.3.7
P2-45	NCF3	Resonance suppression (Notch filter) (3)	1000	Hz	O	O	O	O	6.3.7

Filter and Resonance Suppression Parameter									
Parameter	Abbr.	Function	Default	Unit	Control Mode				Related Section
					PT	PR	S	T	
P2-46	DPH3	Resonance Suppression (Notch filter) Attenuation Rate (3)	0	dB	O	O	O	O	6.3.7
P2-47	ANCF	Auto Resonance Suppression Mode Setting	1	N/A	O	O	O	O	-
P2-48	ANCL	Resonance Suppression Detection Level	100	N/A	O	O	O	O	-
P2-25	NLP	Low-pass Filter of Resonance Suppression	2 or 5	0.1ms	O	O	O	O	6.3.7
P2-33▲	INF	Semi-auto Inertia Adjustment	0x0	N/A	O	O	O	O	-
P2-49	SJIT	Speed Detection Filter	0x0	N/A	O	O	O	O	-

- (★) Read-only register. Can only read the status. For example: parameters P0-00, P0-10, and P4-00, etc.
- (▲) Setting is invalid when Servo On, e.g. parameters P1-00, P1-46, and P2-33, etc.
- (●) Not effective until re-power on or off the servo drive, e.g. parameters P1-01 and P3-00.
- (■) Parameters of no data retained setting, e.g. parameters P2-31 and P3-06.

Gain and Switch Parameter									
Parameter	Abbr.	Function	Default	Unit	Control Mode				Related Section
					PT	PR	S	T	
P2-00	KPP	Position Loop Gain	35	rad/s	O	O			6.2.8
P2-01	PPR	Switching Rate of Position Loop Gain	100	%	O	O			
P2-02	PFG	Position Control Feed Forward Gain	50	%	O	O			6.2.8
P2-03	PFF	Smooth Constant of Position Feed Forward Gain	5	ms	O	O			-
P2-04	KVP	Speed Control Gain	500	rad/s	O	O	O	O	6.3.6
P2-05	SPR	Switching Rate of Speed Control Gain	100	%	O	O	O	O	-
P2-06	KVI	Speed Integral Compensation	100	rad/s	O	O	O	O	6.3.6
P2-07	KVF	Speed Feed Forward Gain	0	%	O	O	O	O	6.3.6
P2-26	DST	Anti-interference Gain	0	rad/s	O	O	O	O	-
P2-27	GCC	Gain Switching and Switching Selection	0x0	N/A	O	O	O	O	-
P2-28	GUT	Gain Switching Time Constant	10	10 ms	O	O	O	O	-

Gain and Switch Parameter									
Parameter	Abbr.	Function	Default	Unit	Control Mode				Related Section
P2-29	GPE	Gain Switching	1280000	pulse Kpps r/min	O	O	O	O	-
P2-31■	AUT1	Speed Loop Frequency Response Setting in Auto and Semi-auto Mode	40	Hz	O	O	O	O	5.6 6.3.6
P2-32▲	AUT2	Tuning Mode Selection	0x0	N/A	O	O	O	O	5.6 6.3.6

(★) Read-only register. Can only read the status. For example: parameters P0-00, P0-10, and P4-00, etc.

(▲) Setting is unable when Servo On, e.g. parameters P1-00, P1-46, and P2-33, etc.

(●) Not effective until re-power on or off the servo drive, e.g. parameters P1-01 and P3-00.

(■) Parameters of no data retained setting, e.g. parameters P2-31 and P3-06.

Position Control Parameter									
Parameter	Abbr.	Function	Default	Unit	Control Mode				Related Section
					PT	PR	S	T	
P1-01●	CTL	Input Setting of Control Mode and Control Command	0*	-	O	O	O	O	6.1
P1-02▲	PSTL	Speed and Torque Limit Setting	0x0	N/A	O	O	O	O	6.6
P1-12 ~ P1-14	TQ1 ~ 3	Internal Torque Limit 1 ~ 3	100	%	O	O	O	O	6.4.1
P1-46▲	GR3	Pulse Number of Encoder Output	2500	pulse	O	O	O	O	-
P1-55	MSPD	Maximum Speed Setting	rated	r/min	O	O	O	O	-
P1-72	FRES	Resolution of Linear Scale for full-closed loop control	5000	Pulse/ rev	O	O			-
P1-73	FERR	Error Protection Range for Full-closed Loop Control	30000	pulse	O	O			-
P1-74	FCON	Full-closed Loop Control of Linear Scale	000h	-	O	O			-
P2-50	DCLR	Pulse Clear Mode	0	N/A	O	O			-
P5-03	PDEC	Deceleration Time of Auto Protection	0XF00FFFFF	N/A	O	O	O	O	-
P5-20 ~ P5-35	AC0 ~ AC15	Acceleration / Deceleration Time	30 ~ 8000	ms	O	O	O	O	7.10
P5-16	AXEN	Axis Position - Motor Encoder	N/A	N/A	O	O	O	O	7.3
P5-17	AXAU	Axis Position - Auxiliary Encoder	N/A	N/A	O	O	O	O	7.3
P5-18	AXPC	Axis Position - Pulse Command	N/A	N/A	O	O	O	O	7.3

Position Control Parameter									
Parameter	Abbr.	Function	Default	Unit	Control Mode				Related Section
					PT	PR	S	T	
External Pulse Command (PT mode)									
P1-00▲	PTT	External Pulse Input Type	0x2	N/A	O				6.2.1
P1-44▲	GR1	Gear Ratio (Numerator) (N1)	128	pulse	O	O			6.2.5
P1-45▲	GR2	Gear Ratio (Denominator) (M)	10	pulse	O	O			6.2.5
P2-60	GR4	Gear Ratio (Numerator) (N2)	128	pulse	O				-
P2-61	GR5	Gear Ratio (Numerator) (N3)	128	pulse	O				-
P2-62	GR6	Gear Ratio (Numerator) (N4)	128	pulse	O				-
Register Control Command (PR mode)									
P6-02 ~ P7-27	PO1 ~ PO63	Internal Position Command 1 ~ 63	0	N/A		O			7.10
P5-60 ~ P5-75	POV1 ~ POV15	Target Speed Setting #0 ~ 15	20 ~ 3000	0.1r/min		O			7.10
P5-04	HMOV	Homing Mode	0x0	N/A		O			-
P5-05	HSPD1	1 st Speed Setting of High Speed Homing	100	r/min		O			-
P5-06	HSPD2	2 nd Speed Setting of Low Speed Homing	20	r/min		O			-
P5-07	PRCM	Trigger Position Command (PR mode only)	0	N/A		O			-
P5-40 ~ P5-55	DLY0 ~ DLY15	Delay Time after Position Completed	0 ~ 5500	ms		O			7.10
P5-98	EVON	Position Command of Event Rising-edge Trigger	0x0	N/A		O			-
P5-99	EVOF	Position Command of Event Falling-edge Trigger	0x0	N/A		O			-
P5-15	PMEM	PATH#1 ~ PATH#2 No Data Retained Setting	0x0	N/A		O			-
P5-08	SWLP	Forward Software Limit	+2 ³¹	PUU		O			-
P5-09	SWLN	Reverse Software Limit	-2 ³¹	PUU		O			-

(★) Read-only register. Can only read the status. For example: parameters P0-00, P0-10, and P4-00, etc.

(▲) Setting is invalid when Servo On, e.g. parameters P1-00, P1-46, and P2-33, etc.

(●) Not effective until re-power on or off the servo drive, e.g. parameters P1-01 and P3-00.

(■) Parameters of no data retained setting, e.g. parameters P2-31 and P3-06.

Note: (*) please refer to the detailed description of the parameter.

Speed Control Parameter									
Parameter	Abbr.	Function	Default	Unit	Control Mode				Related Section
					PT	PR	S	T	
P1-01●	CTL	Input Setting of Control Mode and Control Command	0*	pulse r/min N-M	O	O	O	O	6.1
P1-02▲	PSTL	Speed and Torque Limit Setting	0x0	N/A	O	O	O	O	6.6
P1-46▲	GR3	Output Pulse Counts Per One Motor Revolution	2500	pulse	O	O	O	O	-
P1-55	MSPD	Maximum Speed Limit	rated	r/min	O	O	O	O	-
P1-09 ~ P1-11	SP1 ~ 3	Internal Speed Command 1 ~ 3	1000 ~ 3000	0.1 r/min			O	O	6.3.1
P1-12 ~ P1-14	TQ1 ~ 3	Internal Torque Limit 1 ~ 3	100	%	O	O	O	O	6.6.2
P1-40▲	VCM	Maximum Speed of Analog Speed Command	rated	r/min			O	O	6.3.4
P1-41▲	TCM	Maximum Output of Analog Torque Speed	100	%	O	O	O	O	-
P1-76	AMSPD	Maximum Rotation Setting of Encoder Setting (OA, OB)	5500	r/min	O	O	O	O	-

(★) Read-only register. Can only read the status. For example: parameters P0-00, P0-10, and P4-00, etc.

(▲) Setting is invalid when Servo On, e.g. parameters P1-00, P1-46, and P2-33, etc.

(●) Not effective until re-power on or off the servo drive, e.g. parameters P1-01 and P3-00.

(■) Parameters of no data retained setting, e.g. parameters P2-31 and P3-06.

Note: (*) please refer to the detailed description of the parameter.

Torque Control Parameter									
Parameter	Abbr.	Function	Default	Unit	Control Mode				Related Section
					PT	PR	S	T	
P1-01●	CTL	Input Setting of Control Mode and Control Command	0*	pulse r/min N-M	O	O	O	O	6.1
P1-02▲	PSTL	Speed and Torque Limit Setting	0x0	N/A	O	O	O	O	6.6
P1-46▲	GR3	Output Pulse Counts Per One Motor Revolution	2500	pulse	O	O	O	O	-
P1-55	MSPD	Maximum Speed Limit	rated	r/min	O	O	O	O	-
P1-09 ~ P1-11	SP1~3	Internal Speed Limit 1~3	1000 ~ 3000	r/min			O	O	6.6.1
P1-12 ~ P1-14	TQ1~3	Internal Torque Command 1~3	100	%	O	O	O	O	6.4.1
P1-40▲	VCM	Maximum Speed of Analog Speed Command	rated	r/min			O	O	-
P1-41▲	TCM	Maximum Output of Analog Torque Limit	100	%	O	O	O	O	6.4.4

(★) Read-only register. Can only read the status. For example: parameters P0-00, P0-10, and P4-00, etc.

(▲) Setting is invalid when Servo On, e.g. parameters P1-00, P1-46, and P2-33, etc.

(●) Not effective until re-power on or off the servo drive, e.g. parameters P1-01 and P3-00.

(■) Parameters of no data retained setting, e.g. parameters P2-31 and P3-06.

Note: (*) please refer to the detailed description of the parameter.

Planning of Digital Input / Output Pin and Output Setting Parameter									
Parameter	Abbr.	Function	Default	Unit	Control Mode				Related Section
					PT	PR	S	T	
P0-53	ZDRT	General Range Compare Digital Output – Filtering Time	0x0	ms	O	O	O	O	-
P0-54	ZON1L	General Range Compare Digital Output – Lower Limit of 1st Monitoring Variable	0	N/A	O	O	O	O	-
P0-55	ZON1H	General Range Compare Digital Output – Upper Limit of 1st Monitoring Variable	0	N/A	O	O	O	O	-
P2-09	DRT	DI Debouncing Time	2	ms	O	O	O	O	-
P2-10	DI1	DI1 Functional Planning	0x0101	N/A	O	O	O	O	Table 8.1
P2-11	DI2	DI2 Functional Planning	0x0104	N/A	O	O	O	O	Table 8.1

Planning of Digital Input / Output Pin and Output Setting Parameter									
Parameter	Abbr.	Function	Default	Unit	Control Mode				Related Section
					PT	PR	S	T	
P2-12	DI3	DI3 Functional Planning	0x0116	N/A	O	O	O	O	Table 8.1
P2-13	DI4	DI4 Functional Planning	0x0117	N/A	O	O	O	O	Table 8.1
P2-14	DI5	DI5 Functional Planning	0x0102	N/A	O	O	O	O	Table 8.1
P2-15	DI6	DI6 Functional Planning	0x0022	N/A	O	O	O	O	Table 8.1
P2-16	DI7	DI7 Functional Planning	0x0023	N/A	O	O	O	O	Table 8.1
P2-17	DI8	DI8 Functional Planning	0x0021	N/A	O	O	O	O	Table 8.1
P2-36	EDI9	DI9 Functional Planning	0x0	N/A	O	O	O	O	Table 8.1
P2-37	EDI10	DI10 Functional Planning	0x0	N/A	O	O	O	O	Table 8.1
P2-38	EDI11	DI11 Functional Planning	0x0	N/A	O	O	O	O	Table 8.1
P2-39	EDI12	DI12 Functional Planning	0x0	N/A	O	O	O	O	Table 8.1
P2-40	EDI13	DI13 Functional Planning	0x0	N/A	O	O	O	O	Table 8.1
P2-41	EDI14	DI14 Functional Planning	0x0	N/A	O	O	O	O	Table 8.1
P2-18	DO1	DO1 Functional Planning	0x0101	N/A	O	O	O	O	Table 8.2
P2-19	DO2	DO2 Functional Planning	0x0103	N/A	O	O	O	O	Table 8.2
P2-20	DO3	DO3 Functional Planning	0x0109	N/A	O	O	O	O	Table 8.2
P2-21	DO4	DO4 Functional Planning	0x0105	N/A	O	O	O	O	Table 8.2
P2-22	DO5	DO5 Functional Planning	0x0007	N/A	O	O	O	O	Table 8.2
P1-38	ZSPD	Zero Speed Range Setting	100	0.1 r/min	O	O	O	O	Table 8.2
P1-39	SSPD	Target Motor Detection Level	3000	r/min	O	O	O	O	Table 8.2
P1-42	MBT1	Enable Delay Time of Brake	0	ms	O	O	O	O	6.6.4
P1-43	MBT2	Disable Delay Time of Brake	0	ms	O	O	O	O	6.6.4
P1-47	SCPD	Speed Reached (DO: SP_OK) Range	10	r/min			O		Table 8.2

Planning of Digital Input / Output Pin and Output Setting Parameter									
Parameter	Abbr.	Function	Default	Unit	Control Mode				Related Section
					PT	PR	S	T	
P1-54	PER	Position Completed Range	12800	pulse	O	O			Table 8.2
P1-56	OVW	Output Overload Warning Level	120	%	O	O	O	O	Table 8.2

- (★) Read-only register. Can only read the status. For example: parameters P0-00, P0-10, and P4-00, etc.
- (▲) Setting is invalid when Servo On, e.g. parameters P1-00, P1-46, and P2-33, etc.
- (●) Not effective until re-power on or off the servo drive, e.g. parameters P1-01 and P3-00.
- (■) Parameters of no data retained setting, e.g. parameters P2-31 and P3-06.

Communication Parameter									
Parameter	Abbr.	Function	Default	Unit	Control Mode				Related Section
					PT	PR	S	T	
P3-00●	ADR	Address Setting	0x007F	N/A	O	O	O	O	9.2
P3-01	BRT	Transmission Speed	0x3203	bps	O	O	O	O	9.2
P3-02	PTL	Communication Protocol	0x6	N/A	O	O	O	O	9.2
P3-03	FLT	Communication Error Disposal	0	N/A	O	O	O	O	9.2
P3-04	CWD	Communication Timeout	0	sec	O	O	O	O	9.2
P3-05	CMM	Communication Mechanism	0x0	N/A	O	O	O	O	9.2
P3-06■	SDI	Control Switch of Digital Input (DI)	0x0	N/A	O	O	O	O	9.2
P3-07	CDT	Communication Response Delay Time	0	ms	O	O	O	O	9.2
P3-09	SYC	CANopen Synchronize Setting	0x50557A1	N/A					
P3-09	SYC	DMCNET Synchronize Setting	0x3511	N/A					
		CANopen Protocol Setting	0x5055						
P3-10	CANEN	DMCNET Protocol Setting	0x0001	N/A					
		CANopen Selection	0x0000						
P3-12	QSTPO	DMCNET Selection	0	N/A					
		CANopen Support Setting	0						

- (★) Read-only register. Can only read the status. For example: parameters P0-00, P0-10, and P4-00, etc.
- (▲) Setting is invalid when Servo On, e.g. parameters P1-00, P1-46, and P2-33, etc.
- (●) Not effective until re-power on or off the servo drive, e.g. parameters P1-01 and P3-00.
- (■) Parameters of no data retained setting, e.g. parameters P2-31 and P3-06.

Diagnosis Parameter									
Parameter	Abbr.	Function	Default	Unit	Control Mode				Related Section
					PT	PR	S	T	
P4-00★	ASH1	Fault Record (N)	0x0	N/A	○	○	○	○	4.4.1
P4-01★	ASH2	Fault Record (N-1)	0x0	N/A	○	○	○	○	4.4.1
P4-02★	ASH3	Fault Record (N-2)	0x0	N/A	○	○	○	○	4.4.1
P4-03★	ASH4	Fault Record (N-3)	0x0	N/A	○	○	○	○	4.4.1
P4-04★	ASH5	Fault Record (N-4)	0x0	N/A	○	○	○	○	4.4.1
P4-05	JOG	Servo Motor Jog Control	20	r/min	○	○	○	○	4.4.2
P4-06■	FOT	Digital Output Register (Readable and Writable)	0x0	N/A	○	○	○	○	4.4.5
P4-07	ITST	Multi-function of Digital Input	0x0	N/A	○	○	○	○	4.4.5
P4-08★	PKEY	Input Status of the Drive Keypad	N/A	N/A	○	○	○	○	-
P4-09★	MOT	Digital Output Status	N/A	N/A	○	○	○	○	4.4.5
P4-10▲	CEN	Adjustment Selection	0	N/A	○	○	○	○	-
P4-11	SOF1	Analog Speed Input Offset Adjustment 1	Factory Setting	N/A	○	○	○	○	-
P4-12	SOF2	Analog Speed Input Offset Adjustment 2	Factory Setting	N/A	○	○	○	○	-
P4-13	TOF1	Analog Torque Input Offset Adjustment 1	Factory Setting	N/A	○	○	○	○	-
P4-14	TOF2	Analog Torque Input Offset Adjustment 2	Factory Setting	N/A	○	○	○	○	-
P4-15	COF1	Current Detector (V1 Phase) Offset Adjustment	Factory Setting	N/A	○	○	○	○	-
P4-16	COF2	Current Detector (V2 Phase) Offset Adjustment	Factory Setting	N/A	○	○	○	○	-
P4-17	COF3	Current Detector (W1 Phase) Offset Adjustment	Factory Setting	N/A	○	○	○	○	-
P4-18	COF4	Current Detector (W2 Phase) Offset Adjustment	Factory Setting	N/A	○	○	○	○	-
P4-19	TIGB	IGBT NTC Adjustment Detection Level	Factory Setting	N/A	○	○	○	○	-
P4-20	DOF1	Offset Adjustment Value of Analog Monitor Output (Ch1)	0	mV	○	○	○	○	6.6.3
P4-21	DOF2	Offset Adjustment Value of Analog Monitor Output (Ch2)	0	mV	○	○	○	○	6.6.3
P4-22	SAO	Analog Speed Input OFFSET	0	mV			○		-
P4-23	TAO	Analog Torque Input OFFSET	0	mV				○	-

(★) Read-only register. Can only read the status. For example: parameters P0-00, P0-10, and P4-00, etc.

(▲) Setting is invalid when Servo On, e.g. parameters P1-00, P1-46, and P2-33, etc.

- (●) Not effective until re-power on or off the servo drive, e.g. parameters P1-01 and P3-00.
- (■) Parameters of no data retained setting, e.g. parameters P2-31 and P3-06.

8.3 Parameter Description

P0-xx Monitor Parameters

P0-00★	VER	Firmware Version		Address: 0000H 0001H
	Operational Interface :	Panel / Software	Communication	Related Section: -
	Default :	Factory Setting		
	Control Mode :	ALL		
	Unit :	-		
	Range :	-		
	Data Size :	16-bit		
	Format :	Decimal		

Settings : This parameter shows the firmware version of the servo drive.

P0-01■	ALE	Alarm Code Display of Drive (Seven-segment Display)		Address: 0002H 0003H
	Operational Interface :	Panel / Software	Communication	Related Section: 10.1, 10.2, 10.3
	Default :	-		
	Control Mode :	ALL		
	Unit :	-		
	Range :	0x0000		
	Data Size :	16-bit		
	Format :	Hexadecimal		

Settings : Hexadecimal format: displays the alarm code
 0x0000: alarm cleared (same as DI.ARST)
 0x0000 ~ 0xFFFF: display the current alarm (read-only)
 For the alarm list, please refer to Section 10.1.

P0-02	STS	Drive Status		Address: 0004H 0005H
	Operational Interface :	Panel / Software	Communication	Related Section: 7.2
	Default :	00		
	Control Mode :	ALL		
	Unit :	-		
	Range :	0 ~ 127		
	Data Size :	16-bit		
	Format :	Decimal		

Settings : Displays the parameter setting. You can set the monitoring variable for P0-02 to monitor the variable through the panel. Please refer to Section 7.2.1 Monitoring Variables.

P0-03	MON	Analog Output Monitor		Address: 0006H 0007H
	Operational Interface :	Panel / Software	Communication	Related Section: 6.6.4
	Default :	0x0000		
	Control Mode :	ALL		
	Unit :	-		
	Range :	0x0000 ~ 0x0077		
	Data Size :	16-bit		
	Format :	Hexadecimal		

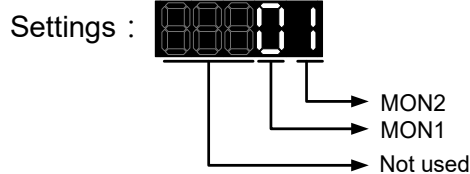

MON1, MON2 Setting Value	Description
0	Motor speed (+/-8 Volts/Max. speed)
1	Motor torque (+/-8 Volts/Max. torque)
2	Pulse command frequency (+8 Volts / 4.5 Mpps)
3	Speed command (+/-8 Volts/ Max. speed command)
4	Torque command (+/-8 Volts/Max. torque command)
5	VBUS voltage (+/-8 Volts / 450V)
6	Reserved
7	Reserved

Note: Please refer to parameter P1-04 and P1-05 for proportional setting of analog output voltage.

For example: P0-03 = 01 (MON1 is the analog output of motor speed; MON2 is the analog output of motor torque)

$$\text{MON1 output voltage} = 8 \times \frac{\text{Motor speed}}{(\text{Max. speed} \times \frac{P1-04}{100})} \text{ (unit: Volts)}$$

$$\text{MON2 output voltage} = 8 \times \frac{\text{Motor torque}}{(\text{Max. torque} \times \frac{P1-05}{100})} \text{ (unit: Volts)}$$

P0-04 ~ P0-07	Reserved
--------------------------	-----------------

P0-08★	TSON	Power On Time	Address: 0010H 0011H
Operational Interface :	Panel / Software	Communication	Related Section: -
Default :	0		
Control Mode :	-		
Unit :	Hour		
Range :	0 ~ 65535		
Data Size :	16-bit		
Format :	Decimal		

Settings : It shows the total startup time of the servo drive.

P0-09★	CM1	Status Monitor Register 1	Address: 0012H 0013H
Operational Interface :	Panel / Software	Communication	Related Section: 4.3.5
Default :	-		
Control Mode :	ALL		
Unit :	-		
Range :	-		
Data Size :	32-bit		
Format :	Decimal		

Settings : Set the value to be monitored in P0-17 through the drive panel or communication. (Please refer to Chapter 7.2.1, Description of Monitoring Variable for the setting value.) To get the status, the communication port must read the communication address.

For example, if P0-17 is set to 3, when accessing P0-09, it obtains the total feedback pulse number of motor encoder. For MODBUS communication, two 16-bit data, 0012H and 0013H will be read as a 32-bit data; (0013H : 0012H) = (Hi-word : Low-word).

Set P0-02 to 23, the panel displays **VAR-1** first, and then shows the content of P0-09.

P0-10★	CM2	Status Monitor Register 2	Address: 0014H 0015H
Operational Interface :	Panel / Software	Communication	Related Section: 4.3.5
Default :	-		
Control Mode :	ALL		
Unit :	-		
Range :	-		
Data Size :	32-bit		
Format :	Decimal		

Settings : Set the value to be monitored in P0-18 through the drive panel or communication. (Please refer to section 7.2.1, Description of Monitoring variable for the setting value.) To get the status, the communication port must read the communication address. Set P0-02 to 24, the panel displays **VAR-2** first, and then shows the content of P0-10.

P0-11★	CM3	Status Monitor Register 3		Address: 0016H 0017H
	Operational Interface :	Panel / Software	Communication	Related Section: 4.3.5
	Default :	-		
	Control Mode :	ALL		
	Unit :	-		
	Range :	-		
	Data Size :	32-bit		
	Format :	Decimal		

Settings : Set the value to be monitored in P0-19 through the drive panel or communication. (Please refer to section 7.2.1, Description of Monitoring Variable for the setting value.) To get the status, the communication port must read the communication address. Set P0-02 to 25, the panel displays **VAR-3** first, and then shows the content of P0-11.

P0-12★	CM4	Status Monitor Register 4		Address: 0018H 0019H
	Operational Interface :	Panel / Software	Communication	Related Section: 4.3.5
	Default :	-		
	Control Mode :	ALL		
	Unit :	-		
	Range :	-		
	Data Size :	32-bit		
	Format :	Decimal		

Settings : Set the value to be monitored in P0-20 through the drive panel or communication. (Please refer to section 7.2.1, Description of Monitoring Variable for the setting value.) To get the status, the communication port must read the communication address. Set P0-02 to 26, the panel displays **VAR-4** first, and then shows the content of P0-12.

P0-13★	CM5	Status Monitor Register 5	Address: 001AH 001BH
Operational Interface :	Panel / Software	Communication	Related Section: 4.3.5
Default :	-		
Control Mode :	ALL		
Unit :	-		
Range :	-		
Data Size :	32-bit		
Format :	Decimal		

Settings : Set the value to be monitored in P0-21 through the drive panel or communication. (Please refer to section 7.2.1, Description of Monitoring Variable for the setting value.) To get the status, the communication port must read the communication address.

P0-14 ~ P0-16	Reserved

P0-17	CM1A	Status Monitor Register 1 Selection	Address: 0022H 0023H
Operational Interface :	Panel / Software	Communication	Related Section: -
Default :	0		
Control Mode :	-		
Unit :	-		
Range :	0 ~ 127		
Data Size :	16-bit		
Format :	Decimal		

Settings : Please refer to section 7.2.1, Description of Monitoring Variable for the setting value.

For example, if P0-17 is set to 07, then reading P0-09 means reading "Motor speed (r/min)."

P0-18	CM2A	Status Monitor Register 2 Selection	Address: 0024H 0025H
Operational Interface :	Panel / Software	Communication	Related Section: -
Default :	0		
Control Mode :	-		
Unit :	-		
Range :	0 ~ 127		
Data Size :	16-bit		
Format :	Decimal		

Settings : Please refer to section 7.2.1, Description of Monitoring Variable for the setting value.

P0-19	CM3A	Status Monitor Register 3 Selection	Address: 0026H 0027H
	Operational Interface :	Panel / Software	Communication
	Default :	0	
	Control Mode :	-	
	Unit :	-	
	Range :	0 ~ 127	
	Data Size :	16-bit	
	Format :	Decimal	
	Settings :	Please refer to section 7.2.1, Description of Monitoring Variable for the setting value.	
			Related Section: -

P0-20	CM4A	Status Monitor Register 4 Selection	Address: 0028H 0029H
	Operational Interface :	Panel / Software	Communication
	Default :	0	
	Control Mode :	-	
	Unit :	-	
	Range :	0 ~ 127	
	Data Size :	16-bit	
	Format :	Decimal	
	Settings :	Please refer to section 7.2.1, Description of Monitoring Variable for the setting value.	
			Related Section: -

P0-21	CM5A	Status Monitor Register 5 Selection	Address: 002AH 002BH
	Operational Interface :	Panel / Software	Communication
	Default :	0	
	Control Mode :	-	
	Unit :	-	
			Related Section: -

Range :	0 ~ 127
Data Size :	16-bit
Format :	Decimal

Settings : Please refer to section 7.2.1, Description of Monitoring Variable for the setting value.

**P0-22 ~
P0-24**

Reserved

P0-25

MAP1	Mapping Parameter # 1		Address: 0032H 0033H
Operational Interface :	Panel / Software	Communication	Related Section: 4.3.5
Default :	No need to initialize		
Control Mode :	ALL		
Unit :	-		
Range :	determined by the corresponding parameter of P0-35		
Data Size :	32-bit		
Format :	Hexadecimal		

Settings : Users can rapidly continuously read and write parameters that are not in the same group. You can use P0-35 to specify the mapping parameter number through the panel or communication. The content of parameter that is specified by P0-35 will be shown in P0-25. Please refer to the description of P0-35 for parameter setting.

P0-26

MAP2	Mapping Parameter # 2		Address: 0034H 0035H
Operational Interface :	Panel / Software	Communication	Related Section: 4.3.5
Default :	No need to initialize		
Control Mode :	ALL		
Unit :	-		
Range :	determined by the corresponding parameter of P0-36		
Data Size :	32-bit		

Format :	Hexadecimal
----------	-------------

Settings : The using method is the same as P0-25. The mapping target is set by parameter P0-36.

P0-27	MAP3	Mapping Parameter # 3	Address: 0036H 0037H
	Operational Interface :	Panel / Software	Communication
	Default :	No need to initialize	
	Control Mode :	ALL	
	Unit :	-	
	Range :	determined by the corresponding parameter of P0-37	
	Data Size :	32-bit	
	Format :	Hexadecimal	

Related Section:
4.3.5

Settings : The using method is the same as P0-25. The mapping target is set by parameter P0-37.

P0-28	MAP4	Mapping Parameter # 4	Address: 0038H 0039H
	Operational Interface :	Panel / Software	Communication
	Default :	No need to initialize	
	Control Mode :	ALL	
	Unit :	-	
	Range :	determined by the corresponding parameter of P0-38	
	Data Size :	32-bit	
	Format :	Hexadecimal	

Related Section:
4.3.5

Settings : The using method is the same as P0-25. The mapping target is set by parameter P0-38.

P0-29	MAP5	Mapping Parameter # 5		Address: 003AH 003BH
	Operational Interface :	Panel / Software	Communication	Related Section: 4.3.5
	Default :	No need to initialize		
	Control Mode :	ALL		
	Unit :	-		
	Range :	determined by the corresponding parameter of P0-39		
	Data Size :	32-bit		
	Format :	Hexadecimal		

Settings : The using method is the same as P0-25. The mapping target is set by parameter P0-39.

P0-30	MAP6	Mapping Parameter # 6		Address: 003CH 003DH
	Operational Interface :	Panel / Software	Communication	Related Section: 4.3.5
	Default :	No need to initialize		
	Control Mode :	ALL		
	Unit :	-		
	Range :	determined by the corresponding parameter of P0-40		
	Data Size :	32-bit		
	Format :	Hexadecimal		

Settings : The using method is the same as P0-25. The mapping target is set by parameter P0-40.

P0-31	MAP7	Mapping Parameter # 7		Address: 003EH 003FH
	Operational Interface :	Panel / Software	Communication	Related Section: 4.3.5
	Default :	No need to initialize		
	Control Mode :	ALL		

Unit :	-
Range :	determined by the corresponding parameter of P0-41
Data Size :	32-bit
Format :	Hexadecimal

Settings : The using method is the same as P0-25. The mapping target is set by parameter P0-41.

P0-32	MAP8	Mapping Parameter # 8		Address: 0040H 0041H
	Operational Interface :	Panel / Software	Communication	Related Section: 4.3.5
	Default :	No need to initialize		
	Control Mode :	ALL		
	Unit :	-		
	Range :	determined by the corresponding parameter of P0-42		
	Data Size :	32-bit		
	Format :	Hexadecimal		
	Settings : The using method is the same as P0-25. The mapping target is set by parameter P0-42.			

P0-33 ~ P0-34	Reserved
--------------------------	-----------------

P0-35	MAP1A	Target Setting of Mapping Parameter P0-25		Address: 0046H 0047H
	Operational Interface :	Panel / Software	Communication	Related Section: 4.3.5
	Default :	0x00000000		
	Control Mode :	ALL		
	Unit :	-		
	Range :	determined by the communication address of the parameter group		
	Data Size :	32-bit		
	Format :	Hexadecimal		

Settings : Select the data block to access the parameter corresponded by register 1.

The mapping content is 32 bits wide and can map to two 16-bit parameters or one 32-bit parameter.

P0-35:

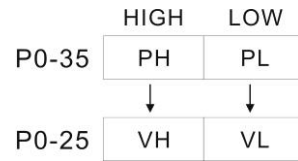

Mapping parameter: P0-35; Mapping content: P0-25.

When PH≠PL, it means the content of P0-25 includes two 16-bit parameters.

VH=*(PH), VL=*(PL)

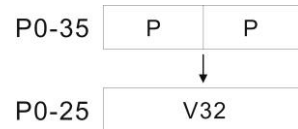

Mapping parameter: P0-35; Mapping content: P0-25.

When PH=PL=P, it means the content of P0-25 includes one 32-bit parameter.

If P=060Ah (parameter P6-10), then V32 is P6-10.

The setting format of PH, PL is:

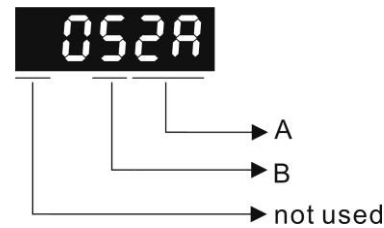

A: The hexadecimal of parameter indexing

B: The hexadecimal of parameter group

For example:

If the mapping target is P2-06, set P0-35 to 0206.

If the mapping target is P5-42, set P0-35 to 052A.

For example:

If users desire to read / write P1-44 (32-bit) through P0-25, set P0-35 to 0x012C012C via panel or communication. Then, when reading / writing P0-25, it also reads / writes P1-44.

Moreover, users can also access the value of P2-02 and P2-04 through P0-25.

P2-02 Position feed forward gain (16-bit)

P2-04 Speed control gain (16-bit)

Users only need to set P0-35 to 0x02040202. Then, when reading / writing P0-25, it also reads / writes the value of P2-02 and P2-04.

P0-36	MAP2A	Target Setting of Mapping Parameter P0-26		Address: 0048H 0049H
	Operational Interface :	Panel / Software	Communication	Related Section: 4.3.5
	Default :	0x00000000		
	Control Mode :	ALL		
	Unit :	-		
	Range :	determined by the communication address of the parameter group		
	Data Size :	32-bit		
	Format :	Hexadecimal		

Settings :

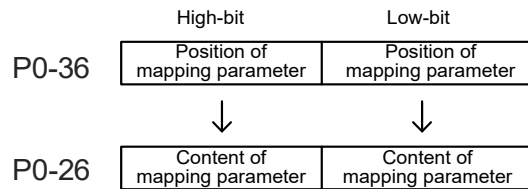

P0-37	MAP3A	Target Setting of Mapping Parameter P0-27		Address: 004AH 004BH
	Operational Interface :	Panel / Software	Communication	Related Section: 4.3.5
	Default :	0x00000000		
	Control Mode :	ALL		
	Unit :	-		
	Range :	determined by the communication address of the parameter group		
	Data Size :	32-bit		
	Format :	Hexadecimal		

Settings :

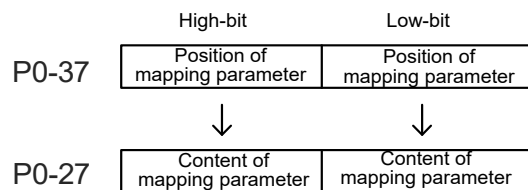

P0-38	MAP4A	Target Setting of Mapping Parameter P0-28		Address: 004CH 004DH
	Operational Interface :	Panel / Software	Communication	Related Section: 4.3.5
	Default :	0x00000000		
	Control Mode :	ALL		
	Unit :	-		
	Range :	determined by the communication address of the parameter group		
	Data Size :	32-bit		
	Format :	Hexadecimal		

Settings :

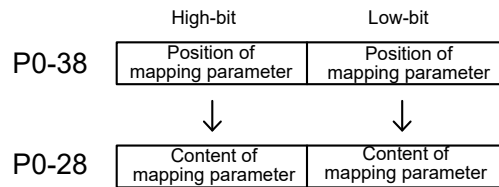

P0-39	MAP5A	Target Setting of Mapping Parameter P0-29		Address: 004EH 004FH
	Operational Interface :	Panel / Software	Communication	Related Section: 4.3.5
	Default :	0x00000000		
	Control Mode :	ALL		
	Unit :	-		
	Range :	determined by the communication address of the parameter group		
	Data Size :	32-bit		
	Format :	Hexadecimal		

Settings :

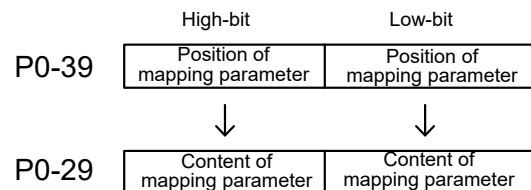

P0-40	MAP6A	Target Setting of Mapping Parameter P0-30		Address: 0050H 0051H
	Operational Interface :	Panel / Software	Communication	Related Section: 4.3.5
	Default :	0x00000000		
	Control Mode :	ALL		
	Unit :	-		
	Range :	determined by the communication address of the parameter group		
	Data Size :	32-bit		
	Format :	Hexadecimal		

Settings :

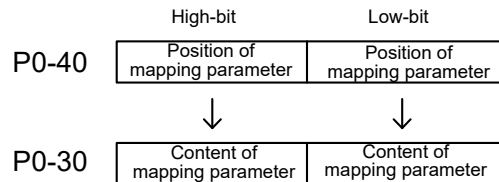

P0-41	MAP7A	Target Setting of Mapping Parameter P0-31		Address: 0052H 0053H
	Operational Interface :	Panel / Software	Communication	Related Section: 4.3.5
	Default :	0x00000000		
	Control Mode :	ALL		
	Unit :	-		
	Range :	determined by the communication address of the parameter group		
	Data Size :	32-bit		
	Format :	Hexadecimal		

Settings :

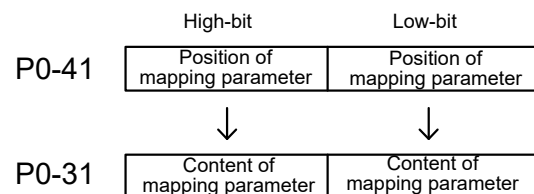

P0-42	MAP8A	Target Setting of Mapping Parameter P0-32		Address: 0054H 0055H
	Operational Interface :	Panel / Software	Communication	Related Section: 4.3.5
	Default :	0x00000000		
	Control Mode :	ALL		
	Unit :	-		
	Range :	determined by the communication address of the parameter group		
	Data Size :	32-bit		
	Format :	Hexadecimal		

Settings :

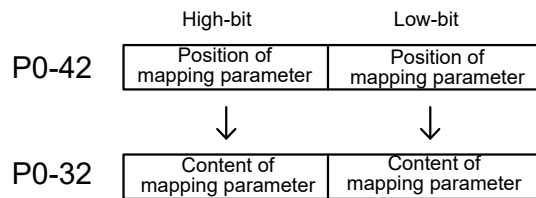

P0-43	Reserved
--------------	-----------------

P0-44★	PCMN	Status Monitor Register (for PC software)		Address: 0058H 0059H
	Operational Interface :	Panel / Software	Communication	Related Section: 4.3.5
	Default :	0		
	Control Mode :	ALL		
	Unit :	-		
	Range :	determined by the communication address of the parameter group		
	Data Size :	32-bit		
	Format :	Decimal		

Settings : Same as parameter P0-09.

P0-45 ■	PCMNA	Status Monitor Register Selection (for PC software)		Address: 005AH 005BH
	Operational Interface :	Panel / Software	Communication	Related Section: 4.3.5
	Default :	0		
	Control Mode :	ALL		
	Unit :	-		
	Range :	0~127		
	Data Size :	16-bit		
	Format :	Decimal		

Settings : Same as parameter P0-17

P0-46 ★	SVSTS	Servo Digital Output Status Display		Address: 005CH 005DH
	Operational Interface :	Panel / Software	Communication	Related Section: -
	Default :	0x0000		
	Control Mode :	ALL		
	Unit :	-		
	Range :	0x0000 ~ 0x00FF		
	Data Size :	16-bit		
	Format :	Hexadecimal		

Settings :

- Bit 0: SRDY (Servo is ready)
- Bit 1: SON (Servo ON)
- Bit 2: ZSPD (Zero speed detection)
- Bit 3: TSPD (Target speed reached)
- Bit 4: TPOS (Target position reached)
- Bit 5: TQL (Torque limiting)
- Bit 6: ALRM (Servo alarm)
- Bit 7: BRKR (Brake control output)
- Bit 8: HOME (Homing finished)
- Bit 9: OLW (Early warning for overload)
- Bit 10: WARN (When Servo warning, CW, CCW, EMGS, under voltage, Communication error, etc., occurs, DO is ON)
- Bit 11 ~ Bit 15: Reserved

P0-49	UAP	Renew Encoder Absolute Position		Address: 0062H 0063H
	Operational Interface :	Panel / Software	Communication	Related Section: N/A
	Default :	0x0000		
	Control Mode :	ALL		
	Unit :	N/A		
	Range :	0x0000~0x0002		
	Data Size :	16-bit		
	Format :	Hexadecimaldecimal		

Settings : This parameter is used to renew the absolute position data of the encoder.



Parameter Renew Setting:

- 1: Renew the encoder data to parameters P0-50 ~ P0-52 only.
- 2: Renew the parameters P0-50 ~ P0-52, and clear the position error as well. While this setting is activated, the current position of the motor will be reset as the target position of position command (same function as CCLR).

P0-50 ★	APSTS	Absolute Coordinate System Status		Address: 0064H 0065H
	Operational Interface :	Panel / Software	Communication	Related Section: N/A
	Default :	0		
	Control Mode :	ALL		
	Unit :	N/A		
	Range :	-		
	Data Size :	16-bit		
	Format :	Hexadecimal		

Settings :

Bit 7	Bit 6	Bit 5	Bit 4	Bit 3	Bit 2	Bit 1	Bit 0
Bit 15	Bit 14	Bit 13	Bit 12	Bit 11	Bit 10	Bit 9	Bit 8

Bit 0: Absolute position status
 0: Normal
 1: Absolute position is lost
 Bit 1: Voltage level of battery
 0: Normal
 1: Low battery
 Bit 2: Status of encoder multiturn
 0: Normal
 1: Overflow
 Bit 3: Status of PUU
 0: Normal
 1: Overflow
 Bit 4: Absolute coordinate system status
 0: Normal
 1: Absolute coordinate system has not been set
 Bit 5 ~ Bit 15: Reserved. Set to 0.

P0-51★	APR	Encoder Absolute Position (Multiturn)		Address: 0066H 0067H
	Operational Interface :	Panel / Software	Communication	Related Section: N/A
	Default :	0x0000		
	Control Mode :	ALL		
	Unit :	rev		
	Range :	-		
	Data Size :	16-bit		
	Format :	Decimal		

Settings : While the Bit 1 of P2-70 is set to 1 to read the encoder pulse number, this parameter represents the turns of encoder absolute position. While the Bit 1 of P2-70 is set to 0 to read the PUU number, this parameter becomes disabled and the setting value of this parameter is 0.

Display range for number of revolution: -32768 to +32767

P0-52★	APP	Encoder Absolute Position (Pulse number within Single turn or PUU)		Address: 0068H 0069H
	Operational Interface :	Panel / Software	Communication	Related Section: N/A

Default :	0x0
Control Mode :	ALL
Unit :	Pulse or PUU
Range :	-
Data Size :	32-bit
Format :	Decimal

Settings : While the Bit 1 of P2-70 is set to 1 to read the pulse number, this parameter represents the pulse number of encoder absolute position. While the Bit 1 of P2-70 is set to 0 to read the PUU number, this parameter represents the PUU number of motor absolute position.
 Display range for number of revolution:
 0 ~1280000-1 (Pulse); -2147483648 to +2147483647 (PUU)

P0-53	ZDRT	General Range Compare Digital Output – Filtering Time		Address: 006AH 006BH
	Operational Interface :	Panel / Software	Communication	Related Section: N/A
	Default :	0x0000		
	Control Mode :	ALL		
	Unit :	ms		
	Range :	0x0000 ~ 0x000F		
	Data Size :	16-bit		
	Format :	Hexadecimal		

Settings :

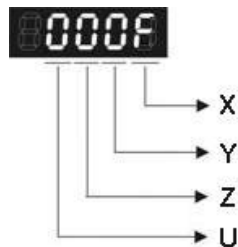

X: Filtering time for 1st monitoring variable

UYZ: Reserved

While the value of the monitoring variable is changed within the range between the setting values of P0-54 and P0-55, this parameter is used to set the filter timing for the monitoring variable. The value of monitoring variable will output after the filtering time determined by parameter P0-53.

For example: when P0-09 is used

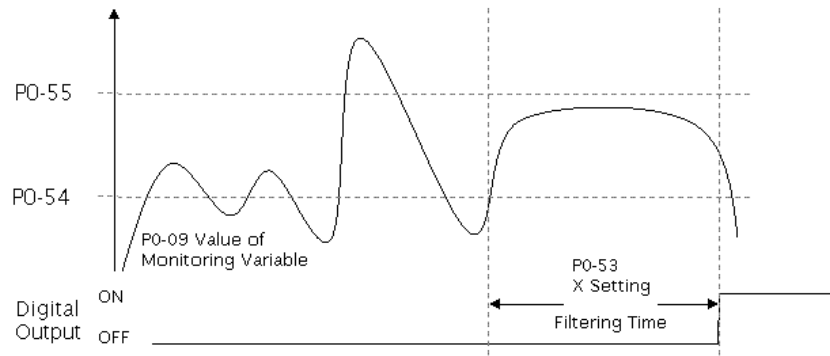

P0-54	ZON1L	General Range Compare Digital Output – Lower Limit of 1st Monitoring Variable		Address: 006CH 006DH
	Operational Interface :	Panel / Software	Communication	Related Section: N/A
	Default :	0		
	Control Mode :	ALL		
	Unit :	-		
	Range :	-2147483648 ~ +2147483647		
	Data Size :	32-bit		
	Format :	Decimal		

Settings : The value of parameter P0-09 will change within the range set in P0-54 and P0-55 and then output after the filtering time determined by parameter P0-53.X.

P0-55	ZON1H	General Range Compare Digital Output – Upper Limit of 1st Monitoring Variable	Address: 006EH 006FH
Operational Interface :		Panel / Software	Communication
Default :		0	
Control Mode :		ALL	
Unit :		-	
Range :		-2147483648 ~ +2147483647	
Data Size :		32-bit	
Format :		Decimal	

Settings : The value of parameter P0-09 will change within the range set in P0-54 and P0-55 and then output after the filtering time determined by parameter P0-53.X.

P0-56 ~ P0-62	Reserved
Reserved	

P0-63	VGT	The Time when Voltage Exceeding 400V	Address: 007EH 007FH
Operational Interface :		Panel / Software	Communication
Default :		0x0	
Control Mode :		ALL	
Unit :		ms	
Range :		-	
Data Size :		32-bit	
Format :		Decimal	

Settings : Record the accumulative time when the drive's voltage exceeding 400V.
Display range: 0x00000000 ~ 0x7FFFFFFF

P1-xx Basic Parameters

P1-00▲	PTT	The Type of External Pulse Input	Address: 0100H 0101H
	Operational Interface :	Panel / Software	Communication
	Default :	0x0002	
	Control Mode :	PT	
	Unit :	-	
	Range :	0x0000 ~ 0x1142	
	Data Size :	16-bit	
	Format :	Hexadecimal	

Related Section:
6.2.1

Settings :

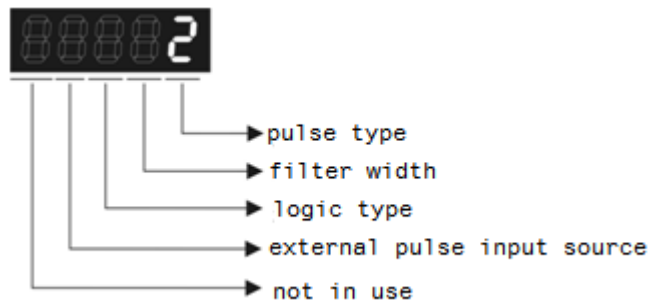

- Pulse Type
 - 0: AB phase pulse (4x)
 - 1: Clockwise (CW) and Counterclockwise (CCW) pulse
 - 2: Pulse + symbol
 - Other setting: reserved

- Filter Width

If the received frequency is much higher than the setting, it will be regarded as the noise and filtered out.

Setting Value	Min. pulse width*note1 (Low-speed filter frequency)	Setting Value	Min. pulse width*note1 (High-speed filter frequency)
0	600 ns (0.83 Mpps)	0	150 ns (3.33 Mpps)
1	2.4 us (208 Kpps)	1	600 ns (0.83 Mpps)
2	4.8 us (104 Kpps)	2	1.2 us (416 Kpps)
3	9.6 us (52 Kpps)	3	2.4 us (208 Kpps)
4	No filter function	4	No filter function

Note: When the source of external pulse is from the high-speed differential signal and the setting value is 0 (the high-speed filter frequency is 3.33 Mpps at the moment), then:

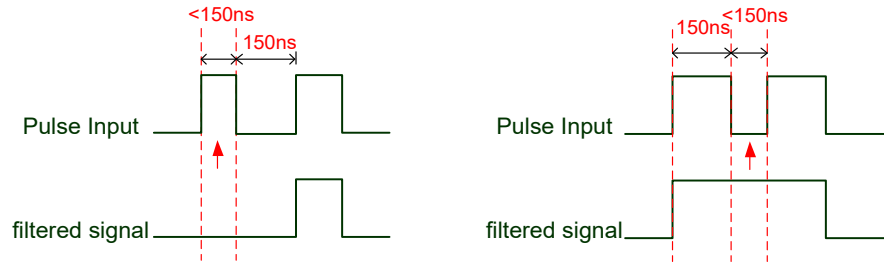

When this pulse width is shorter than 150 ns, it will be regarded as low level. Two input pulse will be seen as one.

When this pulse width is shorter than 150 ns, it will be regarded as high level. Two input pulse will be seen as one.

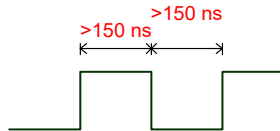

When High, Low duty of the pulse width are longer than 150 ns, it can ensure the pulse command will not be filtered.

If the user uses 2 ~ 4 MHz input pulse, it is suggested to set the filter value to 4.

Note: When the signal is the high-speed pulse specification of 4 Mpps and the settings value of the filter is 4, then the pulse will not be filtered.

● Logic Type

Logic	Pulse Type	High-speed and Low-speed Pulse Input	
		Forward	Reverse
0	AB Phase Pulse	A Pulse Phase Lead	A Pulse Phase Lag
	CW and CCW Pulse		

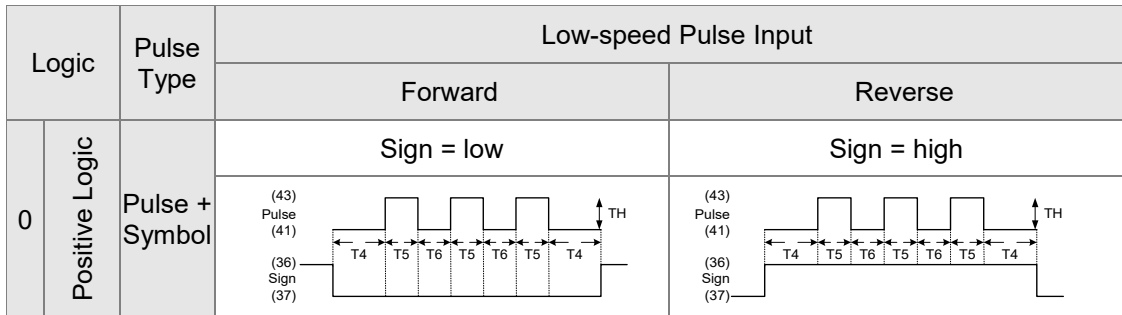
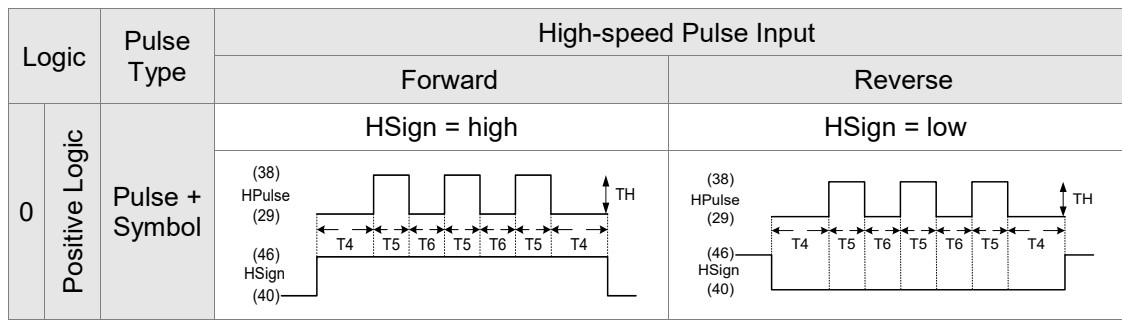

For digital circuit, it uses 0 and 1 to represent two status, which is high voltage and low voltage. In Positive Logic, 1 represents high voltage and 0 represents low voltage and vice versa in Negative Logic.

For example:

Positive Logic

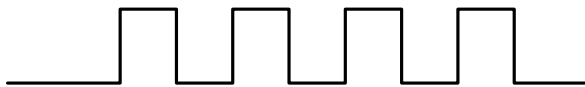

Negative Logic



Pulse Specification		Max. Input Frequency	Minimum time width					
			T1	T2	T3	T4	T5	T6
High-speed pulse	Differential Signal	4 Mpps	62.5ns	125ns	250ns	200ns	125ns	125ns
Low-speed pulse	Differential Signal	500 Kpps	0.5µs	1µs	2µs	2µs	1µs	1µs
	Open-collector	200 Kpps	1.25µs	2.5µs	5µs	5µs	2.5µs	2.5µs

Pulse Specification		Max. Input Frequency	Voltage Specification	Forward Current
High-speed pulse	Differential Signal	4 Mpps	5V	< 25 mA
Low-speed pulse	Differential Signal	500 Kpps	2.8V ~ 3.7V	< 25 mA
	Open-collector	200 Kpps	24V (Max.)	< 25 mA

- The Source of External Pulse:
 0: Low-speed optical coupler (CN1 Pin: PULSE, SIGN)
 1: High-speed differential (CN1 Pin: HPULSE, HSIGN)

P1-01●	CTL	Input Setting of Control Mode and Control Command	Address : 0102H 0103H
	Operational Interface :	Panel / Software	Communication
Default :	0x000C (for EtherCAT models) 0x000B (for DMCNET models) 0x0000 (for other models)		
Control Mode :	ALL		
Unit :			
Range :	0x0000 ~ 0x111F		
Data Size :	16-bit		
Format :	Hexadecimal		

Settings :

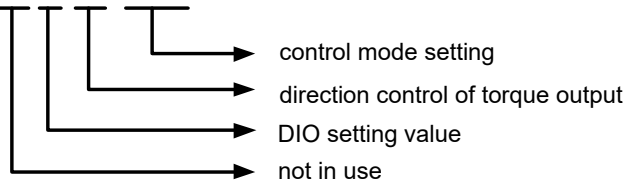
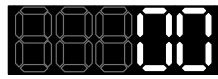

● Control Mode Settings

Mode	PT	PR	S	T	Sz	Tz
Single Mode						
00	▲					
01		▲				
02			▲			
03				▲		
04					▲	
05						▲
Dual Mode						
06	▲		▲			
07	▲			▲		
08		▲	▲			
09		▲		▲		
0A			▲	▲		
0B	CANopen Mode (work with Delta's PLC)					
	DMCNET Mode					
0C	CANopen Mode					
	EtherCAT Mode					
0D	▲	▲				
Multiple Mode						
0E	▲	▲	▲			
0F	▲	▲		▲		

- PT: Position control mode; the command source is from the external pulse and the external analog voltage.
- PR: Position control mode; the command source is from the 64 sets of internal registers which you can select with DI.POS0 – DI.POS5. Multiple homing methods are also available.
- S: Speed control mode; the command source is from the external analog voltage and the internal register which you can select with DI.SPD0 and DI.SPD1.
- T: Torque control mode; the command source is from the external analog voltage and the internal register which you can select with DI.TCM0 and DI.TCM1.
- Sz: Speed control mode; the command source is from the zero speed and the internal speed register
- Tz: Torque control mode; the command source is from the zero torque and the internal torque register
- Dual Mode: It can switch mode via the external Digital Input (DI). For example, if it is set to the dual mode of PT/S (Control mode setting: 06), the mode can be switched via DI. S-P (Please refer to table 8.1).
- Multiple Mode: It can switch mode via the external Digital Input (DI). For example, if it is set to multiple mode of PT/PR/S (Control Mode Setting: 12), the mode can be switched via DI. S-P, PT-PR (Please refer to table 8.1).

- Torque Output Direction Settings

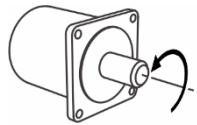
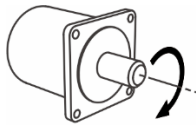
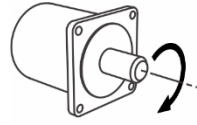
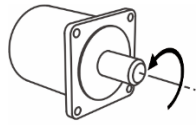
	0	1
Forward	 P(CCW)	 P(CW)
Reverse	 N(CW)	 N(CCW)

- Digital Input / Digital Output (DIO) Setting

- 0: When switching mode, DIO (P2-10 ~ P2-22) remains the original setting value and will not be changed.
- 1: When switching mode, DIO (P2-10 ~ P2-22) can be reset to the default value of each operational mode automatically.

P1-02▲	PSTL	Speed and Torque Limit Setting	Address: 0104H 0105H
	Operational Interface :	Panel / Software	Communication
	Default :	0x0000	
	Control Mode :	ALL	
	Unit :	-	
	Range :	0x0000 ~ 0x0011	
	Data Size :	16-bit	
	Format :	Hexadecimal	

Related Section:
Section 6.6
Table 8.1

Settings :

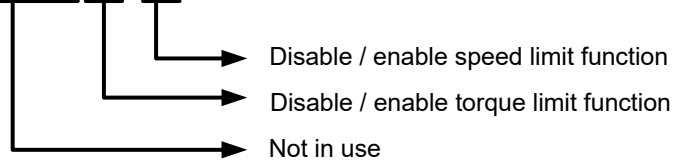
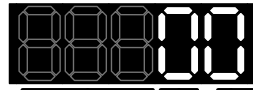

- Disable / enable speed limit function
0: Disable speed limit function
1: Enable speed limit function (it is effective in T / Tz mode only)
Others: Reserved

Block diagram of speed limit setting:

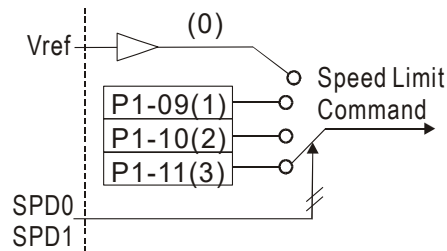

- Disable / enable torque limit function
0: Disable torque limit function
1: Enable torque limit function (it is effective in P / S / Sz mode)
Others: Reserved

Block diagram of torque limit setting:

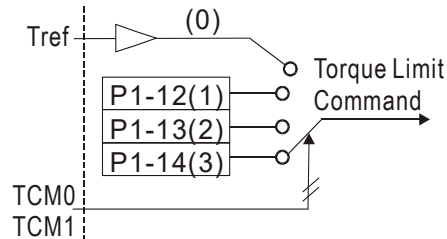

When desiring to use the torque limit function, users could use parameter to set this value to 1 and limit the torque for good. Thus, the user can save one DI setting. Also, users could enable or disable the limit function via DI.TRQLM, which is a more flexible way but would need to take one DI setting. Torque limit can be enabled by P1-02 or DI.

DI.TCM0 and DI.TCM1 are for selecting the limiting source.

P1-03	AOUT	Polarity Setting of Encoder Pulse Output		Address: 0106H 0107H
	Operational Interface :	Panel / Software	Communication	Related Section: 3.3.3
	Default :	0x0000		
	Control Mode :	ALL		
	Unit :	-		
	Range :	0x0000 ~ 0x0013		
	Data Size :	16-bit		
	Format :	Hexadecimal		

Settings :

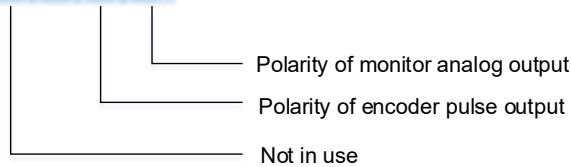

- Polarity of monitor analog output

0: MON1(+), MON2(+)	2: MON1(-), MON2(+)
1: MON1(+), MON2(-)	3: MON1(-), MON2(-)

- Polarity of encoder pulse output

0: Forward output	1: Reverse output
-------------------	-------------------

P1-04	MON1	MON1 Analog Monitor Output Proportion		Address: 0108H 0109H
	Operational Interface :	Panel / Software	Communication	Related Section: 6.4.4
	Default :	100		
	Control Mode :	ALL		

Unit :	% (full scale)
Range :	0 ~ 100
Data Size :	16-bit
Format :	Decimal

Settings : Please refer to parameter P0-03 for the setting of analog output selection.

For example:

P0-03 = 0x0 (MON1 is the speed analog output)

When the output voltage value of MON1 is V1:

Motor speed = (Max. speed × V1/8) × P1-04/100

P1-05	MON2	MON2 Analog Monitor Output Proportion		Address: 0108H 0109H
	Operational Interface :	Panel / Software	Communication	Related Section: 6.4.4
	Default :	100		
	Control Mode :	ALL		
	Unit :	% (full scale)		
	Range :	0 ~ 100		
	Data Size :	16-bit		
	Format :	Decimal		

Settings : Please refer to parameter P0-03 for the setting of analog output selection.

For example: P0-03 = 0x00 (MON2 is the speed analog output)

When the output voltage value of MON2 is V2:

Motor speed = (Max. × V2/8) × P1-05/100

P1-06	SFLT	Analog Speed Command (Low-pass Filter)		Address: 010CH 010DH
	Operational Interface :	Panel / Software	Communication	Related Section: 6.3.3
	Default :	0		
	Control Mode :	S / Sz		
	Unit :	ms		
	Range :	0 ~ 1000 (0: disable this function)		

Data Size :	16-bit
Format :	Decimal

Settings : 0: Disabled

P1-07	TFLT	Analog Torque Command (Low-pass Filter)		Address: 010EH 010FH
	Operational Interface :	Panel / Software	Communication	Related Section: 6.4.3
	Default :	0		
	Control Mode :	T / Tz		
	Unit :	ms		
	Range :	0 ~ 1000 (0: disable this function)		
	Data Size :	16-bit		
	Format :	Decimal		

Settings : 0: Disabled

P1-08	PFLT	Smooth Constant of Position Command (Low-pass Filter)		Address: 0110H 0111H
	Operational Interface :	Panel / Software	Communication	Related Section: 6.2.6
	Default :	0		
	Control Mode :	PT / PR		
	Unit :	10 ms		
	Range :	0 ~ 1000		
	Data Size :	16-bit		
	Format :	Decimal		
Example :	11 = 110 ms			

Settings : 0: Disabled

P1-09	SP1	Internal Speed Command 1 / Internal Speed Limit 1		Address: 0112H 0113H
	Operational Interface :	Panel / Software	Communication	Related Section: 6.3.1
	Default :	1000		
	Control Mode :	S / T		
	Unit :	0.1 r/min		
	Range :	-60000 ~ +60000		
	Data Size :	32-bit		
	Format :	Decimal		
	Example :	Internal speed command: 120 = 12 r/min Internal Speed Limit: Positive value and negative value is the same. Please refer to the following description.		

Settings : Internal Speed Command 1: The setting of the first internal speed command

Internal Speed Limit 1: The setting of the first internal speed limit

Example of inputting internal speed limit:

Speed limit setting value of P1-09	Allowable Speed Range	Forward Speed Limit	Reverse Speed Limit
1000	-100 ~ 100 r/min	100 r/min	-100 r/min
-1000			

P1-10	SP2	Internal Speed Command 2 / Internal Speed Limit 2		Address: 0114H 0115H
	Operational Interface :	Panel / Software	Communication	Related Section: 6.3.1
	Default :	2000		
	Control Mode :	S / T		
	Unit :	0.1 r/min		
	Range :	-60000 ~ +60000		
	Data Size :	32-bit		
	Format :	Decimal		

Example : Internal speed command:
120 = 12 r/min
Internal Speed limit: Positive value and negative value is the same. Please refer to the following description.

Settings : Internal Speed Command 2: The setting of the 2nd internal speed command

Internal Speed Limit 2: The setting of the second internal speed limit

Example of inputting internal speed limit:

Speed limit setting value of P1-10	Allowable Speed Range	Forward Speed Limit	Reverse Speed Limit
1000	-100 ~ 100 r/min	100 r/min	-100 r/min
-1000			

P1-11	SP3	Internal Speed Command 3 / Internal Speed Limit 3		Address: 0116H 0117H
	Operational Interface :	Panel / Software	Communication	Related Section: 6.3.1
	Default :	3000		
	Control Mode :	S / T		
	Unit :	0.1 r/min		
	Range :	-60000 ~ +60000		
	Data Size :	32-bit		
	Format :	Decimal		
	Example :	Internal Speed Command: 120 = 12 r/min Internal Speed limit: Positive value and negative value is the same. Please refer to the following description.		

Settings : Internal Speed Command 3: The setting of the third internal speed command

Internal Speed Limit 3: The setting of the third internal speed limit

Example of inputting internal speed limit:

Speed limit setting of P1-11	Allowable Speed Range	Forward Speed Limit	Reverse Speed Limit
1000	-100 ~ 100 r/min	100 r/min	-100 r/min
-1000			

P1-12	TQ1	Internal Torque Command 1 / Internal Torque Limit 1		Address: 0118H 0119H
	Operational Interface :	Panel / Software	Communication	Related Section: 6.4.1
	Default :	100		
	Control Mode :	T / P, S		
	Unit :	%		
	Range :	-380 ~ +380 *1		
	Data Size :	16-bit		
	Format :	Decimal		
	Example :	Internal Torque Command: 30 = 30% Internal Torque Limit: Positive value and negative value is the same. Please refer to the following description.		

Settings : Internal Torque Command 1: The setting of the first internal torque command

Internal Torque Limit 1: The setting of the first internal torque limit

Example of inputting internal torque limit:

Torque limit setting value of P1-12	Allowable Torque Range	Forward Torque Limit	Reverse Torque Limit
30	-30 ~ 30%	30%	-30%
-30			

Note: please refer to the motor specification for the actual motor torque. If the actual maximum motor torque is 300%, the actual torque output will be 300% even when this parameter is set to 380%.

P1-13	TQ2	Internal Torque Command 2 / Internal Torque Limit 2		Address: 011AH 011BH
	Operational Interface :	Panel / Software	Communication	Related Section: 6.4.1
	Default :	100		
	Control Mode :	T / P, S		
	Unit :	%		
	Range :	-380 ~ +380 *1		
	Data Size :	16-bit		

Format :	Decimal
Example :	Internal Torque Command: 30 = 30% Internal Torque Limit: Positive value and negative value is the same. Please refer to the following description.

Settings : Internal Torque Command 2: The setting of the second internal torque command

Internal Torque Limit 2: The setting of the second internal torque limit

Example of inputting internal torque limit:

Torque limit setting value of P1-13	Allowable Torque Range	Forward Torque Limit	Reverse Torque Limit
30	-30 ~ 30%	30%	-30%
-30			

Note: please refer to the motor specification for the actual motor torque. If the actual maximum motor torque is 300%, the actual torque output will be 300% even when this parameter is set to 380%.

P1-14	TQ3	Internal Torque Command 3 / Internal Torque Limit 3		Address: 011CH 011DH
	Operational Interface :	Panel / Software	Communication	Related Section: 6.4.1
	Default :	100		
	Control Mode :	T / P, S		
	Unit :	%		
	Range :	-380 ~ +380 *1		
	Data Size :	16-bit		
	Format :	Decimal		
	Example :	Internal Torque Command: 30 = 30% Internal Torque Limit: Positive value and negative value is the same. Please refer to the following description.		

Settings : Internal Torque Command 3: The setting of the third internal torque command

Internal Torque Limit 3: The setting of the third internal torque limit

Example of inputting internal torque limit:

Torque limit setting value of P1-14	Allowable Torque Range	Forward Torque Limit	Reverse Torque Limit
30	-30 ~ 30%	30%	-30%
-30			

Note: please refer to the motor specification for the actual motor torque. If the actual maximum motor torque is 300%, the actual torque output will be 300% even when this parameter is set to 380%.

P1-15	CXFT	Capture Synchronous Axis – Threshold of Correction		Address: 011EH 011FH
	Operational Interface :	Panel / Software	Communication	Related Section:
	Default :	0x0000		
	Control Mode :	ALL		
	Unit :	-		
	Range :	0x0000 ~ 0x1F5F		
	Data Size :	16-bit		
	Format :	Hexadecimal		

Settings :

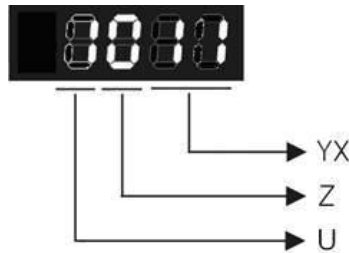

YX: Threshold of correction (%)

Z: Filter intensity

U: Filter is functioning (read-only)

(It will be provided after the version of V1.0.38 sub15)

YX: When synchronous axis captures the signal, the system will calculate the error. This function is enabled only when the error is less than the setting range. Otherwise, the system will use the new threshold of correction to perform the operation.

YX	00	01 ~ 05F
Function	Disabled	It will be enabled when error is between 1% and YX%.

Z	0	1 ~ F
Function	Disabled	Average of 2 ^Z : Enabled

Z: The setting of filter intensity (Bigger value brings less severe change and better filter effect)

U: Value Definition (read-only):

0: Filter function is disabled. It means the error is greater than Y & X Range.

1: Filter function is enabled. It means the error is within Y & X range.

If value Z or YX is 0, filter function is disabled.

P1-16	CSOF	Capture Synchronous Axis – Offset Compensation		Address: 0120H 0121H
	Operational Interface :	Panel / Software	Communication	Related Section:
	Default :	0		
	Control Mode :	PR		
	Unit :	Pulse unit of Capture Axis		
	Range :	-32768 ~ +32767		
	Data Size :	16-bit		
	Format :	Decimal		

Settings : When capture synchronous axis is enabled, if desire to change the synchronous error (P5-79), setting this parameter will do.

Write P1-16: P5-79 = P5-79 + writing value

Read P1-16: Read value = P5-79

Note: 1) The setting value of this parameter is the accumulative value, which will not be influenced by current error value.

2) The value of P5-79 can be monitored by monitoring variable 0x54.

P1-17	TEET	Compensation of Following Error - Additional Time Setting		Address: 0122H 0123H
	Operational Interface :	Panel / Software	Communication	Related Section:
	Default :	0		
	Control Mode :	ALL		
	Unit :	ms; the smallest unit is usec		
	Range :	-20.000 ~ +20.000 (three decimal places)		
	Data Size :	16-bit		
	Format :	Decimal		
	Example :	1.5 = Motor speed x 1.5 ms (PUU)		

Settings : When this function is enabled (P1-36 = 1), the system will make the position error (PUU) close to 0 according to the compensation amount of command. If the time delay is caused by other reasons, users could setup the additional compensation time to compensate the position error. (This function is available in firmware version V1.038 sub15 and later models only.)

Additional compensation distance = P1-17 x Motor speed

- Note: 1) The position error is proportioned to the speed.
2) Value of P1-36 has to set to 1.

P1-18	CPCT	Electronic Cam (E-Cam) Pulse Phase Compensation – Time Setting		Address: 0124H 0125H
	Operational Interface :	Panel / Software	Communication	Related Section:
	Default :	0		
	Control Mode :	PR		
	Unit :	ms with fraction down to usec		
	Range :	-20.000 ~ +20.000 (Three decimal places)		
	Data Size :	16-bit		
	Format :	Decimal		

Settings : (This function is available in firmware version V1.038 sub48 and later models only)

This parameter is used to compensate the delay pulse phase when the electronic cam function is enabled during operation. Please use this

parameter with P1-21.

$$\text{Compensated Pulse Phase (pls)} = \text{P1-18} \times (\text{Pulse Frequency of E-Cam Master Axis (Kpps)} - \text{P1-21})$$

Note:

1. The setting value of this parameter is proportioned to the value of the pulse frequency of E-Cam master axis.
2. The pulse phase compensation function is enabled only when the setting value of parameter P1-18 is not equal to 0.
3. The pulse phase compensation function is enabled only when the value of the pulse frequency of E-Cam master axis (monitoring variable is 060) Pulse number of E-Cam master axis (Incremental)) is higher than the setting value of parameter P1-21.

P1-19	CPEX	CAPTURE / COMPARE – Additional Function Settings		Address: 0126H 0127H
	Operational Interface :	Panel / Software	Communication	Related Section: N/A
	Default :	0		
	Control Mode :	ALL		
	Unit :	-		
	Range :	0x0000 ~ 0x0103		
	Data Size :	16-bit		
	Format :	Hexadecimal		

Settings :

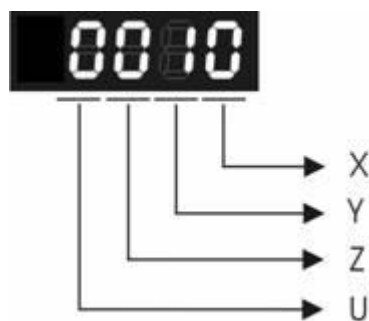

X: Bit settings of Capture additional function settings:

Bit	3	2	1	0
Function	-	-	-	Cycle Mode
Explanation	-	-	-	Enable the cycle mode. After the last position is captured, the system will automatically repeat executing this CAPTURE function. The captured data is still stored in the data array that the starting address is specified by P5-36. (This function is available in firmware

				version V1.038 sub19 and later models only)
--	--	--	--	---

Y: Reserved

Z: Bit settings of Compare additional function settings:

Bit	3	2	1	0
Function	-	-	-	Automatically set P1-24 to 0.
Explanation	-	-	-	When Bit0 is set to 1, P1-24 will only be effective once and reset to 0 automatically. Otherwise, the value of P1-24 will remain unchanged. (This function is available in firmware version V1.038 sub19 and later models only)

U: Reserved

P1-20	CPMK	CAPTURE – Masking Range Setting		Address: 0128H 0129H
	Operational Interface :	Panel / Software	Communication	Related Section: N/A
	Default :	0		
	Control Mode :	ALL		
	Unit :	The Pulse Unit of Capture Axis		
	Range :	0 ~ +100000000		
	Data Size :	32-bit		
	Format :	Decimal		

Settings : When multiple points are required to be captured, after each point is captured, the masking range can be set in this parameter. In the masking area, the CAPTURE function will not work. The masking range is defined as follows:

$$(CAP_DATA-P1-20 \sim CAP_DATA+P1-20)$$

Note:

When the setting value of this parameter is set to 0, the masking function is disabled.

P1-21	CPCL	E-Cam Pulse Phase Compensation – Min. Frequency Setting of Master Axis	Address: 012AH 012BH
Operational Interface :	Panel / Software	Communication	Related Section: N/A
Default :	0		
Control Mode :	PR		
Unit :	Kpps (Kpulse/sec)		
Range :	0 ~ 30000		
Data Size :	16-bit		
Format :	Decimal		

Settings : (This function is available in firmware version V1.038 sub48 and later models only)

This parameter is used to compensate the delay pulse phase when the electronic cam function is enabled during operation. Please use this parameter with P1-18.

Compensated Pulse Phase (pls) = P1-18 x (Pulse Frequency of E-Cam Master Axis (Kpps) – P1-21)

Note:

1. The setting value of this parameter is proportioned to the value of the pulse frequency of E-Cam master axis.
2. The pulse phase compensation function is enabled only when the setting value of parameter P1-18 is not equal to 0.
3. The pulse phase compensation function is enabled only when the value of the pulse frequency of E-Cam master axis (monitoring variable is 060) is higher than the setting value of parameter P1-21.

P1-22	SPF1	PR Special Filter Settings	Address: 012CH 012DH
	Operational Interface :	Panel / Software Communication	Related Section:
	Default :	0x0000	
	Control Mode :	PR	
	Unit :	-	
	Range :	0x0000 ~ 0x107F	
	Data Size :	16-bit (format = UZYX)	
	Format :	Hexadecimal	

Settings : YX: Acceleration time limit (0: Disabled, [1~127] x 10 ms). Units: 10 ms

Z: Reserved

U: Reverse inhibit (0: Disabled; 1: Enabled)

YX: The acceleration time limit is 0 ~ 1270 ms. When the changes of PR (or E-Cam) commands are too fast, it will cause the vibration of the mechanical system and affect the system performance. This function can be used to control the acceleration (deceleration) speed without exceeding the limit and can smooth the operation, reduce the noise and extend the system life.

This function is different from the general filter. The traditional one filter the command regardless the command change. This causes the delay of command delivered and reduces the efficiency of the system. This function can help to disable the filter function when the command changes within the limit. Then, the commands can be delivered without any time delay. The definition of this setting is the required acceleration time when the motor runs from 0 to 3000 r/min. The required time is longer, the effect of the filter function is better and the acceleration / deceleration will become smoother.

Note:

The unit of acceleration time limit is 10 ms. For example, if YX=12h, the acceleration time limit is 180 ms. It means the filter function is enabled when the acceleration or deceleration time is faster than 180 ms. Otherwise, the command will remain unchanged.

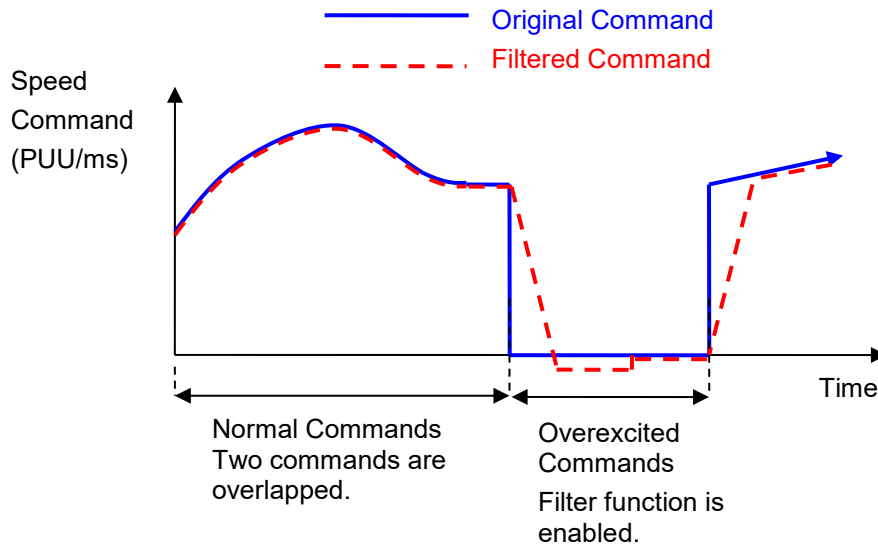

Note: When this filter function is enabled, it may cause the motor goes beyond the original position. Usually, the motor will return to the original position after the command becomes stable. However, if the command does not become stable, the internal position errors may be accumulated and result in AL404.

Note: The filter time has to be set properly. It should be shorter than the acceleration time and longer than the abnormal command.

Note: The function of U item can be used to avoid the reverse operation.

U: Reverse Inhibit Function (0: Disable the function; 1: enable the function)

When this reverse inhibit function is enabled, the reverse command will be inhibited. The reverse command will be reserved and output after the received forward command exceeds the reserved reverse command.

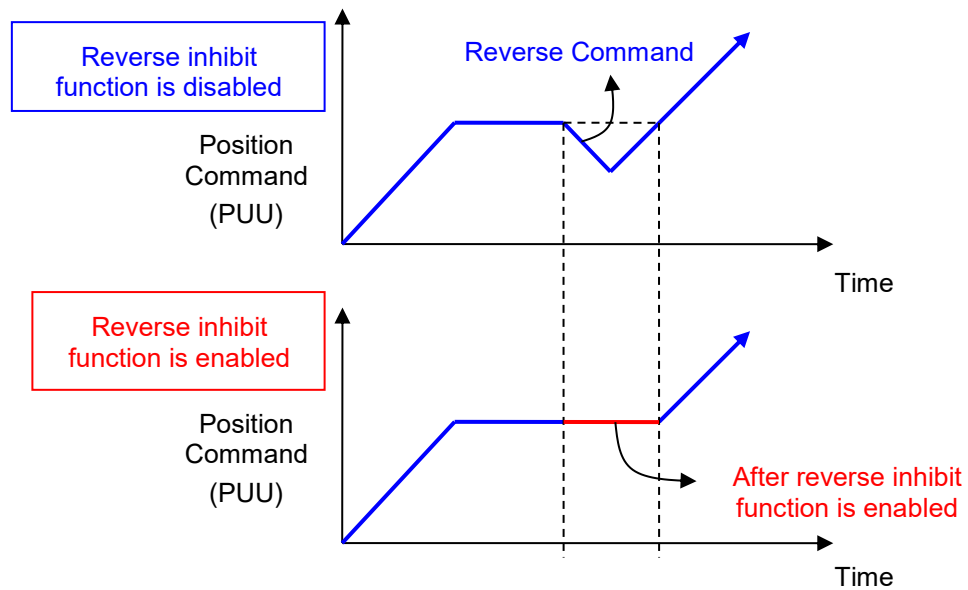

P1-23	CMOF	COMPARE - Offset Data of CMP (non-volatile)		Address: 012EH 012FH
	Operational Interface :	Panel / Software	Communication	Related Section :
	Default :	0		
	Control Mode :	ALL		
	Unit :	Pulse unit of compare source		
	Range :	-10000000 ~ +10000000		
	Data Size :	32-bit		
	Format :	Decimal		

Settings : The real compared data is offset by this value.

$$\text{CMP_DATA} = \text{DATA_ARRAY[*]} + \text{P1-23} + \text{P1-24}$$

- Note: 1) P1-23: Non-volatile parameter
 2) P1-24: After setting, if P1-19.Z0 = 1, the value will be 0 automatically.
 3) CMP_DATA can be monitored via monitoring variable V25h(037).

P1-24	CMOF	COMPARE - Offset Data of CMP (can reset to 0 automatically)		Address: 0130H 0131H
	Operational Interface :	Panel / Software	Communication	Related Section:
	Default :	0		
	Control Mode :	ALL		
	Unit :	Pulse unit of compare source		
	Range :	-32768 ~ +32767		
	Data Size :	16-bit		
	Format :	Decimal		

Settings : The real compared data is offset by this value.
 $\text{CMP_DATA} = \text{DATA_ARRAY[*]} + \text{P1-23} + \text{P1-24}$

Note: 1) P1-24: volatile parameter.

2) After setting, if P1-19.Z0 = 1, the value will be 0 automatically.

3) CMP_DATA can be monitored via monitoring variable V25h(037).

P1-25	VSF1	Low-frequency Vibration Suppression (1)		Address: 0132H 0133H
Operational Interface :	Panel / Software	Communication		Related Section: 6.2.9
Default :	1000			
Control Mode :	PT / PR			
Unit :	0.1 Hz			
Range :	10 ~ 1000			
Data Size :	16-bit			
Format :	Decimal			
Example :	150 = 15 Hz			

Settings : The setting value of the first low-frequency vibration suppression. If P1-26 is set to 0, then it will disable the first low-frequency filter.

P1-26	VSG1	Low-frequency Vibration Suppression Gain (1)		Address: 0134H 0135H
Operational Interface :	Panel / Software	Communication		Related Section: 6.2.9
Default :	0			
Control Mode :	PT / PR			
Unit :	-			
Range :	0 ~ 9 (0: Disable the first low-frequency filter)			
Data Size :	16-bit			
Format :	Decimal			

Settings : The first low-frequency vibration suppression gain. The bigger value it is, the better the position response will be. However, if the value is set too big, the motor will not be able to smoothly operate. It is suggested to set the value to 1.

P1-27	VSF2	Low-frequency Vibration Suppression (2)		Address: 0136H 0137H
	Operational Interface :	Panel / Software	Communication	Related Section: 6.2.9
	Default :	1000		
	Control Mode :	PT / PR		
	Unit :	0.1 Hz		
	Range :	10 ~ 1000		
	Data Size :	16-bit		
	Format :	Decimal		
	Example :	150 = 15 Hz		

Settings : The setting value of the second low-frequency vibration suppression. If P1-28 is set to 0, then it will disable the second low-frequency filter.

P1-28	VSG2	Low-frequency Vibration Suppression Gain (2)		Address: 0138H 0139H
	Operational Interface :	Panel / Software	Communication	Related Section: 6.2.9
	Default :	0		
	Control Mode :	PT / PR		
	Unit :	-		
	Range :	0 ~ 9 (0: Disable the second low-frequency filter)		
	Data Size :	16-bit		
	Format :	Decimal		

Settings : The second low-frequency vibration suppression gain. The bigger value it is, the better the position response will be. However, if the value is set too big, the motor will not be able to smoothly operate. It is suggested to set the value to 1.

P1-29	AVSM	Auto Low-frequency Vibration Supression Setting	Address: 013AH 013BH
Operational Interface :	Panel / Software	Communication	Related Section: 6.2.9
Default :	0		
Control Mode :	PT / PR		
Unit :	-		
Range :	0 ~ 1		
Data Size :	16-bit		
Format :	DEC		

Settings : 0: The function is disabled.
1: The value resets to 0 after vibration suppression.

Description of Auto Mode Setting:

When the parameter is set to 1, it is in auto suppression. When the vibration frequency is not being detected or the value of searched frequency is stable, the parameter will set to 0 and save the low-frequency vibration suppression to P1-25 automatically.

P1-30	VCL	Low-frequency Vibration Detection	Address: 013CH 013DH
Operational Interface :	Panel / Software	Communication	Related Section: 6.2.9
Default :	500		
Control Mode :	PT / PR		
Unit :	Pulse		
Range :	1 ~ 8000		
Data Size :	16-bit		
Format :	Decimal		

Settings : When enabling the auto suppression (P1-29 = 1), it will automatically search the detection level. The lower the value is, the more sensitive the detection will be. However, it is easy to misjudge the noise or regard the other low-frequency vibration as the suppression frequency. If the value is bigger, it will make more precise judgment. However, if the vibration of the mechanism is smaller, it might not detect the frequency of low-frequency vibration.

P1-31	Reserved		
--------------	-----------------	--	--

P1-32	LSTP	Motor Stop Mode	Address: 0140H 0141H
--------------	-------------	------------------------	---------------------------------

Operational Interface :	Panel / Software	Communication	Related Section: -
Default :	0		
Control Mode :	ALL		
Unit :	-		
Range :	0 ~ 0x20		
Data Size :	16-bit		
Format :	Hexadecimal		

Settings :

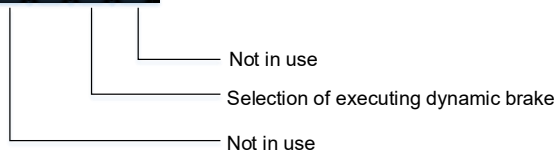

Selection of executing dynamic brake: Stop Mode when Servo Off or Alarm (including EMGS) occurs.

0: Execute dynamic brake

1: Motor free run

2: Execute dynamic brake first, then execute free run until it stops (The motor speed is slower than P1-38).

When PL and NL occur, please refer to event time setting value of P5-03 for determining the deceleration time. If the setting is 1 ms, the motor can stop instantaneously.

P1-33	Reserved		
--------------	-----------------	--	--

P1-34	TACC	Acceleration Constant of S-Curve	Address: 0144H 0145H
--------------	-------------	---	---------------------------------

Operational Interface :	Panel / Software	Communication	Related Section: 6.3.3
Default :	200		
Control Mode :	S		

Unit :	ms
Range :	1 ~ 65500
Data Size :	16-bit
Format :	Decimal

Settings : Acceleration Constant of Speed:
P1-34, P1-35 and P1-36, the acceleration time of speed command from zero to the rated speed, all can be set individually. Even when P1-36 is set to 0, it still has acceleration / deceleration of trapezoid-curve.

- Note: 1) When the source of speed command is analog, and P1-36 is set to 0, it will disable S-curve function.
2) When the source of speed command is analog, the max. range of P1-34 will be set within 20000 automatically.

P1-35	TDEC	Deceleration Constant of S-Curve		Address: 0146H 0147H
	Operational Interface :	Panel / Software	Communication	
Default :	200			
Control Mode :	S			
Unit :	ms			
Range :	1 ~ 65500			
Data Size :	16-bit			
Format :	Decimal			

Settings : Deceleration Constant of Speed:
P1-34, P1-35 and P1-36, the deceleration time of speed command from the rated speed to zero, all can be set individually. Even when P1-36 is set to 0, it still has acceleration / deceleration of trapezoid-curve.

- Note: 1) When the source of speed command is analog, and P1-36 is set to 0, it will disable S-curve function.
2) When the source of speed command is analog, the max. range of P1-35 will be set within 20000 automatically.

P1-36	TSL	Acceleration / Deceleration Constant of S-Curve		Address: 0148H 0149H
	Operational Interface :	Panel / Software	Communication	Related Section: 6.3.3
	Default :	0		
	Control Mode :	S, PR		
	Unit :	ms		
	Range :	0 ~ 65500 (0: disable this function)		
	Data Size :	16-bit		
	Format :	Decimal		

Settings : Acceleration / Deceleration Constant of S-Curve:
Speed

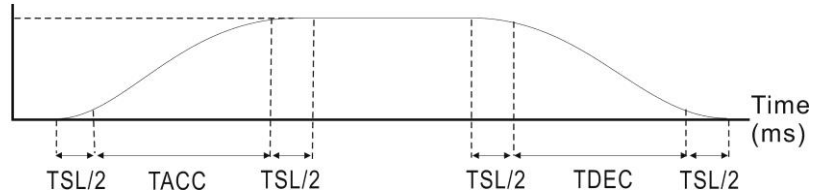

P1-34: Set the acceleration time of acceleration / deceleration of trapezoid-curve

P1-35: Set the deceleration time of acceleration / deceleration of trapezoid-curve

P1-36: Set the smoothing time of S-curve acceleration and deceleration

P1-34, P1-35, and P1-36 can be set individually. Even when P1-36 is set to 0, it still has acceleration / deceleration of trapezoid-curve.

Version after V1.036 sub00 provides the compensation function of following error.

	P1-36 = 0	P1-36 = 1	P1-36 > 1
Smoothing function of S-curve	Disable	Disable	Enable
Compensation function of following error	Disable	Enable	Determined by P2-68.X

- Note:
- 1) When the source of speed command is analog, and P1-36 is set to 0, it will disable S-curve function.
 - 2) When the source of speed command is analog, the max. range of P1-36 will be set within 10000 automatically.

P1-37	GDR	Inertia Ratio and Load Weight Ratio to Servo Motor		Address: 014AH 014BH
	Operational Interface :	Panel / Software	Communication	
Default :	1.0	10		
Control Mode :	ALL			
Unit :	1 times	0.1 times		
Range :	0.0 ~ 200.0	0 ~ 2000		
Data Size :	16-bit			
Format :	One decimal	DEC		
Example :	1.5 = 1.5 times	15 = 1.5 times		
Settings :	Inertia ratio to servo motor (rotary motor): (J_load / J_motor) Among them: J_motor: Rotor inertia of the servo motor J_load: Total equivalent of inertia of external mechanical load.			

P1-38	ZSPD	Zero Speed Range Setting		Address: 014CH 014DH
	Operational Interface :	Panel / Software	Communication	
Default :	10.0	100		
Control Mode :	ALL			
Unit :	1 r/min	0.1 r/min		
Range :	0.0 ~ 200.0	0 ~ 2000		
Data Size :	16-bit			
Format :	One decimal	DEC		
Example :	1.5 = 1.5 r/min	15 = 1.5 r/min		
Settings :	Setting the output range of zero-speed signal (ZSPD). When the forward / reverse speed of the motor is slower than the setting value, the digital output will be enabled.			

P1-39	SSPD	Target Motor Detection Level		Address: 014EH 014FH
	Operational Interface :	Panel / Software	Communication	Related Section: Table 8.2
	Default :	3000		
	Control Mode :	ALL		
	Unit :	r/min		
	Range :	0 ~ 5000		
	Data Size :	16-bit		
	Format :	Decimal		

Settings : When the target speed is reached, DO (TSPD) is enabled. It means when the motor speed in forward / reverse direction is higher than the setting value, the target speed is reached and enables DO.

P1-40	VCM	Maximum Output of Analog Speed Command		Address: 0150H 0151H
	Operational Interface :	Panel / Software	Communication	Related Section: 6.3.4
	Default :	Same as the rated speed of each model		
	Control Mode :	S / T		
	Unit :	r/min		
	Range :	0 ~ 5000		
	Data Size :	32-bit		
	Format :	Decimal		

Settings : Maximum Speed of Analog Speed Command:
 In speed mode, the analog speed command inputs the swing speed setting of the max. voltage (10V).
 For example, if the setting is 3000, when the external voltage input is 10V, it means the speed control command is 3000 r/min. If the external voltage input is 5V, then the speed control command is 1500r/min.
 $\text{Speed control command} = \text{input voltage value} \times \text{setting value} / 10$
 In torque mode, analog speed limit inputs the swing speed limit setting of the max. voltage (10V).
 $\text{Speed limit command} = \text{input voltage value} \times \text{setting value} / 10$

P1-41 ▲	TCM	Maximum Output of Analog Torque Speed		Address: 0152H 0153H
Operational Interface :	Panel / Software	Communication		Related Section: 6.4.4
Default :	100			
Control Mode :	ALL			
Unit :	%			
Range :	0 ~ 1000			
Data Size :	16-bit			
Format :	Decimal			

Settings : Maximum Output of Analog Torque Speed:

In torque mode, the analog torque command inputs the torque setting of the max. voltage (10V). When the default setting is 100, if the external voltage inputs 10V, it means the torque control command is 100% rated torque. If the external voltage inputs 5V, then the torque control command is 50% rated torque.

Torque control command = input voltage value x setting value/10 (%)

In speed, PT, and PR modes, the analog torque limit inputs the torque limit setting of the max. voltage (10V).

Torque limit command = input voltage value x setting value/10 (%)

P1-42	MBT1	Enable Delay Time of Brake		Address: 0154H 0155H
Operational Interface :	Panel / Software	Communication		Related Section: 6.5.5
Default :	0			
Control Mode :	ALL			
Unit :	ms			
Range :	0 ~ 1000			
Data Size :	16-bit			
Format :	Decimal			

Settings : Set the delay time from servo ON to activate the signal of mechanical brake (BRKR).

P1-43	MBT2	Disable Delay Time of Brake	Address: 0156H 0157H
	Operational Interface :	Panel / Software	Communication
	Default :	0	
	Control Mode :	ALL	
	Unit :	ms	
	Range :	-1000 ~ 1000	
	Data Size :	16-bit	
	Format :	Decimal	

Related Section: 6.5.5

Settings : Set the delay time from servo OFF to switch off the signal of brake (BRKR).

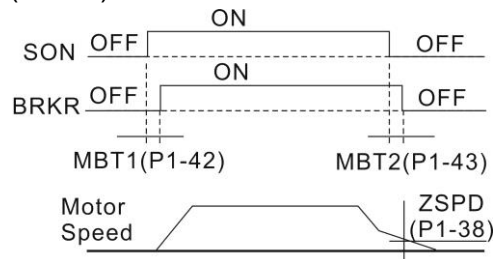

- Note:
- 1) If the delay time of P1-43 has not finished yet and the motor speed is slower than P1-38, the signal of brake (BRKR) will be disabled.
 - 2) If the delay time of P1-43 is up and the motor speed is higher than P1-38, the signal of brake (BRKR) will be disabled.
 - 3) When Servo OFF due to Alarm (except AL022) or emergency, the setting of P1-43 is equivalent to 0 if P1-43 is set to a negative value.

P1-44 ▲	GR1	Gear Ratio (Numerator) (N1)	Address: 0158H 0159H
	Operational Interface :	Panel / Software	Communication
	Default :	128	
	Control Mode :	PT / PR	
	Unit :	Pulse	
	Range :	1 ~ (2 ²⁹ -1)	
	Data Size :	32-bit	
	Format :	Decimal	

Related Section: 6.2.5

Settings : Please refer to P2-60 ~ P2-62 for the setting of multiple gear ratio (numerator).

- Note:
- 1) In PT mode, the setting value can be changed when Servo ON.
 - 2) In PR mode, the setting value can be changed when Servo OFF.
 - 3) In communication mode (DMCNET / CANopen / EtherCAT), if you cycle the power to the drive, the E-Gear ratio is set to the default value of the communication protocol. Resetting to the default value results in the reconstruction of the absolute coordinate system, so you must re-do the homing procedure. If you do not want the absolute coordinates to be reset to the default value, please set P3-12.Z to 1. For details, please refer to P3-12.

P1-45	GR2	Gear Ratio (Denominator) (M)	Address: 015AH 015BH
	Operational Interface :	Panel / Software	Communication
	Default :	10	
	Control Mode :	PT / PR	
	Unit :	Pulse	
	Range :	1 ~ (2 ³¹ -1)	
	Data Size :	32-bit	
	Format :	Decimal	

Related Section:
6.2.5

Settings : If the setting is wrong, the servo motor will easily have sudden unintended acceleration.

Please follow the rules for setting:

The setting of pulse input:

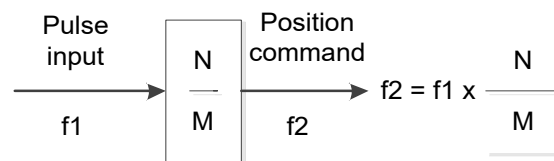

Range of command pulse input: $1 / 50 < N_x / M < 25600$

- Note:
- 1) The setting value cannot be changed when Servo ON neither in PT nor in PR mode.
 - 2) In communication mode (DMCNET / CANopen / EtherCAT), if you cycle the power to the drive, the E-Gear ratio is set to the default value of the communication protocol. Resetting to the default value results in the reconstruction of the absolute coordinate system, so you must re-do the homing procedure. If you do not want the absolute coordinates to be reset to the default value, please set P3-12.Z to 1. For details, please refer to P3-12.

P1-46 ▲	GR3	Pulse Number of Encoder Output		Address: 015CH 015DH
	Operational Interface :	Panel / Software	Communication	Related Section: -
	Default :	2500		
	Control Mode :	ALL		
	Unit :	Pulse		
	Range :	20 ~ 320000		
	Data Size :	32-bit		
	Format :	Decimal		
Settings :	<p>The number of single-phase pulse output per revolution. Setting range: 20 – 320000 The maximum output frequency of the hardware is 19.8 MHz.</p> <p>Note: The following circumstances might exceed the max. allowable input pulse frequency and occurs AL018:</p> <ol style="list-style-type: none"> 1. Abnormal encoder 2. The motor speed is faster than the setting of P1-76. 3. $\frac{\text{Motor Speed}}{60} \times P1-46 \times 4 > 19.8 \times 10^6$ 			

P1-47	SPOK	Speed Reached (DO : SP_OK) Range		Address: 015EH 015FH
	Operational Interface :	Panel / Software	Communication	Related Section: -
	Default :	10		
	Control Mode :	S / Sz		
	Unit :	rpm		
	Range :	0 ~ 300		
	Data Size :	16-bit		
	Format :	Decimal		
Settings :	<p>When the deviation between speed command and motor feedback speed is smaller than this parameter, then the digital output DO.SP_OK (DO code is 0x19) is ON.</p>			

Block diagram:

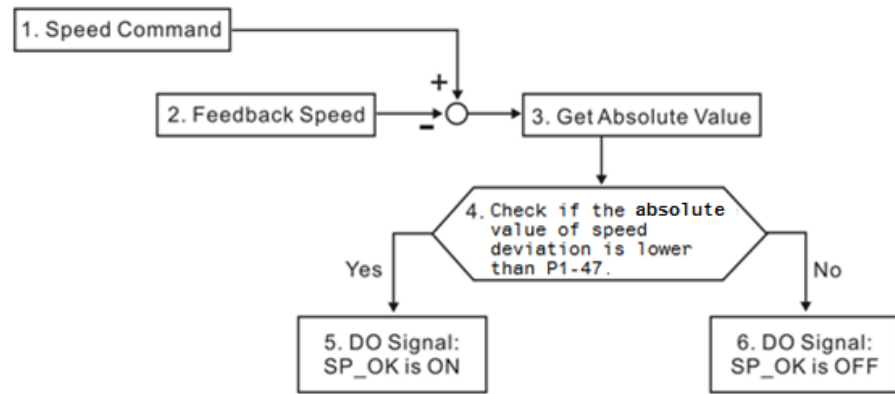

1. Speed command: It is the command issued by the user (without acceleration / deceleration), not the one of front end speed circuit.
Source: Analog voltage and register
2. Feedback speed: The actual speed of the motor and have gone through the filter.
3. Obtain the absolute value.
4. DO.SP_OK will be ON when the absolute value of speed error is smaller than P1-47, or it will be OFF. If P1-47 is 0, DO.SP_OK is always OFF.

P1-48	MCOK	Operation Selection of Motion Reached (DO.MC_OK)	Address: 0160H 0161H
Operational Interface :	Panel / Software	Communication	Related Section: -
Default :	0x0000		
Control Mode :	PR		
Unit :	-		
Range :	0x0000 ~ 0x0011		
Data Size :	16-bit		
Format :	Hexadecimal		

Settings : Control selection of digital output DO.MC_OK (DO code is 0x17).
(It will be available after firmware version V1.003 sub08)

The format of this parameter: 00YX

X = 0: It will not remain the digital output status

1: It will remain the digital output status

Y = 0: AL380 (position deviation) is not working

1: AL380 (position deviation) is working

Block diagram:

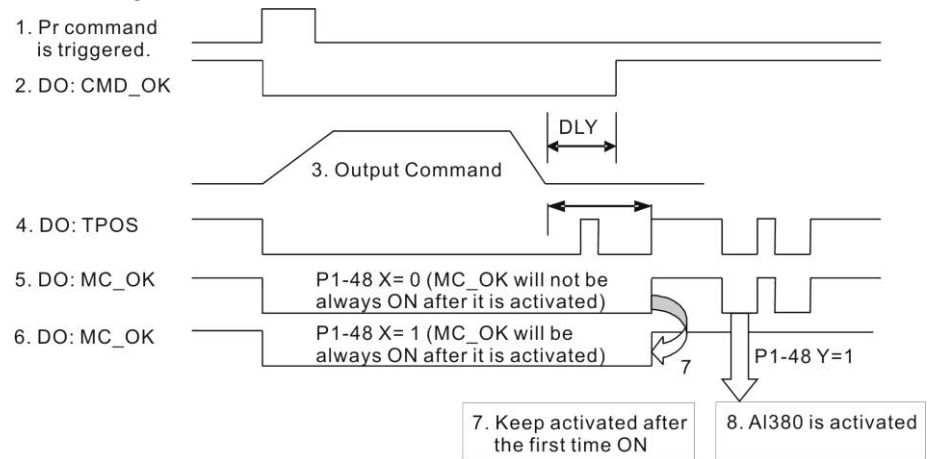

Description:

- 1. Command triggered:** It means the new PR command is effective. Position command starts to output and clear signal 2, 4, 5, 6 at the same time.
Command triggering source: DI.CTRG, DI.EV1/EV2, P5-07 (triggered through software), etc.
- 2. CMD_OK:** It means the position command is completely output and can set the delay time (DLY).
- 3. Command output:** Output the profile of position command according to the setting acceleration / deceleration.
- 4. TPOS:** It means the position error of the servo drive is smaller than the value of P1-54.
- 5. MC_OK:** It means the position command is completely output, which indicates that CMD_OK and TPOS are both on.
- 6. MC_OK (remains the digital output status):** It is the same as 5. However, once this DO is ON, its status will be remained regardless signal 4 is OFF or not.
- 7. Can only select one of signal 5 or signal 6 to output.** The output profile is determined by parameter P1-48.X.
- 8. Position Deviation:** When number 7 happens, if 4 (or 5) is OFF, it means the position is deviated and AL380 can be triggered. Set this alarm via parameter P1-48.Y.

P1-49	SPOKWT	Accumulative Time of Speed Reached		Address: 0162H 0163H
	Operational Interface :	Panel / Software	Communication	Related Section: Table 8.2
	Default :	0		
	Control Mode :	S / Sz		
	Unit :	ms		
	Range :	0 ~ 65535		
	Data Size :	16-bit		
	Format :	DEC		
Settings :	In speed mode, when the deviation value between speed command and motor feedback speed is smaller than the range set by P1-47 and reaches the time set by P1-79, DO.SP_OK (DI code: 0x19) will be On. If the deviation value exceeds the range set by P1-47, it has to reclock the time.			

P1-50 ~ P1-51	Reserved
----------------------	-----------------

P1-52	RES1	Regenerative Resistor Value		Address: 0168H 0169H
	Operational Interface :	Panel / Software	Communication	Related Section: 2.7
	Default :	Determined by the model. Please refer to the following table.		
	Control Mode :	ALL		
Unit :	Ohm			

Range :	220V	
	Model	Setting Range
	400 W (included) or below	30 ~ 750
	750 W ~ 1.5 kW	20 ~ 750
	2 kW ~ 4.5 kW	10 ~ 750
	5.5 kW	8 ~ 750
	7.5 kW	5 ~ 750
	11 kW	8 ~ 750
	15 kW	5 ~ 750
	400V	
	Model	Setting Range
	750 W ~ 1.5 kW	60 ~ 750
	1.5 kW ~ 2 kW	40 ~ 750
	3 kW	30 ~ 750
	4.5 kW ~ 5.5 kW	20 ~ 750
7.5 kW	15 ~ 750	
Data Size :	16-bit	
Format :	Decimal	

Settings : 220V:

Model	Default
1.5 kW (included) or below	40Ω
2 kW ~ 4.5 kW (included)	20Ω
5.5 kW	15Ω
7.5 kW	15Ω

400V:

Model	Default
750 W ~ 7.5 kW	80Ω

Please refer to the description of P1-53 for the setting value when connecting regenerative resistor with different method.

P1-53	RES2	Regenerative Resistor Capacity	Address: 016AH 016BH
	Operational Interface :	Panel / Software Communication	Related Section: 2.7
	Default :	Determined by the model. Please refer to the following table.	

Control Mode :	ALL
Unit :	Watt
Range :	0 ~ 6000 (for 11 kW and 15 kW, the setting range is from 0 to 15000)
Data Size :	16-bit
Format :	Decimal

Settings : 220V

Model	Default
200 W (included) or below	0 W
400 W	40 W
750 W ~ 1.5 kW	60 W
2 kW ~ 4.5 kW (included)	100 W
5.5 kW	0 W
7.5 kW	0 W

400V

Model	Default
750 W ~ 1.5 kW	40 W
2 kW ~ 7.5 kW	0 W

Following describes the setting value when connecting regenerative resistor with different method:

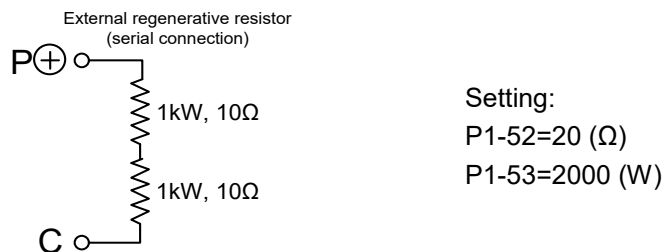
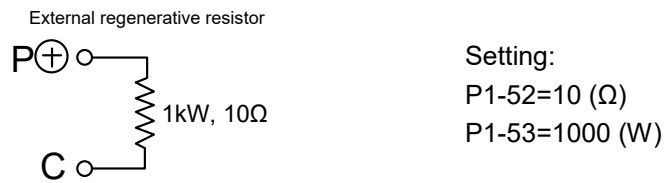

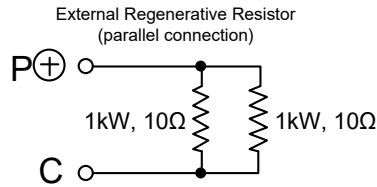

Setting:
 P1-52=5 (Ω)
 P1-53=2000 (W)

P1-54	PER	Position Completed Range		Address: 016CH 016DH
	Operational Interface :	Panel / Software	Communication	Related Section: Table 8.2
	Default :	12800		
	Control Mode :	PT / PR		
	Unit :	Pulse		
	Range :	0 ~ 1280000		
	Data Size :	32-bit		
	Format :	Decimal		

Settings : In position mode (PT), if the deviation pulse number is smaller than the setting range (the setting value of parameter P1-54), DO.TPOS is ON.
 In position register (PR) mode, if the deviation between the target position and the actual motor position is smaller than the setting range (the setting value of parameter P1-54), DO.TPOS is ON.

P1-55	MSPD	Maximum Speed Limit		Address: 016EH 016FH
	Operational Interface :	Panel / Software	Communication	Related Section: -
	Default :	Same as the rated speed of each model		
	Control Mode :	ALL		
	Unit :	r/min		
	Range :	10 ~ max.speed		
	Data Size :	16-bit		
	Format :	Decimal		

Settings : The default of the max. speed of servo motor is set to the rated speed.

P1-56	OVW	Output Overload Warning Level	Address: 0170H 0171H
	Operational Interface :	Panel / Software	Communication
	Default :	120	
	Control Mode :	ALL	
	Unit :	%	
	Range :	0 ~ 120	
	Data Size :	16-bit	
	Format :	Decimal	

Related Section: -

Settings : The setting value is 0 ~ 100, if the servo motor continuously outputs the load and is higher than the setting proportion (P1-56), the early warning for overload (DO is set to 10, OLW) will occur.
If the setting value is over 100, it will disable this function.

P1-57	CRSHA	Motor Crash Protection (torque percentage)	Address: 0172H 0173H
	Operational Interface :	Panel / Software	Communication
	Default :	0	
	Control Mode :	ALL	
	Unit :	%	
	Range :	0 ~ 300	
	Data Size :	16-bit	
	Format :	Decimal	

Related Section: -

Settings : Setup protection level (for the percentage of rated torque, set the value to 0 means to disable the function; set the value to 1 or number above means to enable the function)

P1-58	CRSHT	Motor Crash Protection Time		Address: 0174H 0175H
	Operational Interface :	Panel / Software	Communication	Related Section: -
	Default :	1		
	Control Mode :	ALL		
	Unit :	ms		
	Range :	1 ~ 1000		
	Data Size :	16-bit		
	Format :	Decimal		

Settings : Setup the protection time:
When it reaches the level, AL030 occurs after exceeding the protection time.

Note: This function is only suitable for non-contactable application, such as electric discharge machines. (Please setup P1-37 correctly).

P1-59	MFLT	Analog Speed Command		Address: 0176H 0177H
	Operational Interface :	Panel / Software	Communication	Related Section: -
	Default :	0.0	0	
	Control Mode :	S		
	Unit :	1 ms	0.1 ms	
	Range :	0.0 ~ 4.0	0 ~ 40	
	Data Size :	16-bit		
	Format :	One decimal	DEC	
Example :	1.5 = 1.5 ms	15 = 1.5 ms		

Settings : (Moving Filter)
0: Disabled

P1-06 is low-pass filter and P1-59 is moving filter. The difference between both is that moving filter can smooth the command in the beginning and end of the step command; while the low-pass filter brings better smooth effect to command end.

Therefore, it is suggested that if the speed loop receives the command from the controller for forming the position control loop, then low-pass filter can be used. If it is only for the speed control, then it should use Moving Filter for better smoothing.

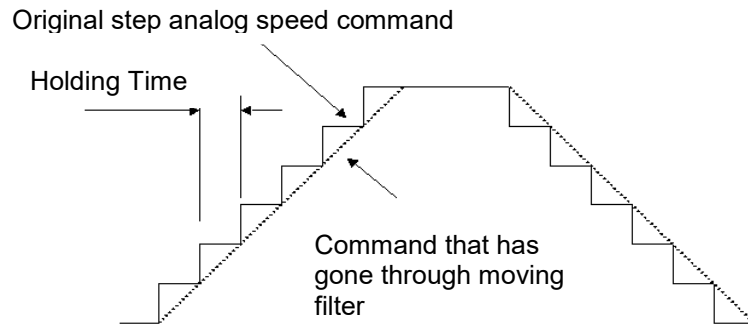

P1-60 ~ P1-61	Reserved
----------------------	-----------------

P1-62	FRCL	Friction Compensation	Address: 017CH 017DH
Operational Interface :	Panel / Software	Communication	Related Section: -
Default :	0		
Control Mode :	PT / PR / S		
Unit :	%		
Range :	0 ~ 100		
Data Size :	16-bit		
Format :	Decimal		

Settings : The level of friction compensation (the percentage of rated torque. Set the value to 0 means to disable the function; setting the value to 1 or number above means to enable this function.)

P1-63	FRCT	Friction Compensation		Address: 017EH 017FH
	Operational Interface :	Panel / Software	Communication	Related Section: -
	Default :	0		
	Control Mode :	PT / PR / S		
	Unit :	ms		
	Range :	1 ~ 1000		
	Data Size :	16-bit		
	Format :	Decimal		

Settings : Setup smoothing constant of friction compensation.

P1-64	PCCT	Analog Position Command: Activation Control		Address: 0180H 0181H
	Operational Interface :	Panel / Software	Communication	Related Section: -
	Default :	0x0000		
	Control Mode :	PT		
	Unit :	-		
	Range :	0x0000~0x0011		
	Data Size :	16-bit		
	Format :	Hexadecimal		

Settings :

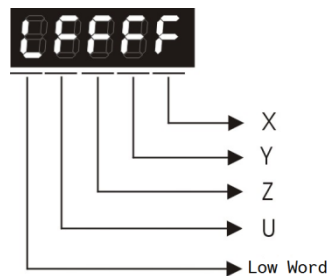

X:

- 0: Disable the function of position command which is issued by the analog signal
- 1: Enable the function of position command which is issued by the analog signal

Y: Initial position setting

0: After the servo is on, the motor will regard the current position as the position when the voltage is 0. Then the motor will operate to the position according to the analog input command.

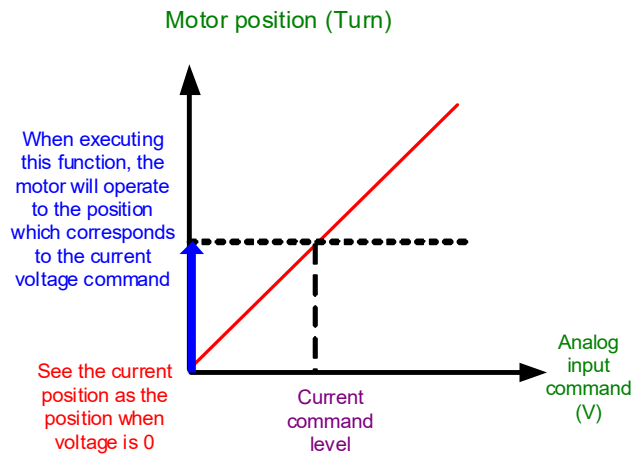

1: After the servo is on, if the command level is not changed, the motor will not operate. The position the motor stops at is the position that corresponds to the current command level.

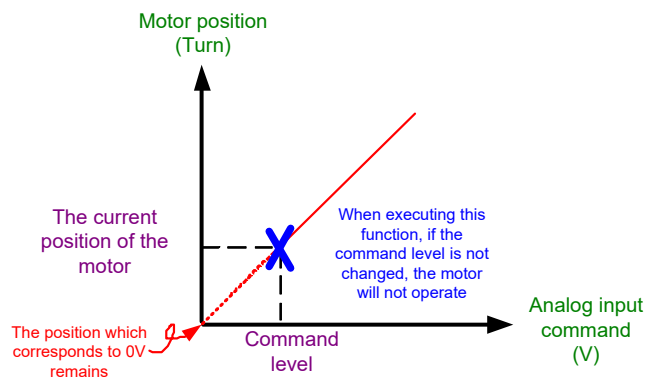

Z: Reserved
U: Reserved

Note: Version after firmware v1.031 sub8 supports this function.

P1-65	Smooth Constant of Analog Position Command		Address: 0182H 0183H
	Operational Interface :	Panel / Software	Communication
	Default :	1	
	Control Mode :	PT	
	Unit :	10 ms	
			Related Section: N/A

Range :	0 ~ 1000
Data Size :	16-bit
Format :	Decimal

Settings : The smooth constant of analog position command is only effective to analog position command.

Note: This function is available for firmware version v1.031 sub8 and above.

P1-66	PCM	Max. Rotation Number of Analog Position Command		Address: 0184H 0185H
	Operational Interface :	Panel / Software	Communication	Related Section: -
	Default :	0.0	0	
	Control Mode :	PT		
	Unit :	1 cycle	0.1 cycle	
	Range :	0.0 ~ 200.0	0 ~ 2000	
	Data Size :	16-bit		
	Format :	One decimal	DEC	
	Example :	1.5 = 1.5 cycles	15 = 1.5 cycles	

Settings : It is the rotation number setting when analog speed command inputs the max. voltage (10V). If it is set to 3.0 and the external voltage inputs 10V, it means the position command is +3 cycles. 5V means the speed control command is 1.5 cycles.

-10V means the position command is -3 cycles.

Position control command = Input voltage value x Setting value/10

Note: This function is available for firmware version v1.031 sub8 and above.

P1-67	Reserved			
--------------	-----------------	--	--	--

P1-68	PFLT2	Position Command Moving Filter		Address: 0188H 0189H
	Operational Interface :	Panel / Software	Communication	Related Section: -
	Default :	4		
	Control Mode :	PT / PR		
Unit :	ms			

Range :	0 ~ 100
Data Size :	16-bit
Format :	Decimal

Settings : 0: Disabled

Moving Filter can activate smooth function in the beginning and the end of step command, but it will delay the command.

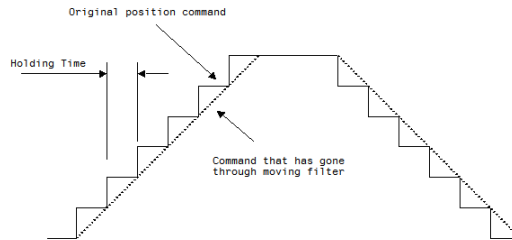

P1-69 ~ P1-71	Reserved
----------------------	-----------------

P1-72	FRES	Resolution of Linear Scale for Full-closed Loop Control	Address: 0190H 0191H
Operational Interface :	Panel / Software	Communication	Related Section: -
Default :	5000		
Control Mode :	PT		
Unit :	pulse/rev		
Range :	4 ~1800000		
Data Size :	32-bit		
Format :	Decimal		

Settings : A/B pulse corresponded by full-closed loop when motor runs a cycle (after quadruple frequency)

P1-73	FERR	Error Protection Range for Full-closed Loop Control		Address: 0192H 0193H
	Operational Interface :	Panel / Software	Communication	Related Section: P2-34
	Default :	30000		
	Control Mode :	PT		
	Unit :	Pulse (based on the feedback of full-closed loop)		
	Range :	1 ~ (2 ³¹ -1)		
	Data Size :	32-bit		
	Format :	Decimal		

Settings : The protection is for excessive deviation between feedback position of linear scale A/B Counter and the encoder. When the deviation is excessive, it might result from the loose of connector or other mechanism problems.

P1-74▲	FCON	Full-closed Loop Control of Linear Scale		Address: 0194H 0195H
	Operational Interface :	Panel / Software	Communication	Related Section: P1-46
	Default :	0x0000		
	Control Mode :	PT		
	Unit :	-		
	Range :	0x0000 ~ 0x4122		
	Data Size :	16-bit		
	Format :	Hexadecimal		

Settings :

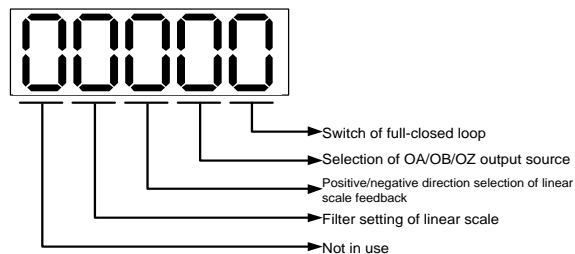

- Switch of full-closed loop control
 - 0: Function of full-closed loop is not used
 - 1: Function of full-closed loop is used
 - 2: Use the function of synchronous control
- Selection of OA/OB/OZ output source
 - 0: Motor encoder is the output source
 - 1: Encoder of linear scale is the output source
 Firmware version DSP V1.016 + CPLD 0.07(or the later version) will provide:
 - 2: Pulse command of CN1 is the output source
- Positive / negative direction selection of linear scale feedback:
 - 0: It is in positive direction when A phase leads B phase of linear scale
 - 1: It is in negative direction when B phase leads A phase of linear scale
- Filter setting of linear scale
 - 0: Bypass
 - 1: 6.66 M
 - 2: 1.66 M
 - 3: 833 K
 - 4: 416 K

P1-75	FELP	Low-pass Filter Time Constant of Full-closed Loop control		Address: 0196H 0197H
	Operational Interface :	Panel / Software	Communication	Related Section: -
	Default :	100		
	Control Mode :	PT		
	Unit :	ms		
	Range :	0 ~ 1000		
	Data Size :	16-bit		
	Format :	Decimal		

Settings : When the stiffness of mechanical system between full- and half-closed loops is insufficient, users can set the appropriate time constant to enhance the stability of the system. In other words, temporarily create the half-closed loop effect, and after stabilizing, the full-closed loop effect is created. When the stiffness is sufficient, set to bypass.

Set the value to 0 to disable the function of low-pass filter (Bypass)

The stiffness of mechanical system ↑, the setting value of P1-75 ↓

The stiffness of mechanical system ↓, the setting value of P1-75 ↑

P1-76	AMSPD	Maximum Rotation of Encoder Output Setting (OA, OB)		Address: 0198H 0199H
	Operational Interface :	Panel / Software	Communication	Related Section: P1-46
	Default :	5500		
	Control Mode :	ALL		
	Unit :	r/min		
	Range :	0 ~ 6000		
	Data Size :	16-bit		
	Format :	Decimal		

Settings : According to the real application, this parameter is set for the maximum speed and the servo drive will generate smooth function automatically for encoder output signals.

When the value is set to 0, the function is disabled.

P1-77 ~ P1-80	Reserved
--------------------------	-----------------

P1-81	VCM2	Max. Speed of 2nd Analog Speed Command		Address: 01A2H 01A3H
	Operational Interface :	Panel / Software	Communication	Related Section: P1-40
	Default :	Motor rated speed		
	Control Mode :	S / T		
	Unit :	rpm/10V		
	Range :	0 ~ 50000		
	Data Size :	32-bit		
	Format :	Decimal		

Settings : Please refer to the description of P1-40.

P1-82	VCMLPF	Filter Switching Time between P1-40 and P1-81		Address: 01A4H 01A5H
	Operational Interface :	Panel / Software	Communication	Related Section:
	Default :	0		
	Control Mode :	S		
	Unit :	msec		
	Range :	0 ~ 1000 (0: disable this function)		
	Data Size :	16-bit		
	Format :	Decimal		

Settings : 0: Disabled

P1-83	VCMLPF	Abnormal Analog Input Voltage Level		Address: 01A6H 01A7H
	Operational Interface :	Panel / Software	Communication	Related Section:
	Default :	0		
	Control Mode :	S		
	Unit :	mV		
	Range :	0 ~ 12000 (0: disable this function)		
	Data Size :	16-bit		
	Format :	Decimal		

Settings : When the analog input voltage is higher than the setting value for over 50 ms, AL042 will occur. The compared level for this parameter is the original analog input voltage which has not been added by an offset value via parameter P4-22, Analog Speed Input Offset.

P1-87	HMTQL	Torque Limit Setting		Address: 01A8H 01A9H
	Operational Interface :	Panel / Software	Communication	Related Section:
	Default :	1		
	Control Mode :	PR		
	Unit :	%		
	Range :	0 ~ 300		
	Data Size :	16-bit		
	Format :	Decimal		

Settings : The Torque limit setting is only for torque limit homing mode. As shown in the following diagram, when the homing command is triggered, the motor runs in one direction until it reaches the Hard Stop protector. After reaching the Hard Stop protector, the servo drive outputs a larger motor current to counter the external force from the Hard Stop protector. The servo drive uses the motor current and the Torque limit time to determine homing, and then it runs the opposite direction to find the Z pulse.

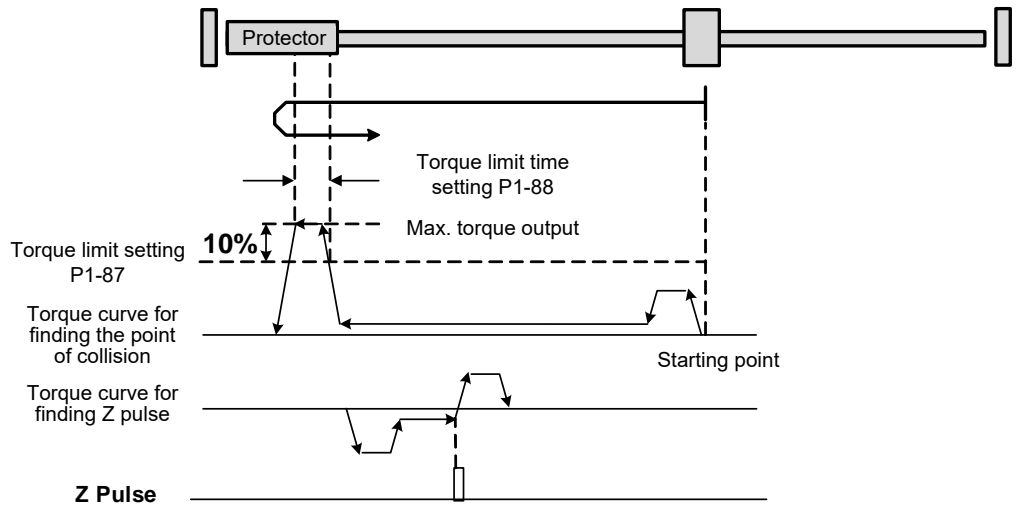

Note: the actual max. torque output of the motor is 10% higher than the torque limit setting (P1-87). For Example, if you set the torque limit P1-87 to 50%, and the max. torque output of the motor will be 60%.

P1-88	HMTQT	Torque Limit Time Setting		Address: 01AAH 01ABH
	Operational Interface :	Panel / Software	Communication	Related Section:
	Default :	2000		
	Control Mode :	PR		
	Unit :	ms		
	Range :	0 ~ 2000		
	Data Size :	16-bit		
	Format :	Decimal		

Settings : Torque limit time setting in torque limit homing mode.

P1-98		Disconnection detection protection (UVW) response time		Address: 01CAH 01CBH
	Operational Interface :	Panel / Software	Communication	Related Section:
	Default :	0		
	Control Mode :	All		
	Unit :	mV		
	Range :	0, 100 ~ 800		
	Data Size :	16-bit		
	Format :	DEC		

Settings : when the disconnection detection protection (UVW) function is enabled (P2-65 [Bit 9] = 1), select the response time of the detection mode with this parameter.

Set P1-98 to 0 to use the servo's default response time.

When P1-98 is not set to 0, the the detection response time range should be between 100 and 800.

Note:

1. If it is necessary to shorten the response time, it is recommended that you use this parameter.
2. When the servo is on and has not started running, it is recommended that you set this parameter if you need to detect disconnection.

P2-xx Extension Parameters

P2-00	KPP	Position Loop Gain		Address: 0200H 0201H
Operational Interface :	Panel / Software	Communication		Related Section: 6.2.8
Default :	35			
Control Mode :	PT / PR			
Unit :	rad/s			
Range :	0 ~ 2047			
Data Size :	16-bit			
Format :	Decimal			

Settings : When the value of position control gain is increased, the position response can be enhanced and the position error can be reduced. If the value is set too big, it may easily cause vibration and noise.

P2-01	PPR	Switching Rate of Position Loop Gain		Address: 0202H 0203H
Operational Interface :	Panel / Software	Communication		Related Section: 6.2.8
Default :	100			
Control Mode :	PT / PR			
Unit :	%			
Range :	10 ~ 500			
Data Size :	16-bit			
Format :	Decimal			

Settings : Switch the changing rate of position control gain according to the gain-switching condition.

P2-02	PFG	Position Feed Forward Gain	Address: 0204H 0205H
Operational Interface :	Panel / Software	Communication	Related Section: 6.2.8
Default :	50		
Control Mode :	PT / PR		
Unit :	%		
Range :	0 ~ 100		
Data Size :	16-bit		
Format :	Decimal		

Settings : If the position control command is changed smoothly, increasing the gain value can reduce the position error.
If the position control command is not changed smoothly, decreasing the gain value can tackle the problem of mechanical vibration.

P2-03	PFF	Smooth Constant of Position Feed Forward Gain	Address: 0206H 0207H
Operational Interface :	Panel / Software	Communication	Related Section: -
Default :	5		
Control Mode :	PT / PR		
Unit :	ms		
Range :	2 ~ 100		
Data Size :	16-bit		
Format :	Decimal		

Settings : If the position control command is changed smoothly, decreasing the value can reduce the position error. If the position control command is not changed smoothly, increasing the value can tackle the problem of mechanical vibration.

P2-04	KVP	Speed Loop Gain		Address: 0208H 0209H
	Operational Interface :	Panel / Software	Communication	Related Section: 6.3.6
	Default :	500		
	Control Mode :	ALL		
	Unit :	rad/s		
	Range :	0 ~ 8191		
	Data Size :	16-bit		
	Format :	Decimal		

Settings : Increase the value of speed control gain can enhance the speed response. However, if the value is set too big, it would easily cause resonance and noise.

P2-05	SPR	Switching Rate of Speed Loop Gain		Address: 020AH 020BH
	Operational Interface :	Panel / Software	Communication	Related Section: -
	Default :	100		
	Control Mode :	ALL		
	Unit :	%		
	Range :	10 ~ 500		
	Data Size :	16-bit		
	Format :	Decimal		

Settings : Switch the changing rate of speed control gain according to the gain switching condition.

P2-06	KVI	Speed Integral Compensation		Address: 020CH 020DH
	Operational Interface :	Panel / Software	Communication	Related Section: 6.3.6
	Default :	100		
	Control Mode :	ALL		
	Unit :	rad/s		
	Range :	0 ~ 1023		
	Data Size :	16-bit		
	Format :	Decimal		

Settings : Increasing the value of speed control integral compensation can enhance speed response and diminish the deviation of speed control. However, if the value is set too big, it would easily cause resonance and noise.

P2-07	KVF	Speed Feed Forward Gain		Address: 020EH 020FH
	Operational Interface :	Panel / Software	Communication	Related Section: 6.3.6
	Default :	0		
	Control Mode :	ALL		
	Unit :	%		
	Range :	0 ~ 100		
	Data Size :	16-bit		
	Format :	Decimal		

Settings : When the speed control command runs smoothly, increasing the gain value can reduce the speed command error. If the command does not run smoothly, decreasing the gain value can reduce the mechanical vibration during operation.

P2-08	PCTL	Special Parameter Write-in		Address: 0210H 0211H
	Operational Interface :	Panel / Software	Communication	Related Section: -
	Default :	0		
	Control Mode :	ALL		
	Unit :	-		
	Range :	0 ~ 501		
	Data Size :	16-bit		
	Format :	Decimal		

Settings : Special parameter write-in:

Parameter code	Function
10	Reset the parameter (Apply to the power again after reset)
20	P4-10 is writable
22	P4-11 ~ P4-21 are writable
30, 35	Save the data of COMPARE, CAPTURE, and E-Cam
406	Enable forced DO mode
400	When forced DO mode is enabled, it can switch back to the normal DO mode.

Note: A2-L does not support E-Cam function.

P2-09	DRT	DI Debouncing Time		Address: 0212H 0213H
	Operational Interface :	Panel / Software	Communication	Related Section: -
	Default :	2		
	Control Mode :	ALL		
	Unit :	ms		
	Range :	0 ~ 20		
	Data Size :	16-bit		
	Format :	Decimal		
	Example :	4 = 8 ms		

Settings : When the environmental noise is big, increasing the setting value can enhance the control stability. However, if the value is set too big, the response time will be influenced.

P2-10	DI1	DI1 Functional Planning	Address: 0214H 0215H
	Operational Interface :	Panel / Software	Communication
	Default :	0x0101	
	Control Mode :	ALL	
	Unit :	-	
	Range :	0x0000 ~ 0x015F (the last two codes are DI codes)	
	Data Size :	16-bit	
	Format :	Hexadecimal	

Settings :

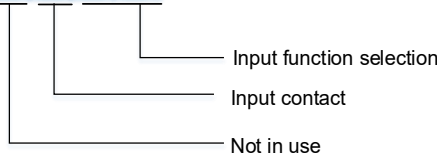

- Input function selection: Please refer to Table 8.1
 - Input contact: **a** or **b** contact
 - 0: Set the input contact as normally closed (**b** contact)
 - 1: Set the input contact as normally opened (**a** contact)
- (P2-10 ~ P2-17) The setting value of function programmed

When parameters are modified, please re-start the servo drive to ensure it can work normally.

Note: Parameter P3-06 is used to set how digital inputs (DI) accept commands, through external terminal or the communication determined by P4-07.

P2-11	DI2	DI2 Functional Planning	Address: 0216H 0217H
	Operational Interface :	Panel / Software	Communication
	Default :	0x0104	
	Control Mode :	ALL	
	Unit :	-	

Range :	0x0000 ~ 0x015F (the last two codes are DI codes)
Data Size :	16-bit
Format :	Hexadecimal

Settings : Please refer to the description of P2-10.

P2-12	DI3	DI3 Functional Planning		Address: 0218H 0219H
	Operational Interface :	Panel / Software	Communication	Related Section: Table 8.1
	Default :	0x0116		
	Control Mode :	ALL		
	Unit :	-		
	Range :	0x0000 ~ 0x015F (the last two codes are DI codes)		
	Data Size :	16-bit		
	Format :	Hexadecimal		

Settings : Please refer to the description of P2-10.

P2-13	DI4	DI4 Functional Planning		Address: 021AH 021BH
	Operational Interface :	Panel / Software	Communication	Related Section: Table 8.1
	Default :	0x0117		
	Control Mode :	ALL		
	Unit :	-		
	Range :	0x0000 ~ 0x015F (the last two codes are DI codes)		
	Data Size :	16-bit		
	Format :	Hexadecimal		

Settings : Please refer to the description of P2-10.

P2-14	DI5	DI5 Functional Planning		Address: 021CH 021DH
	Operational Interface :	Panel / Software	Communication	Related Section: Table 8.1
	Default :	0x0102		
	Control Mode :	ALL		
	Unit :	-		
	Range :	0x0000 ~ 0x015F (the last two codes are DI codes)		
	Data Size :	16-bit		
	Format :	Hexadecimal		

Settings : Please refer to the description of P2-10.

P2-15	DI6	DI6 Functional Planning		Address: 021EH 021FH
	Operational Interface :	Panel / Software	Communication	Related Section: Table 8.1
	Default :	0x0022		
	Control Mode :	ALL		
	Unit :	-		
	Range :	0x0000 ~ 0x015F (the last two codes are DI codes)		
	Data Size :	16-bit		
	Format :	Hexadecimal		

Settings : Please refer to the description of P2-10.

P2-16	DI7	DI7 Functional Planning		Address: 0220H 0221H
	Operational Interface :	Panel / Software	Communication	Related Section: Table 8.1
	Default :	0x0023		
	Control Mode :	ALL		
	Unit :	-		

Range :	0x0000 ~ 0x015F (the last two codes are DI codes)
Data Size :	16-bit
Format :	Hexadecimal

Settings : Please refer to the description of P2-10.

P2-17	DI8	DI8 Functional Planning	Address: 0222H 0223H
	Operational Interface :	Panel / Software	Communication
	Default :	0x0021	
	Control Mode :	ALL	
	Unit :	-	
	Range :	0x0000 ~ 0x015F (the last two codes are DI codes)	
	Data Size :	16-bit	
	Format :	Hexadecimal	

Related Section:
Table 8.1

Settings : Please refer to the description of P2-10.

P2-18	DO1	DO1 Functional Planning	Address: 0224H 0225H
	Operational Interface :	Panel / Software	Communication
	Default :	0x0101	
	Control Mode :	ALL	
	Unit :	-	
	Range :	0x0000 ~ 0x013F (the last two codes are DO codes)	
	Data Size :	16-bit	
	Format :	Hexadecimal	

Related Section:
Table 8.2

Settings :



Output function selection

Output contact

Not in use

- Output function selection: Please refer to Table 8.2
 - Output contact: **a** or **b** contact
 - 0: Set the output contact as normally closed (**b** contact)
 - 1: Set the output contact as normally opened (**a** contact)
- (P2-18 ~ P2-22) The setting value of function programmed
 When parameters are modified, please re-start the servo drive to ensure it can work normally.

P2-19	DO2	DO2 Functional Planning		Address: 0226H 0227H
Operational Interface :	Panel / Software	Communication		Related Section: Table 8.2
Default :	0x0103			
Control Mode :	ALL			
Unit :	-			
Range :	0x0000 ~ 0x013F (the last two codes are DO codes)			
Data Size :	16-bit			
Format :	Hexadecimal			

Settings : Please refer to the description of P2-18.

P2-20	DO3	DO3 Functional Planning		Address: 0228H 0229H
Operational Interface :	Panel / Software	Communication		Related Section: Table 8.2
Default :	0x0109			
Control Mode :	ALL			
Unit :	-			
Range :	0x0000 ~ 0x013F (the last two codes are DO codes)			
Data Size :	16-bit			

Format :	Hexadecimal
----------	-------------

Settings : Please refer to the description of P2-18.

P2-21	DO4	DO4 Functional Planning		Address: 022AH 022BH
	Operational Interface :	Panel / Software	Communication	Related Section: Table 8.2
	Default :	0x0105		
	Control Mode :	ALL		
	Unit :	-		
	Range :	0x0000 ~ 0x013F (the last two codes are DO codes)		
	Data Size :	16-bit		
	Format :	Hexadecimal		

Settings : Please refer to the description of P2-18.

P2-22	DO5	DO5 Functional Planning		Address: 022CH 022DH
	Operational Interface :	Panel / Software	Communication	Related Section: Table 8.2
	Default :	0x0007		
	Control Mode :	ALL		
	Unit :	-		
	Range :	0x0000 ~ 0x013F (the last two codes are DO codes)		
	Data Size :	16-bit		
	Format :	Hexadecimal		

Settings : Please refer to the description of P2-18.

P2-23	NCF1	Resonance Suppression (Notch filter) (1)		Address: 022EH 022FH
	Operational Interface :	Panel / Software	Communication	Related Section: 6.3.7
	Default :	1000		
	Control Mode :	ALL		
	Unit :	Hz		
	Range :	50 ~ 1000		
	Data Size :	16-bit		
	Format :	Decimal		

Settings : The first setting value of resonance frequency. If P2-24 is set to 0, this function is disabled. P2-43 and P2-44 are the second Notch filter.

P2-24	DPH1	Resonance Suppression (Notch filter) Attenuation Rate (1)		Address: 0230H 0231H
	Operational Interface :	Panel / Software	Communication	Related Section: 6.3.7
	Default :	0		
	Control Mode :	ALL		
	Unit :	-dB		
	Range :	0 ~ 32 (0: disable the function of Notch filter)		
	Data Size :	16-bit		
	Format :	Decimal		

Settings : The first resonance suppression (notch filter) attenuation rate. When this parameter is set to 0, the function of Notch filter is disabled.

Note: If the value of attenuation rate is set to 5, then, it would be -5 dB.

P2-25	NLP	Low-pass Filter of Resonance Suppression		Address: 0232H 0233H
	Operational Interface :	Panel / Software	Communication	Related Section: 6.3.7
	Default :	0.2 (under 1 kW) or 0.5 (other models)	2 (under 1 kW) or 5 (other models)	
Control Mode :	ALL			

Unit :	1 ms	0.1 ms
Range :	0.0 ~ 100.0	0 ~ 1000
Data Size :	16-bit	
Format :	One decimal	DEC
Example :	1.5 = 1.5 ms	15 = 1.5 ms

Settings : Set the low-pass filter of resonance suppression. When the value is set to 0, the function of low-pass filter is disabled.

P2-26	DST	Anti-interference Gain		Address: 0234H 0235H
	Operational Interface :	Panel / Software	Communication	Related Section: -
	Default :	0		
	Control Mode :	ALL		
	Unit :	rad/s		
	Range :	0 ~ 1023 (0: disable this function)		
	Data Size :	16-bit		
	Format :	Decimal		

Settings : Increasing the value of this parameter can increase the damping of speed loop. It is suggested to set P2-26 equals to the value of P2-06. If users desire to adjust P2-26, please follow the rules below.

1. In speed mode, increase the value of this parameter can reduce speed overshoot.
2. In position mode, decrease the value of this parameter can reduce position overshoot.

P2-27	GCC	Gain Switching and Switching Selection		Address: 0236H 0237H
	Operational Interface :	Panel / Software	Communication	Related Section: -
	Default :	0x0000		
Control Mode :	ALL			

Unit :	-
Range :	0x0000 ~ 0x0018
Data Size :	16-bit
Format :	Hexadecimal

Settings :

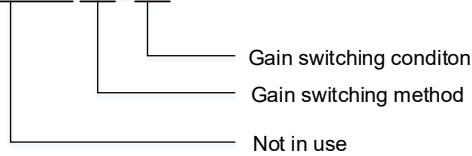

- Gain switching condition:
 - 0: Disable gain switching function.
 - 1: The signal of gain switching (GAINUP) is ON.
 - 2: In position control mode, the position error is bigger than the value of P2-29.
 - 3: The frequency of position command is bigger than the value of P2-29.
 - 4: When the speed of servo motor is faster than the value of P2-29.
 - 5: The signal of gain switching (GAINUP) is OFF.
 - 6: In position control mode, the position error is smaller than the value of P2-29.
 - 7: When the frequency of position command is smaller than the value of P2-29.
 - 8: When the speed of servo motor is slower than the value of P2-29.
- Gain switching method:
 - 0: Gain switching
 - 1: Integrator switching, P -> PI

Setting Value	Control Mode P	Control Mode S	
0	P2-00 x 100% P2-04 x 100%	P2-04 x 100%	Before switching
	P2-00 x P2-01 P2-04 x P2-05	P2-04 x P2-05	After switching
1	P2-06 x 0% P2-26 x 0%		Before switching
	P2-06 x 100% P2-26 x 100%		After switching

P2-28	GUT	Gain Switching Time Constant	Address: 0238H 0239H
Operational Interface :	Panel / Software	Communication	Related Section: -
Default :	10		
Control Mode :	ALL		
Unit :	10 ms		
Range :	0 ~ 1000		
Data Size :	16-bit		
Format :	Decimal		
Example :	15 = 150 ms		
Settings :	It is for switching the smooth gain. (0: disable this function)		

P2-29	GPE	Gain Switching	Address: 023AH 023BH
Operational Interface :	Panel / Software	Communication	Related Section: -
Default :	1280000		
Control Mode :	ALL		
Unit :	pulse, Kpps, r/min		
Range :	0 ~ 3840000		
Data Size :	32-bit		
Format :	Decimal		
Settings :	The setting of gain switching (pulse error, Kpps, r/min) is determined by the selection of gain switching (P2-27).		

P2-30	INH	Auxiliary Function	Address: 023CH 023DH
Operational Interface :	Panel / Software	Communication	Related Section: -
Default :	0		
Control Mode :	ALL		
Unit :	-		
Range :	-8 ~ +8		
Data Size :	16-bit		
Format :	Decimal		

Settings : 0: Disable all functions described below

1: Force to Servo On the software

2 ~ 4: (reserved)

5: This setting allows the written parameters not retain after power off. When the data is no need to save, it can avoid the parameters continuously writing into EEPROM and shortening the lifetime of EEPROM.

Setting this parameter is a must when using communication control.

6: In simulation mode (command simulation), the external Servo On signal cannot work and DSP Error (variable 0x6F) is regarded as 0. Parameter P0-01 only shows the external Error (positive/negative limit, emergency stop, etc)

In this status, DO.SRDY is ON. Command is accepted in each mode and can be observed via scope software. However, the motor will not operate. The aim is to examine the command accuracy.

7: (It will be available after firmware version V1.013)

High-speed oscilloscope, disable Time-Out function (It is for PC software)

8: (It will be available after firmware version V1.013)

Back up all parameters (current value) and save in EEPROM. The value still exists when re-power on.

The panel displays "to.rom" during execution. (It can be executed when Servo ON.)

-1, -5, -6, -7: (It will be available after firmware version V1.013)

Individually disable the function of 1,5,6,7

-2 ~ -4, -8: (Reserved)

Note: Please set the value to 0 in normal operation. The value returns to 0 automatically after re-power on.

P2-31	AUT1	Speed Loop Frequency Response Setting in Auto and Semi-auto Mode		Address: 023EH 023FH
	Operational Interface :	Panel / Software	Communication	Related Section: 5.6 and 6.3.6
	Default :	40		
	Control Mode :	ALL		
	Unit :	Hz		
	Range :	1 ~ 1000		
	Data Size :	16-bit		
	Format :	Decimal		

Settings : 1 ~ 50 Hz: Low stiffness, low response
 51 ~ 250 Hz: Medium stiffness, medium response
 251 ~ 850 Hz: High stiffness, high response
 851 ~ 1000 Hz: Extremely high stiffness, extremely high response

- Note: 1) According to the speed loop setting of P2-31, the servo drive sets the position loop response automatically.
 2) The function is enabled via parameter P2-32. Please refer to section 5.6 for corresponding bandwidth size of the setting value.

P2-32 ▲	AUT2	Tuning Mode Selection		Address: 0240H 0241H
	Operational Interface :	Panel / Software	Communication	Related Section: 5.6 and 6.3.6
	Default :	0x0000		
	Control Mode :	ALL		
	Unit :	-		
	Range :	0x0000 ~ 0x0002		
	Data Size :	16-bit		
	Format :	Hexadecimal		

Settings : 0: Manual Mode
 1: Auto Mode (continuous adjustment)
 2: Semi-auto Mode (non-continuous adjustment)

Relevant description of manual mode setting:

When P2-32 is set to 0, parameters related to gain control, such as P2-00, P2-04, P2-06, P2-25 and P2-26, all can be set by the user.

When switching mode from auto or semi-auto to manual, parameters about gain will be updated automatically.

Relevant description of auto mode setting:

Continue to estimate the system inertia, save the inertia ratio to P1-37 every 30 minutes automatically and refer to the stiffness and bandwidth setting of P2-31.

1. Set the system to manual mode 0 from auto 1 or semi-auto 2, the system will save the estimated inertia value to P1-37 automatically and set the corresponding parameters.
2. Set the system to auto mode 1 or semi-auto mode 2 from manual mode 0, please set P1-37 to the appropriate value.
3. Set the system to manual mode 0 from auto mode 1, P2-00, P2-04, P2-06, P2-25, P2-26 and P2-49 will be modified to the corresponding parameters of auto mode.
4. Set the system to manual mode 0 from semi-auto mode 2, P2-00, P2-04, P2-06, P2-25, P2-26 and P2-49 will be modified to the corresponding parameters of semi-auto mode.

Relevant description of semi-auto mode setting:

1. When the system inertia is stable, the value of P2-33 will be 1 and the system stops estimating. The inertia value will be saved to P1-37 automatically. When switching mode to semi-auto mode (from manual or auto mode), the system starts to estimate again.
2. When the system inertia is over the range, the value of P2-33 will be 0 and the system starts to estimate and adjust again.

P2-33 ▲	AUT3	Semi-auto Inertia Adjustment		Address: 0242H 0243H
Operational Interface :	Panel / Software	Communication		Related Section: -
Default :	0x0000			
Control Mode :	ALL			
Unit :	-			
Range :	0x0000 ~ 0x0001			
Data Size :	16-bit			
Format :	Hexadecimal			

Settings :

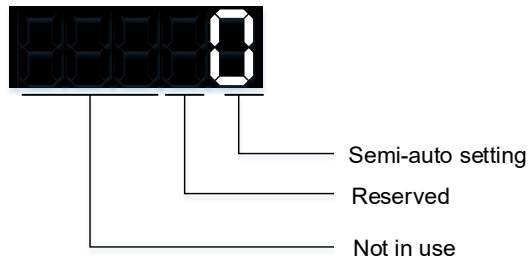

- Semi-auto Setting:
 - 1: It means the inertia estimation in semi-auto mode is completed. The inertia value can be accessed via P1-37.
 - 0: When the display is 0, it means the inertia adjustment is not completed and the adjustment is in progress.

When the setting is 0, it means the inertia adjustment is not completed and the adjustment is in progress.

P2-34	SDEV	The Condition of Overspeed Warning		Address: 0244H 0245H
	Operational Interface :	Panel / Software	Communication	Related Section: -
	Default :	5000		
	Control Mode :	S		
	Unit :	r/min		
	Range :	1 ~ 6000		
	Data Size :	16-bit		
	Format :	Decimal		

Settings : The setting of over speed warning in servo drive error display (P0-01)

P2-35	PDEV	Condition of Excessive Position Control Deviation Warning		Address: 0246H 0247H
	Operational Interface :	Panel / Software	Communication	Related Section: -
	Default :	3840000		
	Control Mode :	PT / PR		
	Unit :	pulse		
	Range :	1 ~ 128000000		
	Data Size :	32-bit		
	Format :	Decimal		

Settings : The setting of excessive position control deviation warning in servo drive error display (P0-01)

P2-36	EDI9	Extended EDI9 Functional Planning		Address: 0248H 0249H
	Operational Interface :	Panel / Software	Communication	Related Section: Table 8.1
	Default :	0x0000		
	Control Mode :	ALL		
	Unit :	-		
	Range :	0x0000 ~ 0x015F (the last two codes are EDI codes)		
	Data Size :	16-bit		
	Format :	Hexadecimal		

Settings :

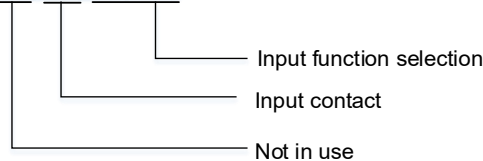

- Input function selection: Please refer to Table 8.1
 - Input contact: **a** or **b** contact
 - 0: Set the input contact as normally closed (**b** contact)
 - 1: Set the input contact as normally opened (**a** contact)
- (P2-36 ~ P2-41) The setting value of function programmed
When parameters are modified, please re-start the servo drive to ensure it can work normally.

P2-37	EDI10	Extended EDI10 Functional Planning		Address: 024AH 024BH
	Operational Interface :	Panel / Software	Communication	Related Section: Table 8.1
	Default :	0x0000		
	Control Mode :	ALL		
	Unit :	-		
	Range :	0x0000 ~ 0x015F (the last two codes are EDI codes)		
	Data Size :	16-bit		

Format :	Hexadecimal
----------	-------------

Settings : Please refer to the description of P2-36.

P2-38	EDI11	Extended EDI11 Functional Planning	Address: 024CH 024DH
	Operational Interface :	Panel / Software	Communication
	Default :	0x0000	
	Control Mode :	ALL	
	Unit :	-	
	Range :	0x0000 ~ 0x015F (the last two codes are EDI codes)	
	Data Size :	16-bit	
	Format :	Hexadecimal	

Related Section:
Table 8.1

Settings : Please refer to the description of P2-36.

P2-39	EDI12	Extended EDI12 Functional Planning	Address: 024EH 024FH
	Operational Interface :	Panel / Software	Communication
	Default :	0x0000	
	Control Mode :	ALL	
	Unit :	-	
	Range :	0x0000 ~ 0x015F (the last two codes are EDI codes)	
	Data Size :	16-bit	
	Format :	Hexadecimal	

Related Section
Table: 8.1

Settings : Please refer to the description of P2-36.

P2-40	EDI13	Extended EDI13 Functional Planning		Address: 0250H 0251H
	Operational Interface :	Panel / Software	Communication	Related Section: Table 8.1
	Default :	0x0000		
	Control Mode :	ALL		
	Unit :	-		
	Range :	0x0000 ~ 0x015F (the last two codes are EDI codes)		
	Data Size :	16-bit		
	Format :	Hexadecimal		

Settings : Please refer to the description of P2-36.

P2-41	EDI14	Extended EDI14 Functional Planning		Address: 0252H 0253H
	Operational Interface :	Panel / Software	Communication	Related Section: Table 8.1
	Default :	0x0000		
	Control Mode :	ALL		
	Unit :	-		
	Range :	0x0000 ~ 0x015F (the last two codes are EDI codes)		
	Data Size :	16-bit		
	Format :	Hexadecimal		

Settings : Please refer to the description of P2-36.

P2-42	Reserved
--------------	-----------------

P2-43	NCF2	Resonance Suppression (Notch filter) (2)	Address: 0256H 0257H
Operational Interface :	Panel / Software	Communication	Related Section: 6.3.7
Default :	1000		
Control Mode :	ALL		
Unit :	Hz		
Range :	50 ~ 2000		
Data Size :	16-bit		
Format :	Decimal		

Settings : The second setting value of resonance frequency. If P2-44 is set to 0, this function is disabled. P2-23 and P2-24 are the first Notch filter.

P2-44	DPH2	Resonance Suppression (Notch filter) Attenuation Rate (2)	Address: 0258H 0259H
Operational Interface :	Panel / Software	Communication	Related Section: 6.3.7
Default :	0		
Control Mode :	ALL		
Unit :	-dB		
Range :	0 ~ 32 (0: disable Notch filter)		
Data Size :	16-bit		
Format :	Decimal		

Settings : The second resonance suppression (notch filter) attenuation rate. When this parameter is set to 0, the function of Notch filter is disabled.

Note: If the value of attenuation rate is set to 5, then it would be -5 dB.

P2-45	NCF3	Resonance Suppression (Notch filter) (3)	Address: 025AH 025BH	
	Operational Interface :	Panel / Software	Communication	Related Section: 6.3.7
	Default :	1000		
	Control Mode :	ALL		
	Unit :	Hz		
	Range :	50 ~ 2000		
	Data Size :	16-bit		
	Format :	Decimal		
	Settings :	The third group of mechanism resonance frequency setting value. If P2-46 is set to 0, this function will be disabled. P2-23 and P2-24 are the first group of resonance suppression (Notch filter).		

P2-46	DPH3	Resonance Suppression (Notch filter) Attenuation Rate (3)	Address: 025CH 025DH	
	Operational Interface :	Panel / Software	Communication	Related Section: 6.3.7
	Default :	0		
	Control Mode :	ALL		
	Unit :	-dB		
	Range :	0 ~ 32		
	Data Size :	16-bit		
	Format :	Decimal		
	Settings :	The third group of resonance suppression (Notch filter) attenuation rate. Set the value to 0 to disable the function of Notch filter.		
	Note :	If the value of attenuation rate is set to 5, then it would be -5 dB.		

P2-47	ANCF	Auto Resonance Suppression Mode Setting	Address: 025EH 025FH	
	Operational Interface :	Panel / Software	Communication	Related Section: -
	Default :	1		

Control Mode :	ALL
Unit :	-
Range :	0 ~ 2
Data Size :	16-bit
Format :	Decimal

- Settings :
- 0: The value of P2-43, P2-44 and P2-45, P2-46 will retain.
 - 1: The value of P2-43, P2-44 and P2-45, P2-46 will retain after resonance suppression.
 - 2: Continuous resonance suppression

Description of Auto Mode Setting:

When it is set to 1: Auto resonance, the value returns to 0 automatically and saves the point of resonance suppression when it is stable. If it is unstable, re-power on or set back to 1 for re-estimation again.

When it is set to 2: Continuous suppression automatically. When it is stable, the point of resonance suppression will be saved. If it is unstable, re-power on for re-estimation.

When switching to mode 0 from mode 2 or 1, the setting of P2-43, P2-44, P2-45 and P2-46 will be saved automatically.

P2-48	ANCL	Resonance Suppression Detection Level		Address: 0260H 0261H
	Operational Interface :	Panel / Software	Communication	
Default :	100			
Control Mode :	ALL			
Unit :	-			
Range :	1 ~ 300			
Data Size :	16-bit			
Format :	Decimal			

Settings : (The smaller the setting value is, the more sensitive the resonance will be.)

P2-48↑, resonance sensitiveness↓

P2-48↓, resonance sensitiveness↑

P2-49	SJIT	Speed Detection Filter		Address: 0262H 0263H
	Operational Interface :	Panel / Software	Communication	Related Section: -
	Default :	0x000B		
	Control Mode :	ALL		
	Unit :	-		
	Range :	0x0000 ~ 0x001F		
	Data Size :	16-bit		
	Format :	Hexadecimal		

Settings : The filter of speed estimation

Setting Value	Speed Estimation Bandwidth (Hz)
00	2500
01	2250
02	2100
03	2000
04	1800
05	1600
06	1500
07	1400
08	1300
09	1200
0A	1100
0B	1000
0C	950
0D	900
0E	850
0F	800
10	750
11	700
12	650
13	600
14	550
15	500
16	450
17	400

Setting Value	Speed Estimation Bandwidth (Hz)
18	350
19	300
1A	250
1B	200
1C	175
1D	150
1E	125
1F	100

P2-50	CCLR	Pulse Clear Mode	Address: 0264H 0265H
	Operational Interface :	Panel / Software Communication	Related Section: -
	Default :	0x0000	
	Control Mode :	PT	
	Unit :	-	
	Range :	0x0000 ~ 0x0001	
	Data Size :	16-bit	
	Format :	Hexadecimal	

Settings : Please refer to Table 8.1 for digital input setting.

When you set digital input (DI) as CCLR, the function of pulse clear is effective. Clear the position error (It is applicable in PT and PR modes).

If this DI is ON, the accumulative position error will be cleared to 0.

0: CCLR is rising-edge triggered.

1: CCLR is action-level triggered.

P2-51	Reserved

P2-52 ▲	IDXS	Indexing Coordinates Scale		Address: 0268H 0269H
Operational Interface :	Panel / Software	Communication		Related Section:
Default :	1000000000			
Control Mode :	ALL			
Unit :	PUU			
Range :	0 ~ 1000000000			
Data Size :	32-bit			
Format :	Decimal			

Settings : This parameter is used to set the scale of the indexing coordinates, indexing command position and indexing feedback position. If the setting value is too small, it may cause the error of indexing coordinates.

Range of setting value of P2-52:

$$P2-52 > 1.05 \times \text{Max. Motor Speed (r/min)} \times \frac{1280000}{60000} \times \frac{P1-45}{P1-44}$$

$$> 22.4 \times \text{Max. Motor Speed (r/min)} \times \frac{P1-45}{P1-44}$$

P2-53	KPI	Position Integral Compensation		Address: 026AH 026BH
Operational Interface :	Panel / Software	Communication		Related Section: 6.3.6
Default :	0			
Control Mode :	ALL			
Unit :	rad/s			
Range :	0 ~ 1023			
Data Size :	16-bit			
Format :	Decimal			

Settings : When increasing the value of position control integral, reducing the position steady-state error, it may easily cause position overshoot and noise if the value is set too big.

P2-54 ▲	SVP	The Gain of Synchronous Speed Control	Address: 026CH 026DH
Operational Interface :	Panel / Software	Communication	Related Section: -
Default :	0		
Control Mode :	ALL		
Unit :	rad/s		
Range :	0 ~ 8191		
Data Size :	16-bit		
Format :	Decimal		

Settings : When increasing the value of synchronous speed control, it can enhance the speed following of two motors. However, if the value is set too big, it may easily cause vibration and noise.

P2-55 ▲	SVI	Integral Compensation to Synchronous Speed	Address: 026EH 026FH
Operational Interface :	Panel / Software	Communication	Related Section: -
Default :	0		
Control Mode :	ALL		
Unit :	rad/s		
Range :	0 ~ 1023		
Data Size :	16-bit		
Format :	Decimal		

Settings : When increasing integral compensation to synchronous speed, two motors speed following can be enhanced and the speed error between two motors can be reduced. However, if the value is set too big, it may easily cause vibration and noise.

P2-56 ▲	SPI	Integral Compensation to Synchronous Position	Address: 0270H 0271H
Operational Interface :	Panel / Software	Communication	Related Section: -
Default :	0		
Control Mode :	ALL		
Unit :	rad/s		
Range :	0 ~ 1023		
Data Size :	16-bit		
Format :	Decimal		

Settings : When increasing integral compensation to synchronous position, two motors speed following can be enhanced and the speed error between two motors can be reduced. However, if the value is set too big, it may easily cause vibration and noise. It is suggested to set the value the same as P2-06.

P2-57 ▲	SBW	The Bandwidth of Synchronous Control		Address: 0272H 0273H
	Operational Interface :	Panel / Software	Communication	
Default :	0			
Control Mode :	ALL			
Unit :	Hz			
Range :	0 ~ 1023			
Data Size :	16-bit			
Format :	Decimal			

Settings : If users do not know how to set P2-54 ~ P2-56, setting the bandwidth of synchronous control value will do since the value will correspond to P2-54 ~ P2-56. The bigger the bandwidth of synchronous control value is, the better the synchronous effect will be. When the bandwidth of speed loop plus the bandwidth of synchronous control is greater than the system's allowable bandwidth, it causes system resonance. When increasing the bandwidth of speed loop and synchronous control, pay special attention to the response of P2-25 which should be faster than the setting of the both bandwidth.

P2-58	SVL	Low-pass Filter of Synchronous Speed Error		Address: 0274H 0275H
	Operational Interface :	Panel / Software	Communication	
Default :	0			
Control Mode :	ALL			
Unit :	0.1 ms			
Range :	0 ~ 1000			
Data Size :	16-bit			
Format :	Decimal			
Example :	15 = 1.5 ms			

Settings : If the synchronous control is influenced by low resolution and causes noise (not a high-pitched but rough sound), low-pass filter can be used to solve this problem. Please note that bandwidth of the synchronous control should be set as large as possible and should be larger than the bandwidth of speed-loop.

P2-59	Reserved		
--------------	----------	--	--

P2-60	GR4	Gear Ratio (Numerator) (N2)		Address: 0278H 0279H
Operational Interface :		Panel / Software	Communication	Related Section: -
Default :		128		
Control Mode :		PT		
Unit :		pulse		
Range :		1 ~ (2 ²⁹ -1)		
Data Size :		32-bit		
Format :		Decimal		

Settings : The numerator of electronic gear ratio can be selected via DI.GNUM0 and DI.GNUM1 (Please refer to Table 8.1). If DI.GNUM0 and DI.GNUM1 are not set, P1-44 will automatically be the numerator of electronic gear ratio. Please switch GNUM0 and GNUM1 in stop status to avoid the mechanical vibration.

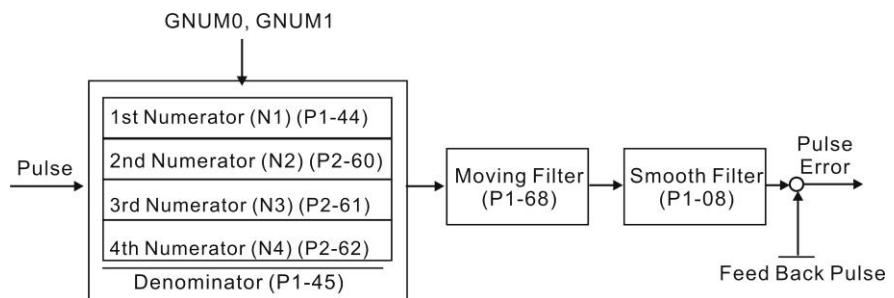

P2-61	GR5	Gear Ratio (Numerator) (N3)		Address: 027AH 027BH
Operational Interface :		Panel / Software	Communication	Related Section: -
Default :		128		
Control Mode :		PT		
Unit :		pulse		
Range :		1 ~ (2 ²⁹ -1)		

Data Size :	32-bit
Format :	Decimal

Settings : Please refer to the description of P2-60.

P2-62	GR6	Gear Ratio (Numerator) (N4)		Address: 027CH 027DH
	Operational Interface :	Panel / Software	Communication	Related Section: -
	Default :	128		
	Control Mode :	PT		
	Unit :	pulse		
	Range :	1 ~ (2 ²⁹ -1)		
	Data Size :	32-bit		
	Format :	Decimal		

Settings : Please refer to the description of P2-60.

**P2-63 ~
P2-64**

Reserved

P2-65	GBIT	Special-bit Register		Address: 0282H 0283H
	Operational Interface :	Panel / Software	Communication	Related Section: -
	Default :	0x0000		
	Control Mode :	PT / PR / S		
	Unit :	-		
	Range :	0x0000 ~ 0xFFFF		
	Data Size :	-		
	Format :	-		

Settings :

Bit7	Bit6	Bit5	Bit4	Bit3	Bit2	Bit1	Bit0
------	------	------	------	------	------	------	------

Bit15	Bit14	Bit13	Bit12	Bit11	Bit10	Bit9	Bit8
-------	-------	-------	-------	-------	-------	------	------

- Bit 4, Bit 7, and Bit14: Reserved, please set to 0.
- Bit 0 ~ Bit1
 - Bit 0: SPD0/SPD1 speed trigger mode
(0: action-level triggered; 1: rising-edge triggered)
 - Bit 1: TCM0/TCM1 torque trigger mode
(0: action-level triggered; 1: rising-edge triggered)
 When rising-edge is triggered, refer to the following for the setting of register command:

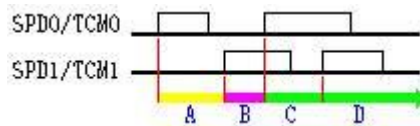

- A: Execute internal register command 1
- B: Execute internal register command 2
- C: Execute internal register command 3
- D: Execute internal register command 3
- Bit 2: IGBT software protection
 - 0: Enable the function of IGBT software protection
 - 1: Disable the function of IGBT software protection
- Bit 3: New regenerative brake function switch
 - 0: Disable the new regenerative brake function switch
 - 1: Enable the new regenerative brake function switch
 This function provides protection and detection when the mains voltage is too high.
- Bit 5: Detection for undervoltage and phase loss
 - 0: When Servo off, disable the detection for undervoltage and phase loss.
 - 1: When Servo off, enable the detection for undervoltage and phase loss.
- Bit 6: In PT mode, the switch of pulse error protection function (pulse frequency is over high)
 - 0: Normally use the function of pulse error protection
 - 1: Disable the function of pulse error protection
- Bit 8: U, V, W wiring error protection
 - 1: Enable U, V, W wiring error protection
- Bit 9: U, V, W wiring cut-off detection
 - 1: Enable U, V, W wiring cut-off detection
- Bit 10: DI.ZCLAMP function selection
 - When the following conditions are all established, the function of ZCLAMP is enabled.
 - Condition 1: speed mode
 - Condition 2: DI. ZCLAMP is on.
 - Condition 3: Motor speed is slower than the value of P1-38.

0: The command source is analog, ZCLAMP function will use the analog speed command without acceleration / deceleration processing to judge if this function should be enabled. The motor will be locked at the position where ZCALMP conditions are established.

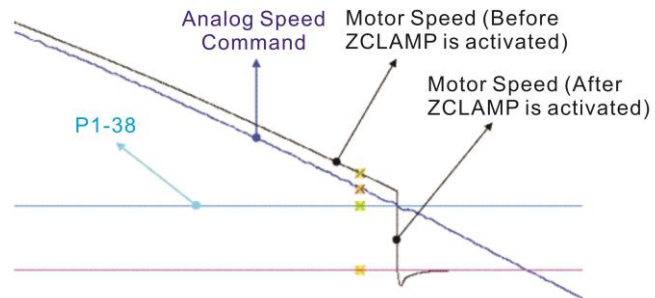

0: The command source is register. ZCLAMP function will use the register speed command with acceleration / deceleration processing to judge if this function is enabled. The motor will be locked at the position where ZCALMP conditions are established.

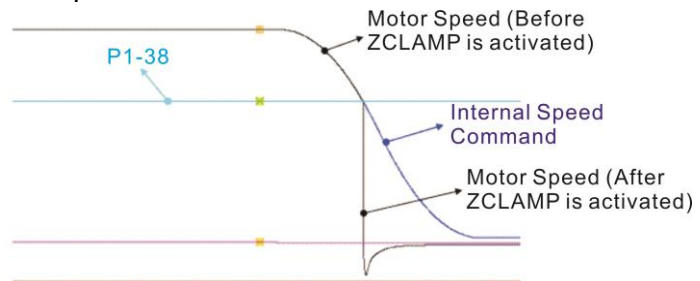

1: The command source is analog speed command. ZCLAMP function will use the analog speed command without acceleration / deceleration processing to judge if this function is enabled. When ZCALMP conditions are established, the motor speed decelerates to 0 through S-curve. If not, the motor follow the analog speed command through S-curve.

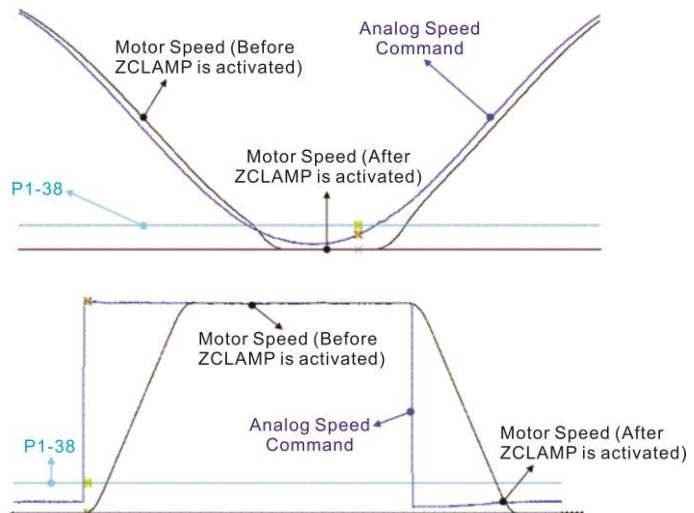

1: The command source is register. ZCLAMP function will use the register with acceleration / deceleration processing to judge if this function is enabled. When ZCLAMP conditions are established, the motor speed will be set to 0.

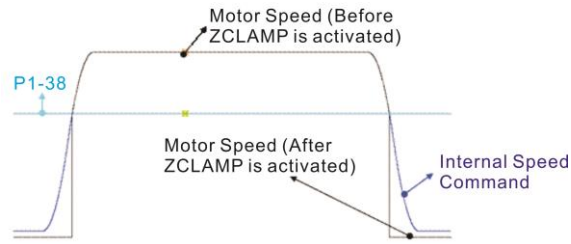

- Bit 11: Pulse inhibit function
 - 0: Disable NL / PL pulse input inhibit function. In PT mode, the external position pulse command will be input into the servo drive in any condition.
 - 1: Enable NL / PL pulse input inhibit function. In PT mode, if NL exists, the external NL pulse will be inhibited to input to the servo. PL pulse input will be accepted. In PT mode, if PL exists, the external PL pulse will be inhibited to input to the servo. NL pulse will be accepted.

Please note: In PT mode, if NL and PL both exist, both of them will be inhibited to input to the servo.
- Bit12: Lack phase detection
 - 0: Enable lack phase (AL022) detection
 - 1: Disable lack phase (AL022) detection
- Bit13: Encoder output error detection function
 - 0: Enable encoder output error (AL018) detection function
 - 1: Disable encoder output error (AL018) detection function
- Bit15: Friction compensation mode selection
 - 0: If the speed is slower than the value of P1-38, the compensation value remains.
 - 1: If the speed is slower than the value of P1-38, the compensation will become 0 according to the smoothing time of P1-63.

P2-66	GBIT2 Special-bit Register 2		Address: 0284H 0285H
Operational Interface :	Panel / Software	Communication	Related Section: -
Default :	0x0000		
Control Mode :	PT / PR / S		
Unit :	-		
Range :	0x0000 ~ 0x183F		
Data Size :	16-bit		
Format :	Hexadecimal		

Settings : Special-bit Register 2:

Bit7	Bit6	Bit5	Bit4	Bit3	Bit2	Bit1	Bit0
------	------	------	------	------	------	------	------

Bit15	Bit14	Bit13	Bit12	Bit11	Bit10	Bit9	Bit8
-------	-------	-------	-------	-------	-------	------	------

- Bit0 ~ Bit1: Reserved
- Bit2: Cancel latch function of low-voltage error
 0: Latch function of low-voltage error: the error will not be cleared automatically.
 1: Cancel latch function of low-voltage error: the error will be cleared automatically.
- Bit3: Reserved
- Bit4: Cancel the detection of AL044
 0: AL044 will occur
 1: AL044 will be ignored
- Bit5: Enable disconnection detection of linear scale (only when the full-closed loop control function is enabled)
 0: AL041 will be ignored
 1: AL041 will occur
- Bit6 ~ Bit8: Reserved
- Bit9: Set AL003 as ALM or WARN
 0: Set AL003 as WARN
 1: Set AL003 as ALM
- Bit10 ~ Bit11: Reserved
- Bit12: Set AL022 as ALM or WARN
 0: Set AL022 as WARN
 1: Set AL022 as ALM
- Bit13 ~ Bit15: Reserved

P2-67	JSL	The Stable Level of Inertia Estimation		Address: 0286H 0287H
	Operational Interface :	Panel / Software	Communication	Related Section: -
	Default :	1.5	15	
	Control Mode :	ALL		
	Unit :	1 times	0.1 times	
	Range :	0 ~ 200.0	0 ~ 2000	
	Data Size :	16-bit		
	Format :	One decimal	Decimal	
	Example :	1.5 = 1.5 times	15 = 1.5 times	

Settings : In semi-auto mode, if the value of inertia estimation is smaller than P2-67 and the status remains for a while, the system will regard the inertia estimation as completed.

P2-68	TEP	Switch of Following Error Compensation		Address: 0288H 0289H
	Operational Interface :	Panel / Software	Communication	Related Section: -
	Default :	0x00000000		
	Control Mode :	ALL		
	Unit :	-		
	Range :	0x00000000 ~ 0x00002101		
	Data Size :	32-bit		
	Format :	Hexadecimal		

Settings : X = 0: P1-36 > 1, following error compensation is disabled.

1: P1-36 > 1, following error compensation is enabled.

(The function is available after V1.036 sub00)

Y = 0: When E-CAM is engaged, JOG is not operable.

1: When E-CAM is engaged, JOG is operable.

(This function is not available now.)

Z = 0: DI.STP is triggered by rising edge.

1: DI.STP is action-level triggered.

(The function is available after V1.042 sub00)

U = 0: unit is 0.1 rpm in speed mode

1: unit is 0.01 rpm in speed mode

2: unit is 0.05 rpm in speed mode

P2-69●	ABS	Absolute Encoder Setting		Address: 028AH 028BH
	Operational Interface :	Panel / Software	Communication	Related Section: -
	Default :	0x0000		
	Control Mode :	ALL		
	Unit :	-		
	Range :	0x0000 ~ 0x0111		
	Data Size :	16-bit		

Format :	Hexadecimal
----------	-------------

Settings : Format: U Z Y X

X: Setup the operation mode

0: Incremental mode. Servo motor with absolute encoder can be operated as incremental motor.

1: Absolute mode. (This setting is only available for the servo motor with absolute encoder. When an incremental servo motor is connected, AL069 will occur.)

Y: Setup the pulse command when absolute position is lost

0: When AL060 or AL06A occurs, it cannot accept pulse command

1: When AL060 or AL06A occurs, it can accept pulse command

Z: Function setting when index coordinates overflow

0: Index coordinates is lost when overflows

1: Index coordinates will not overflow, but absolute coordinates (Fb_PUU)will not remain

U: Reserved

Note: This parameter is effective only after you cycle power to the servo drive. You can establish the absolute origin coordinates after completing setting this parameter.

P2-70	MRS	Read Data Format Selection		Address: 028CH 028DH
	Operational Interface :	Panel / Software	Communication	Related Section: N/A
	Default :	0x0000		
	Control Mode :	ALL		
	Unit :	-		
	Range :	0x0000 ~ 0x0007		
	Data Size :	16-bit		
	Format :	Hexadecimal		

Settings :

Bit7	Bit6	Bit5	Bit4	Bit3	Bit2	Bit1	Bit0
------	------	------	------	------	------	------	------

Bit15	Bit14	Bit13	Bit12	Bit11	Bit10	Bit9	Bit8
-------	-------	-------	-------	-------	-------	------	------

Bit 0: Data unit setting of digital input/output (DI/DO); 1: Pulse, 0: PUU

Bit 1: Communication data unit setting; 1: Pulse, 0: PUU

Bit 2: Overflow warning; 1: No overflow warning,
0: Overflow warning, AL289 (PUU),
AL062 (number of turns).

Bit 3 ~ Bit15: Reserved. Must be set to 0.

P2-71 ■	CAP	Absolute Position Homing	Address: 028EH 028FH
Operational Interface :	Panel / Software	Communication	Related Section: -
Default :	0x0000		
Control Mode :	ALL		
Unit :	-		
Range :	0 ~ 1		
Data Size :	16-bit		
Format :	Hexadecimal		

Settings : When P2-71 is set to 1, the current position will be set as home position. This function is the same as the digital input, ABSC. This function can be enabled only when parameter P2-08 is set to 271 and P2-69.X to 1.

P2-72	Reserved

P2-73	ALOP	E-Cam Alignment - Operation Setting	Address: 0292H 0293H
Operational Interface :	Panel / Software	Communication	Related Section: -
Default :	0x00000000		
Control Mode :	PR		
Unit :	-		
Range :	0x00000000 ~ 0x5F3F6F5F		
Data Size :	32-bit (format = DCBA : UZYX)		
Format :	Hexadecimal		

Settings : (This function is available in firmware version V1.038 sub26 and later models)

YX: Range of filter (0 ~ 95%)

UZ: Max. allowable correction rate (0 ~ 100%)

BA: PR number (0 ~ 63)

DC: Masking range setting (0 ~ 95%)

YX: Range of filter (%)

When digital input, ALGN is triggered, E-Cam alignment function is enabled. The system will detect the current E-Cam position. When the error between current E-Cam position and the last alignment position is less than this setting range (%), filter function is enabled. Otherwise, the system will use the new position to do the correction.

YX	00	01 ~ 05F
Function	Disabled	Error <= (1~YX) % : Enabled

*Using filter will allow the alignment action to be more stable and reduce position error caused by digital input noise.

UZ: Max. allowable correction rate (%)

When alignment correction is enabled, the limitation of max. correction rate (C) for each correction is defined as follows:

$$| C | <= (P5-84/P5-83) \times P2-73 \text{ UZ } \%$$

*When the alignment error is too big, to correct this error with one time may cause the motor vibration or overloading. Using this parameter will break the alignment correction into several smaller actions to smooth the correction action. But it may need more time to finish the alignment correction.

BA: PR number

After each alignment action is done, the shortage of pulse numbers of slave axis will be stored in this specified PR. Using this PR can compensate the slave position at appropriate timing.

*If BA is set to 0, it will not store the shortage of pulse numbers to PR.

DC: Masking range setting (%)

When digital input, ALGN is triggered, no another alignment action is allowed before the increasing pulse numbers of master axis exceeds the masking distance (M). After the increasing pulse numbers of master axis is greater than the distance (M) masking, the next alignment action is allowed.

The masking distance (M) is defined as follows:

$$M \geq (P5-84/P5-83) \times P2-73 \text{ DC } \%$$

*This masking function only allows increasing pulse input. This function will not work for decreasing pulse input.

P2-74	ALDY	E-Cam Alignment - DI Delay Time Compensation		Address: 0294H 0295H
	Operational Interface :	Panel / Software	Communication	Related Section: -
	Default :	0.000		
	Control Mode :	PR		

Unit :	ms with fraction down to usec
Range :	-25.000 ~ +25.000, with 3 fraction digits
Data Size :	16-bit
Format :	Decimal

Settings : (This function is available in firmware version V1.038 sub26 and later models)

This parameter is used to set for the compensation of delay time from digital input.

P2-75 ■	ALTG	E-Cam Alignment - Alignment Target Position		Address: 0296H 0297H
	Operational Interface :	Panel / Software	Communication	Related Section: -
	Default :	0		
	Control Mode :	PR		
	Unit :	The pulse unit of Master axis		
	Range :	0 ~ (P5-84 /P5-83)-1		
	Data Size :	32-bit		
	Format :	Decimal		

Settings : (This function is available in firmware version V1.038 sub26 and later models)

Note: When the input value is over the setting range, an error will occur. Then, the user cannot input the setting value.

Note: When a correct value is already set in P2-75 and does not exceed the setting range, if a change on P5-84 or P5-83 cause the value to exceed the setting range, this parameter will be reset to 0 automatically.

New value of P2-75 = 0 if P2-75 >=(P5-84 /P5-83)

P2-76 ■	ALCT	E-Cam Alignment - Source Setting		Address: 0298H 0299H
	Operational Interface :	Panel / Software	Communication	Related Section: -
	Default :	0x0000		
	Control Mode :	PR		
Unit :	-			

Range :	0x0000 ~ 0x6FF7
Data Size :	16-bit
Format :	Hexadecimal

Settings : (This function is available in firmware version V1.038 sub26 and later models)

Format=UZYX. The functions are listed below.

X: E-CAM Alignment Control

Bit	Bit 3	Bit 2	Bit 1	Bit 0
Function	Reserved	Phase Alignment in reverse direction	Trigger PR immediately	Enable Alignment
Description	-	Set 0 to disable the function. Set 1 to enable the function. This function is applicable to film delivery control of reverse rotary shear.	Set 1 to enable. When the alignment DI is triggered, the correcting error will be calculated and stored in PR specified by P2-73. If this bit is set to 1, trigger the PR immediately after DI activated, otherwise the user should trigger the PR manually or use P5-88.BA to call the PR when E-Cam disengaged.	Set 0 to disable. Set 1 to enable. If enable, the E-CAM alignment correction will be executed when DI.ALGN ON.

Y: Filter intensity

Y	0	1 ~ F
Function	Disabled	Average of 2^Z: Enabled

When the value of Y is increased, the change of correction is getting slow and it can expedite the performance of the filter function. This can avoid the disturbance caused by a sensor noise and a big error to be corrected within one time. Setting P2-76 too big will cause the alignment not able to work properly. The recommendatory value is 3.

UZ: Alignment path definition. Forward direction as setting reference here (0 ~ 100%)

0: Backward alignment only

30: Forward 30%, Backward 70%

50: Alignment with the shortest distance

80: Forward 80%, Backward 20%

>=100: Forward alignment only

P2-77	CMSK	E-Cam Master Axis – Pulse Masking Setting		Address: 029AH 029BH
	Operational Interface :	Panel / Software	Communication	Related Section: -

Default :	0x0000
Control Mode :	PR
Unit :	-
Range :	0x0000 ~ 0xFF7D
Data Size :	16-bit (format = U Z Y X)
Format :	Hexadecimal

Settings : (This function is available in firmware version V1.038 sub54 and later models)

X: Pulse masking function of master axis /

JOG function of master axis / INCH function of master axis

Y: Correction of lead command length for pulse masking

UZ: Pulse data when the master axis performs JOG or INCH function

Definition of Y: (Each bit is triggered by the rising edge)

Y3	Y2	Y1	Y0
-	Extra 1 Cycle	Write to ROM	CALC
-	Calculate the value of P5-87 and plus a cycle of a resolution of pulse command, i.e. (P5-84/P5-83).	Calculate the value of P5-87 and write the value of P5-87 into EEPROM at the same time to ensure the correct position of E-Cam after the servo drive is restarted (after switching power off and on).	Calculate the value of P5-87.

Y=0 → 1: Calculate the value of P5-87 correctly according to actual masking pulse number and additional virtual pulse number.

Y=0 → 2: Calculate the value of P5-87 correctly according to actual masking pulse number and additional virtual pulse number. Then, write the revised value of P5-87 into EEPROM to keep the same phase after the servo drive is restarted.

Y=0 → 7: Calculate the value of P5-87 correctly according to actual masking pulse number and additional virtual pulse number. But, the revised value of P5-87 will plus a value of (P5-84/P5-83) to make lead pulse wait for an E-Cam cycle.

For example:

Start masking → UZYX = 0x0001

JOG +3 Kpps → UZYX = 0x0302

JOG +20 Kpps → UZYX = 0x1402

JOG -32 Kpps → UZYX = 0x2003

INCH +255 PLS → UZYX = 0xFF04

INCH -18 PLS → UZYX = 0x1205

Complete and correct lead pulse → UZYX = 0x0020 (Write into EEPROM)

Disable this function → UZYX = 0x0000 (This step can be ignored)

P2-78	CMAP	E-Cam: Area Number #2 + (Polarity is Positive)		Address: 029CH 029DH
	Operational Interface :	Panel / Software	Communication	Related Section: N/A
	Default :	270		
	Control Mode :	PR		
	Unit :	degree (it becomes degree in firmware version V1.038 sub25 and later models)		
	Range :	0 ~ 360		
	Data Size :	16-bit		
	Format :	Decimal		

Settings : The relationship between DO:CAM_Area2 and parameter values is shown below:

P2-78 <= P2-79:

E-Cam degree	0°	~	P2-78	~	P2-79	~	360°
DO:CAM_AREA2	OFF	OFF	ON	ON	ON	OFF	OFF

P2-78 > P2-79:

E-Cam degree	0°	~	P2-79	~	P2-78	~	360°
DO:CAM_AREA2	ON	ON	OFF	OFF	OFF	ON	ON

When the E-Cam is disengaged, the status of digital output, CAM_AREA2 is always OFF.

P2-79	CMAP	E-Cam: Area Number #2 - (Polarity is Negative)		Address: 029EH 029FH
	Operational Interface :	Panel / Software	Communication	Related Section: -
	Default :	360		
	Control Mode :	PR		
	Unit :	degree (it becomes degree in firmware version V1.038 sub25 and later models)		
Range :	0 ~ 360			

Data Size :	16-bit
Format :	Decimal

Settings : The relationship between DO:CAM_Area2 and parameter values is shown below:

P2-78 <= P2-79:

E-Cam degree	0°	~	P2-78	~	P2-79	~	360°
DO:CAM_AREA2	OFF	OFF	ON	ON	ON	OFF	OFF

P2-78 > P2-79:

E-Cam degree	0°	~	P2-79	~	P2-78	~	360°
DO:CAM_AREA2	ON	ON	OFF	OFF	OFF	ON	ON

When the E-Cam is not engaged, the status of digital output, CAM_AREA2 is always OFF.

P2-80~ P2-93	Reserved
-------------------------	-----------------

P2-94	GBIT3	Special Bit Register 3	Address: 02BCH 02BDH
Operational Interface :	Panel / Software	Communication	Related Section: -
Default :	0x0000		
Control Mode :	PT / PR / S		
Unit :			
Range :	0x0000 ~ 0x7022		
Data Size :	16-bit		
Format :	Hexadecimal		

Settings : Special-bit Register 3:

Bit 7	Bit 6	Bit 5	Bit 4	Bit 3	Bit 2	Bit 1	Bit 0
-------	-------	-------	-------	-------	-------	-------	-------

Bit 15	Bit 14	Bit 13	Bit 12	Bit 11	Bit 10	Bit 9	Bit 8
--------	--------	--------	--------	--------	--------	-------	-------

B0 ~ B3 and B5 ~ 15: Reserved, please set to 0.

B4: New dynamic brake switch

0: Disable new dynamic brake

1: Enable new dynamic brake

Note: when you enable the new dynamic brake function, the new regenerative brake is enabled, which is the same as setting P2-65 bit 3 to 1.

P3-xx Communication Parameters

P3-00●	ADR	Address Setting		Address: 0300H 0301H
Operational Interface :	Panel / Software	Communication		Related Section: 9.2
Default :	0x007F			
Control Mode :	ALL			
Unit :	-			
Range :	0x0001 ~ 0x007F			
Data Size :	16-bit			
Format :	Hexadecimal			

Settings : The communication address setting is divided into Y, X (hexadecimal):

	0	0	Y	X
Range	-	-	0 ~ 7	0 ~ F

When using RS-232/RS-485 to communicate, one servo drive can only set one address. The duplicate address setting will cause abnormal communication.

This address represents the absolute address of the servo drive in communication network. It is also applicable to RS-232, RS-485, CANopen, and DMCENT.

When the communication address setting of MODBUS is set to 0xFF, the servo drive will automatically reply and receive data regardless of the address. However, P3-00 cannot be set to 0xFF.

P3-01	BRT	Transmission Speed		Address: 0302H 0303H
	Operational Interface :	Panel / Software	Communication	Related Section: 9.2
	Default :	0x3203 (for DMCNET models) 0x0203 (for other models)		
	Control Mode :	ALL		
	Unit :	bps		
	Range :	0x0000 ~ 0xF405		
	Data Size :	16-bit		
	Format :	Hexadecimal		

Settings : The setting of transmission speed is divided into Z, Y, X (hexadecimal):

	U	Z	Y	X
Communication Port	DMC	CAN / DMC	-	RS-232/485
Range	0 / 3	0 ~ 4	0	0 ~ 5

- Definition of X setting value
 - 0: 4800
 - 1: 9600
 - 2: 19200
 - 3: 38400
 - 4: 57600
 - 5: 115200
- Definition of Z setting value
 - 0: 125 Kbit/s
 - 1: 250 Kbit/s
 - 2: 500 Kbit/s
 - 3: 750 Kbit/s
 - 4: 1.0 Mbit/s
- Definition of U setting value
 - 0: Use Delta's controller, such as PLC and HMI
 - 3: Use Delta's motion card

- Note:
- 1) If this parameter is set via CAN, only Z can be set and the others remain.
 - 2) The communication speed of USB is 1.0 Mbit/s only and is unchangeable.

P3-02	PTL	Communication Protocol		Address: 0304H 0305H
	Operational Interface :	Panel / Software	Communication	Related Section: 9.2
	Default :	0x0006		
	Control Mode :	ALL		
	Unit :	-		
	Range :	0x0000 ~ 0x0008		
	Data Size :	16-bit		
	Format :	Hexadecimal		

Settings : The definition of the setting value is as the followings:

- 0: 7, N, 2 (MODBUS, ASCII)
- 1: 7, E, 1 (MODBUS, ASCII)
- 2: 7, O, 1 (MODBUS, ASCII)
- 3: 8, N, 2 (MODBUS, ASCII)
- 4: 8, E, 1 (MODBUS, ASCII)
- 5: 8, O, 1 (MODBUS, ASCII)
- 6: 8, N, 2 (MODBUS, RTU)
- 7: 8, E, 1 (MODBUS, RTU)
- 8: 8, O, 1 (MODBUS, RTU)

P3-03	FLT	MODBUS Communication Error Disposal		Address: 0306H 0307H
	Operational Interface :	Panel / Software	Communication	Related Section: 9.2
	Default :	0		
	Control Mode :	ALL		
	Unit :	-		
	Range :	0 ~ 1		
	Data Size :	16-bit		
	Format :	Hexadecimal		

Settings : The definition of the setting value is as the following:

- 0: Show warning and the motor keeps running
- 1: Show warning and the motor decelerates to stop (The deceleration time is set to parameter P5-03.B)

P3-04	CWD	Communication Timeout	Address: 0308H 0309H
Operational Interface :	Panel / Software	Communication	Related Section: 9.2
Default :	0		
Control Mode :	ALL		
Unit :	sec		
Range :	0 ~ 20		
Data Size :	16-bit		
Format :	DEC		
Settings :	If the setting value is not 0, enable communication timeout immediately. If it is set to 0, disable the function.		

P3-05	CMM	Communication Mechanism	Address: 030AH 030BH
Operational Interface :	Panel / Software	Communication	Related Section: 9.2
Default :	0x0000		
Control Mode :	ALL		
Unit :	-		
Range :	0x0000 ~ 0x0001		
Data Size :	16-bit		
Format :	Hexadecimal		
Settings :	Communication port can select one or more than one communications. <ul style="list-style-type: none"> ● Communication Interface <ul style="list-style-type: none"> 0: RS232 (only applicable to A2-L and A2-M models) 1: RS485 (only applicable to A2-L, A2-M, and A2-LN models) 		

P3-06	SDI	Control Switch of Digital Input (DI)		Address: 030CH 030DH
	Operational Interface :	Panel / Software	Communication	Related Section: 9.2
	Default :	0x0000		
	Control Mode :	ALL		
	Unit :	-		
	Range :	0x0000 ~ 0x3FFF		
	Data Size :	16-bit		
	Format :	Hexadecimal		

Settings : The source of DI controls the switch.
 Each bit of this parameter decides one input source of DI signal:
 Bit0 ~ Bit7 correspond to DI1 ~ DI8.
 Bit8 ~ Bit13 correspond to extended DI EDI9 ~ EDI14;
 The setting of bit is as the followings:
 0: The input status is controlled by the external hardware.
 1: The input status is controlled by P4-07.
 For the functional planning of digital input, please refer to:
 DI1 ~ DI8: P2-10 ~ P2-17
 EDI9 ~ EDI14: P2-36 ~ P2-41

P3-07	CDT	Communication Response Delay Time		Address: 030EH 030FH
	Operational Interface :	Panel / Software	Communication	Related Section: 9.2
	Default :	0		
	Control Mode :	ALL		
	Unit :	0.5 ms		
	Range :	0 ~ 1000		
	Data Size :	16-bit		
	Format :	Decimal		

Settings : Delay the time of communication response from servo drive to controller.

P3-08	Reserved
--------------	-----------------

P3-09	SYC	CANopen / DMCNET Synchronize Setting	Address: 0312H 0313H
Operational Interface :	Panel / Software	Communication	Related Section: 9.2
Default :	0x3511 (for DMCNET models) 0x5055 (for other models)		
Control Mode :	CANopen / DMC		
Unit :	-		
Range :	Shown as below		
Data Size :	16-bit		
Format :	Hexadecimal		

Settings : The synchronous setting of CANopen / DMCNET is divided into E, T, D and M (hexadecimal):

Item	E	T	D	M
Function	Range of Synchronous error	Target Value	Deadband	Adjusting amount
Range	1 ~ 9	0 ~ 9	0 ~ F	1 ~ F

The slave of CANopen / DMCNET synchronizes with the master via SYNC. See as the followings:

- M: If the slave needs to synchronize with the master, correct the clock is a must. This parameter sets the maximum correction value per time. (Unit: usec)
- D: Set the size of deadband (Unit: usec). If the deviation between the SYNC reaching time and the target value does not exceed the deadband, correction is no need.
- T: SYNC arrival time. The standard value is 500usec but it might be different from the target value. Thus, the buffer is necessary.
Target value = 400 + 10 x T.
For instance, if T=5, the target value will be 450.
- E: If the deviation between SYNC reaching time and the target value is smaller than the range, it means the synchronization is successful. (Unit: 10 usec)

P3-10	CANEN	CANopen / DMCNET Protocol Setting		Address: 0314H 0315H
	Operational Interface :	Panel / Software	Communication	Related Section: Section 9.2
	Default :	0x0001 (for DMCNET models) 0x0000 (for other models)		
	Control Mode :	CANopen / DMC		
	Unit :	-		
	Range :	Shown as below		
	Data Size :	16-bit		
	Format :	Hexadecimal		

Settings : CANopen / DMCNET synchronization setting is divided into X, Y, Z, U (hexadecimal):

Item	U	Z	Y	X
Function	If PDO alarm will be cleared automatically	Reserved	If motor will servo off when CAN Bus / DMCNET error occurs	Reserved
Range	0 ~ 1	0 ~ F	0 ~ 1	0 ~ 1

Definition:

X: Reserved

Y: 0: The motor keeps running when communication error (AL170) occurs (only functions in 0B mode of CANopen);

1: The motor servo Off when communication error (AL180) occurs.

Z: Reserved

U: 0: If PDO error occurs, it must be cleared by Alarm Rest

1: If PDO error occurs, it will be cleared automatically.

Note:

For A2-M, Y bit is valid while X bit is invalid.

For A2-F, it is suggested to set X to 1.

P3-11	Reserved
--------------	-----------------

P3-12	QSTPO	CANopen / DMCNET Support Setting		Address: 0318H 0319H
	Operational Interface :	Panel / Software	Communication	Related Section: Section 9.2
	Default :	0x0000		
	Control Mode :	CANopen / DMC		
	Unit :	-		
	Range :	0x0000 ~ 0x0111		
	Data Size :	16-bit		
	Format :	Hexadecimal		

Settings :

Item	U	Z	Y	X
Function	None	Load in the CANopen / DMCNET value	If the motor will enter Quick Stop mode when in auto protection.	If OD-6040 supports Quick Stop
Range	None	0 ~ 1	0 ~ 1	0 ~ 1

Aiming to CANopen Quick Stop mode, we have X and Y setting (Hexadecimal.) which is showed as below. It is only suitable in CAN mode: 0xb mode selection (P1-01 = b).

X: Trigger Servo ON sequence and Quick Stop support setting

X = 0: Servo On the servo drive by turning On OD-0x6040 Bit 3 (Enable Operation). OD-0x6040 Bit 2 enters Quick Stop mode is not supported.

X = 1: The servo drive can be Servo ON only when OD-0x6040 Bit 0, Bit 1, Bit 3 are ON. And will enter Quick Stop mode via OD-0x6040 Bit 2 (Quick Stop)

Y: When warning alarms (positive / negative limit, communication error, under voltage, abnormal fan) occur, it can determine if Quick Stop mode can be triggered.

Y = 0: When warning alarms occur, if motor decelerates to stop because of auto protection function, it will not enter Quick Stop mode. Users only need to troubleshoot the alarm and clear the alarm message from the servo drive, the servo drive status will resume.

Y = 1: When warning alarms occur, if motor decelerates to stop because of auto protection function, OD-0x6040 will enter Quick Stop mode. Users have to issue Fault Reset (Bit 1 = 1 → 0) to OD-0x6040 Bit to troubleshoot the alarm and clear the alarm message from the servo drive, and the servo drive status will resume.

The following table shows P parameters and its corresponding

CANopen OD or DMCNET parameter. The setting of Z (Hexadecimal) can determine if it should be modified. This function is applicable in CAN mode: 0xB or 0xC (P1-01 = b or c) or DMC mode: 0xB (P1-01 = b).

Z: Determine if the value of default parameters will overlap parameters from P groups.

Z = 0: When re-servo on the servo drive or reset the communication, P parameters that mentioned in the following table will be overlapped by the value of default parameters in CANopen / DMCNET.

Z = 1: When re-servo on the servo drive or reset the communication, P parameters that mentioned in the following table will keep the value that before power off.

CANopen mode:

Related variables during initialization	P3-12.Z = 0	P3-12.Z = 1	Note
P1-32	0x0010	EEPROM	
P2-35	3840000	EEPROM	
P1-47	10	EEPROM	
P1-49	0	EEPROM	
P1-38	100	EEPROM	
Home offset	0	EEPROM	Used in HM mode
Torque slope	200	EEPROM	Used in PT mode
P1-44	1	EEPROM	
P1-45	1	EEPROM	

DMCNET mode:

Related variables during initialization	P3-12.Z = 0	P3-12.Z = 1	Note
P1-32	0x0010	EEPROM	
P2-35	3840000	EEPROM	
P1-47	100	EEPROM	
P1-49	0	EEPROM	
P1-38	100	EEPROM	
Home offset	0	Undefined	Used in HM mode
Acc	200	Undefined	Used in PV, PP mode
Dec	200	Undefined	Used in PV, PP mode
Torque	200	Undefined	Used in PT mode
P1-44	1	EEPROM	
P1-45	1	EEPROM	

Methods that save parameters in EEPROM (even when the power is off):

SDO: When setting parameters, parameters will be stored in EEPROM.

Note: In CANopen mode, when using the function of OD 1010 Store Parameter and P3-12.Z = 0, the default value will be different from the value shown above. Please refer to CANopen Standard for further information.

P4-xx Diagnosis Parameters

P4-00★	ASH1	Fault Record (N)	Address: 0400H 0401H
	Operational Interface :	Panel / Software	Communication
	Default :	0x00000000	
	Control Mode :	ALL	
	Unit :	-	
	Range :	-	
	Data Size :	32-bit	
	Format :	Hexadecimal	
	Settings :	The last abnormal status record Low word: LXXXX: display ALM number High word: hYYYY: display the corresponding CANopen / DMCNET error code.	

P4-01★	ASH2	Fault Record (N-1)	Address: 0402H 0403H
	Operational Interface :	Panel / Software	Communication
	Default :	0x00000000	
	Control Mode :	ALL	
	Unit :	-	
	Range :	-	
	Data Size :	32-bit	
	Format :	Hexadecimal	
	Settings :	The last second abnormal status record Low word: LXXXX: display ALM number High word: hYYYY: display the corresponding CANopen / DMCNET error code	

P4-02★	ASH3	Fault Record (N-2)	Address: 0404H 0405H
	Operational Interface :	Panel / Software	Communication
	Default :	0x00000000	
	Control Mode :	ALL	
	Unit :	-	
	Range :	-	
	Data Size :	32-bit	
	Format :	Hexadecimal	
	Settings :	The last third abnormal status record Low word: LXXXX: display ALM number High word: hYYYY: display the corresponding CANopen / DMCNET error code	

P4-03★	ASH4	Fault Record (N-3)	Address: 0406H 0407H
	Operational Interface :	Panel / Software	Communication
	Default :	0x00000000	
	Control Mode :	ALL	
	Unit :	-	
	Range :	-	
	Data Size :	32-bit	
	Format :	Hexadecimal	
	Settings :	The last fourth abnormal status record Low word: LXXXX: display ALM number High word: hYYYY: display the corresponding CANopen / DMCNET error code	

P4-04★	ASH5	Fault Record (N-4)	Address: 0408H 0409H
Operational Interface :	Panel / Software	Communication	Related Section: 4.4.1
Default :	0x00000000		
Control Mode :	ALL		
Unit :	-		
Range :	-		
Data Size :	32-bit		
Format :	Hexadecimal		
Settings :	The last fifth abnormal status record Low word: LXXXX: display ALM number High word: hYYYY: display the corresponding CANopen / DMCNET error code		

P4-05	JOG	Servo Motor Jog Control	Address: 040AH 040BH
Operational Interface :	Panel / Software	Communication	Related Section: 4.4.2
Default :	20		
Control Mode :	ALL		
Unit :	r/min		
Range :	0 ~ 5000		
Data Size :	16-bit		
Format :	Decimal		
Settings :	Three control methods are as follows: <ol style="list-style-type: none"> 1. Operation Test After the JOG speed is set by P4-05 via panel, the panel will display the symbol of JOG. Pressing the UP Key can control JOG operation in positive direction, and pressing the DOWN Key can control negative direction. Stop pressing to stop the JOG operation. If there is any error in this setting, then the motor cannot operate. The maximum JOG speed is the maximum speed of the servo motor. 2. DI Control If the DI is set to JOGU and JOGD (refer to table 8.1), then the JOG operation in positive or negative direction can be controlled via this DI. 		

3. Communication Control
 1 ~ 5000: JOG speed
 4998: JOG operation in positive direction
 4999: JOG operation in negative direction
 0: Stop operation

Note: When writing via communication, if the frequency is high, please set P2-30 to 5.

P4-06■	FOT	Digital Output Register (Readable and Writable)	Address: 040CH 040DH
Operational Interface :	Panel / Software	Communication	Related Section: 4.4.3
Default :	0x0000		
Control Mode :	ALL		
Unit :	-		
Range :	0x0000 ~ 0x00FF		
Data Size :	16-bit		
Format :	Hexadecimal		

Settings : bit 00: correspond to DO code=0x30
 bit 01: correspond to DO code=0x31
 bit 02: correspond to DO code=0x32
 bit 03: correspond to DO code=0x33
 bit 04: correspond to DO code=0x34
 bit 05: correspond to DO code=0x35
 bit 06: correspond to DO code=0x36
 bit 07: correspond to DO code=0x37
 bit 08: correspond to DO code=0x38
 bit 09: correspond to DO code=0x39
 bit 10: correspond to DO code=0x3A
 bit 11: correspond to DO code=0x3B
 bit 12: correspond to DO code=0x3C
 bit 13: correspond to DO code=0x3D
 bit 14: correspond to DO code=0x3E
 bit 15: correspond to DO code=0x3F

If P2-18 is set to 0x0130, then the DO#1 is bit 0 status of P4-06, and so forth.

DO Code (0x30 ~ 0x3F) can be set via communication DO, and then write into P4-06.

P4-07	ITST	Multi-function of Digital Input		Address: 040EH 040FH
	Operational Interface :	Panel / Software	Communication	Related Section: Section 4.4.4 Section 9.2
	Default :	0x0000		
	Control Mode :	ALL		
	Unit :	-		
	Range :	0x0000 ~ 0x3FFF		
	Data Size :	16-bit		
	Format :	Hexadecimal		

Settings : The DI input signal can come from external terminal (DI1 ~ DI8; EDI9 ~ EDI14) or software SDI1 ~ 14 (Bit 0 ~ 13 of corresponding parameter P4-07) and is determined by P3-06. The corresponding bit of P3-06 is 1, which means the source is software SDI (P4-07). If the corresponding bit is 0, then the source is hardware DI. See the following graph:

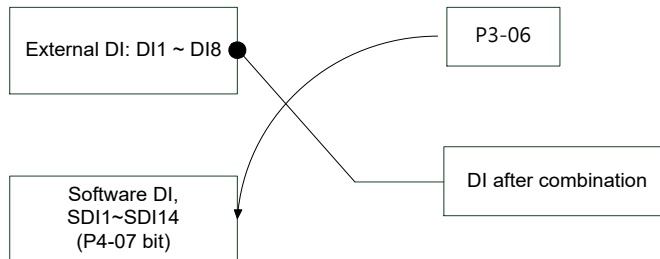

Read parameters: shows the DI status after combination

Write parameters: writes the software SDI status

(This function is the same whether using the panel or communication to set the parameter.)

For example:

The value of reading P4-07 is 0x0011, which means DI1 and DI5 is ON after combination.

The value of writing P4-07 is 0x0011, which means software SDI1 and SDI5 is ON.

Please refer to P2-10 ~ P2-17 for the function program of digital input pin DI (DI1 ~ DI8) and P2-36 ~ P2-41 for extended DI (EDI9 ~ EDI14).

P4-08★	PKEY	Input Status of the Drive Keypad (Read-only)	Address: 0410H 0411H	
	Operational Interface :	Panel / Software	Communication	Related Section: -
	Default :	-		
	Control Mode :	ALL		
	Unit :	-		
	Range :	(read-only)		
	Data Size :	16-bit		
	Format :	Hexadecimal		
	Settings :	The aim is to check if the five keys, MODE, UP, DOWN, SHIFT, and SET, can work normally. This parameter is also used to check if the Keys are all functional when producing servo drives.		

P4-09★	MOT	Digital Output Status (Read-only)	Address: 0412H 0413H	
	Operational Interface :	Panel / Software	Communication	Related Section: 4.4.5
	Default :	-		
	Control Mode :	ALL		
	Unit :	-		
	Range :	0x0000 ~ 0x001F		
	Data Size :	16-bit		
	Format :	Hexadecimal		
	Settings :	Note: There is no difference when you read the status through the panel or communication.		

P4-10■	CEN	Adjustment Selection	Address: 0414H 0415H	
	Operational Interface :	Panel / Software	Communication	Related Section: -
	Default :	0		
	Control Mode :	ALL		
	Unit :	-		

Range :	0 ~ 6
Data Size :	16-bit
Format :	Decimal

- Settings :
- 0: reserved
 - 1: Execute the calibration of analog speed input offset
 - 2: Execute the calibration of analog torque input offset
 - 3: Execute the calibration of current detector (V phase) hardware offset
 - 4: Execute the calibration of current detector (W phase) hardware offset
 - 5: Execute the calibration of 1 ~ 4 hardware offset
 - 6: Execute the calibration of IGBT ADC

Note: The calibration function needs to be enabled by P2-08. When calibration, the external wiring which connects to analog speed or torque needs to be removed completely and must be in Servo Off status.

P4-11	SOF1	Analog Speed Input Offset Adjustment 1		Address: 0416H 0417H
	Operational Interface :	Panel / Software	Communication	Related Section: -
	Default :	Factory default		
	Control Mode :	ALL		
	Unit :	-		
	Range :	0 ~ 32767		
	Data Size :	16-bit		
	Format :	Decimal		

Settings : Manually calibrate the hardware offset. The calibration function needs to be enabled by P2-08. It is not suggested to adjust the auxiliary calibration function. This parameter cannot be reset.

P4-12	SOF2	Analog Speed Input Offset Adjustment 2		Address: 0418H 0419H
Operational Interface :	Panel / Software	Communication		Related Section: -
Default :	Factory default			
Control Mode :	ALL			
Unit :	-			
Range :	0 ~ 32767			
Data Size :	16-bit			
Format :	Decimal			

Settings : Manually calibrate the hardware offset. The calibration function needs to be enabled by P2-08. It is not suggested to adjust the auxiliary calibration function. This parameter cannot be reset.

P4-13	TOF1	Analog Torque Input Offset Adjustment 1		Address: 041AH 041BH
Operational Interface :	Panel / Software	Communication		Related Section: -
Default :	Factory default			
Control Mode :	ALL			
Unit :	-			
Range :	0 ~ 32767			
Data Size :	16-bit			
Format :	Decimal			

Settings : Manually calibrate the hardware offset. The calibration function needs to be enabled by P2-08. It is not suggested to adjust the auxiliary calibration function. This parameter cannot be reset.

P4-14	TOF2	Analog Torque Input Offset Adjustment 2		Address: 041CH 041DH
Operational Interface :	Panel / Software	Communication		Related Section: -
Default :	Factory default			
Control Mode :	ALL			
Unit :	-			
Range :	0 ~ 32767			
Data Size :	16-bit			
Format :	Decimal			

Settings : Manually calibrate the hardware offset. The calibration function needs to be enabled by P2-08. It is not suggested to adjust the auxiliary calibration function. This parameter cannot be reset.

P4-15	COF1	Current Detector (V1 Phase) Offset Adjustment		Address: 041EH 041FH
Operational Interface :	Panel / Software	Communication		Related Section: -
Default :	Factory default			
Control Mode :	ALL			
Unit :	-			
Range :	0 ~ 32767			
Data Size :	16-bit			
Format :	Decimal			

Settings : Manually calibrate the hardware offset. The calibration function needs to be enabled by P2-08. It is not suggested to adjust the auxiliary calibration function. This parameter cannot be reset.

P4-16	COF2	Current Detector (V2 Phase) Offset Adjustment		Address: 0420H 0421H
	Operational Interface :	Panel / Software	Communication	Related Section: -
	Default :	Factory default		
	Control Mode :	ALL		
	Unit :	-		
	Range :	0 ~ 32767		
	Data Size :	16-bit		
	Format :	Decimal		

Settings : Manually calibrate the hardware offset. The calibration function needs to be enabled by P2-08. It is not suggested to adjust the auxiliary calibration function. This parameter cannot be reset.

P4-17	COF3	Current Detector (W1 Phase) Offset Adjustment		Address: 0422H 0423H
	Operational Interface :	Panel / Software	Communication	Related Section: -
	Default :	Factory default		
	Control Mode :	ALL		
	Unit :	-		
	Range :	0 ~ 32767		
	Data Size :	16-bit		
	Format :	Decimal		

Settings : Manually calibrate the hardware offset. The calibration function needs to be enabled by P2-08. It is not suggested to adjust the auxiliary calibration function. This parameter cannot be reset.

P4-18	COF4	Current Detector (W2 Phase) Offset Adjustment	Address: 0424H 0425H
	Operational Interface :	Panel / Software	Communication
	Default :	Factory default	
	Control Mode :	ALL	
	Unit :	-	
	Range :	0 ~ 32767	
	Data Size :	16-bit	
	Format :	Decimal	

Settings : Manually calibrate the hardware offset. The calibration function needs to be enabled by P2-08. It is not suggested to adjust the auxiliary calibration function. This parameter cannot be reset.

P4-19	TIGB	IGBT NTC Adjustment Detection Level (cannot reset)	Address: 0426H 0427H
	Operational Interface :	Panel / Software	Communication
	Default :	Factory default	
	Control Mode :	ALL	
	Unit :	-	
	Range :	1 ~ 4	
	Data Size :	16-bit	
	Format :	Decimal	

Settings : Please cool down the drive to 25 Celsius degree when adjusting. The calibration function needs to be enabled by P2-08.

P4-20	DOF1	Offset Adjustment Value of Analog Monitor Output (Ch1)	Address: 0428H 0429H
	Operational Interface :	Panel / Software Communication	Related Section: 6.4.4
	Default :	0	
	Control Mode :	ALL	
	Unit :	mV	
	Range :	-800 ~ 800	
	Data Size :	16-bit	
	Format :	Decimal	
	Settings : Offset calibration value (cannot reset). The calibration function needs to be enabled by P2-08.		

P4-21	DOF2	Offset Adjustment Value of Analog Monitor Output (Ch2)	Address: 042AH 042BH
	Operational Interface :	Panel / Software Communication	Related Section: 6.4.4
	Default :	0	
	Control Mode :	ALL	
	Unit :	mV	
	Range :	-800 ~ 800	
	Data Size :	16-bit	
	Format :	Decimal	
	Settings : Offset calibration value (cannot reset). The calibration function needs to be enabled by P2-08.		

P4-22	SAO	Analog Speed Input OFFSET	Address: 042CH 042DH
	Operational Interface :	Panel / Software Communication	Related Section: -
	Default :	0	
	Control Mode :	S	
	Unit :	mV	

Range :	-5000 ~ 5000
Data Size :	16-bit
Format :	Decimal

Settings : Users manually adjust the offset value.

P4-23	TAO	Analog Torque Input OFFSET		Address: 042EH 042FH
	Operational Interface :	Panel / Software	Communication	Related Section: -
	Default :	0		
	Control Mode :	T		
	Unit :	mV		
	Range :	-5000 ~ 5000		
	Data Size :	16-bit		
	Format :	Decimal		

Settings : Users manually adjust the offset value.

220V Series

P4-24	LVL	Level of Under voltage Error		Address: 0430H 0431H
	Operational Interface :	Panel / Software	Communication	Related Section: -
	Default :	160		
	Control Mode :	ALL		
	Unit :	V (rms)		
	Range :	140 ~ 190		
	Data Size :	16-bit		
	Format :	Decimal		

Settings : When the voltage of DC BUS is lower than $P4-24 * \sqrt{2}$, the under voltage alarm occurs.

400V Series

P4-24	LVL	Level of Under voltage Error	Address: 0430H 0431H
Operational Interface :	Panel / Software	Communication	Related Section: -
Default :	320		
Control Mode :	ALL		
Unit :	V (rms)		
Range :	140 ~ 380		
Data Size :	16-bit		
Format :	Decimal		

Settings : When the voltage of DC BUS is lower than $P4-24 * \sqrt{2}$, the under voltage alarm occurs.

P5-xx Motion Setting Parameters

P5-00 ~ P5-02	Reserved
----------------------	----------

P5-03	PDEC	Deceleration Time of Auto Protection	Address: 0506H 0507H
Operational Interface :		Panel / Software	Communication
Default :		0XEEFEEFF	
Control Mode :		ALL	
Unit :		-	
Range :		0x00000000 ~ 0xFFFFFFFF	
Data Size :		32-bit	
Format :		Hexadecimal	

Related Section: -

Settings : The parameter setting is divided into D, C, B, A, W, Z, Y, X (hexadecimal), including:

1. The deceleration time when activating the auto-protection function: OVF (DO.0x11, position command / feedback overflows), CTO (communication timeout AL020), SPL, SNL, PL, NL
2. Deceleration time of Stop Command: STP

Item	D	C	B	A	W	Z	Y	X
Function	STP	PFQS	CTO	OVF	SNL	SPL	NL	PL
Range	0 ~ F	0 ~ F	0 ~ F	0 ~ F	0 ~ F	0 ~ F	0 ~ F	0 ~ F

0 ~ F is used to indexing the deceleration time of P5-20 ~ P5-35.

For example: If X is set to A, then the deceleration time of PL is determined by P5-30.

P5-04	HMOV	Homing Mode		Address: 0508H 0509H
	Operational Interface :	Panel / Software	Communication	Related Section: -
	Default :	0x0000		
	Control Mode :	PR		
	Unit :	-		
	Range :	0x0000 ~ 0x0128		
	Data Size :	16-bit		
	Format :	Hexadecimal		

Settings :

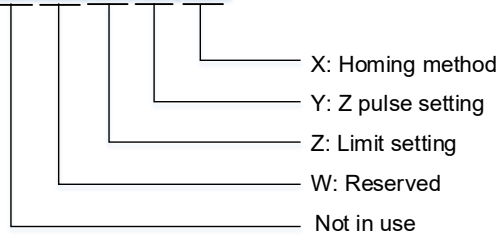

The definition of the setting value is as the followings:

W	Z	Y	X
Reserved	Limit Setting	Z pulse Setting	Homing Method
-	0 ~ 1	0 ~ 2	0 ~ 8
		Y = 0: Stop and return to Z pulse	X = 0: Homing in forward direction and regard PL as the homing origin.
		Y = 1: Go forward to Z pulse	X = 1: Homing in reverse direction and regard NL as the homing origin.
		Y = 2: Do not look for Z pulse	X = 2: Homing in forward direction ORGP: OFF > ON, as the homing origin
	When encounter limit: Z = 0: shows error Z = 1: rotates backwards		X = 3: Homing in reverse direction ORGP: OFF > ON, as the homing origin
			X = 4: Look for Z pulse in forward direction and regard it as the homing origin
			X = 5: Look for Z pulse in reverse direction and regard it as the homing origin
			X = 6: Homing in forward direction ORGP: ON > OFF, as the homing origin
			X = 7: Homing in reverse direction ORGP: ON > OFF, as the homing origin

W	Z	Y	X
Reserved	Limit Setting	Z pulse Setting	Homing Method
-	0 ~ 1	0 ~ 2	0 ~ 8
	When encounter limit: Z = 0: shows error Z = 1: rotates backwards	Y = 0: Stop and return to Z pulse	X = 7: Homing in reverse direction ORGP: ON > OFF, as the homing origin
		Y = 1: Go forward to Z pulse	X = 8: directly define the current position as the origin
		Y = 2: Do not look for Z pulse	X = 9: Regard the Hard Stop as the original point in forward direction
		Y = 0: Return to Z pulse Y = 1: Do not look for Z pulse	X = A: Regard the Hard Stop as the original point in reverse direction

P5-05	HSPD1	1st Speed Setting of High Speed Homing	Address: 050AH 050BH
	Operational Interface :	Panel / Software	Communication
	Default :	100.0	1000
	Control Mode :	PR (This has to be set with P5-04)	
	Unit :	1 r/min	0.1 r/min
	Range :	0.1 ~ 2000.0	1 ~ 20000
	Data Size :	16-bit	
	Format :	Decimal	
	Example :	1.5 = 1.5 r/min	15 = 1.5 r/min

Related Section: -

Settings : The 1st speed of high speed homing

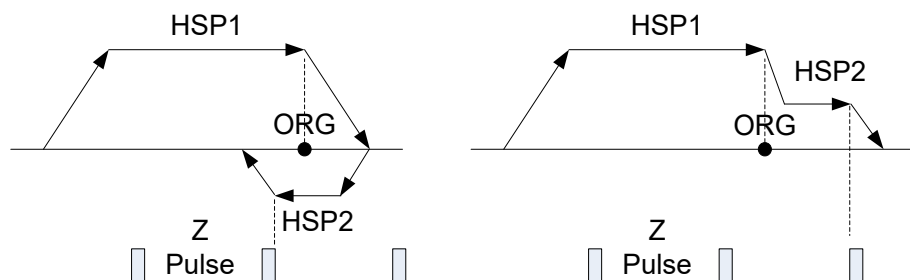

P5-06	HSPD2	2 nd Speed Setting of Low Speed Homing		Address: 050CH 050DH
Operational Interface :	Panel / Software	Communication		Related Section: -
Default :	20.0	200		
Control Mode :	PR (This has to be set with P5-04)			
Unit :	1 r/min	0.1 r/min		
Range :	0.1 ~ 500.0	1 ~ 5000		
Data Size :	16-bit			
Format :	Decimal			
Example :	1.5 = 1.5 r/min	15 = 1.5 r/min		

Settings : The 2nd speed setting of low speed homing

P5-07 ■	PRCM	Trigger Position Command (PR mode only)		Address: 050EH 050FH
Operational Interface :	Panel / Software	Communication		Related Section: -
Default :	0			
Control Mode :	PR			
Unit :	-			
Range :	0 ~ 1000			
Data Size :	16-bit			
Format :	Decimal			

Settings : Set P5-07 to 0 to start homing

Set P5-07 to 1 ~ 63 to execute PR procedure which is the same as DI.CTRG+POS_n

It is prohibited to set P5-07 to 64 ~ 9999 (The value exceeds the valid range)

Set P5-07 to 1000 to execute Stop Command which is the same as DI.STP

When reading P5-07:

If the command is incomplete, the drive will read the current command.

If the command is completed, the drive will read the current command +10000.

If the command is completed and DO.TPOS is ON, reach the motor position, the drive will read the current command +20000.

When PR is triggered by DI, the reading value is the same

For example:

Set P5-07 to 3, PR#3 will be triggered.

If the reading value is 3, it means PR #3 is incomplete.

If the reading value is 10003, it means PR#3 is issued completely, but the motor has not reached the target position yet.

If the reading value is 20003, it means PR#3 is issued completely and the motor has reached the target position.

P5-08	SWLP	Forward Software Limit		Address: 0510H 0511H
	Operational Interface :	Panel / Software	Communication	Related Section: -
	Default :	2147483647		
	Control Mode :	PR		
	Unit :	PUU		
	Range :	-2147483648 ~ +2147483647		
	Data Size :	32-bit		
	Format :	Decimal		

Settings : In PR mode, if the motor rotates in forward direction and its command position exceeds the setting value of P5-08, it will trigger AL283.

P5-09	SWLN	Reverse Software Limit		Address: 0512H 0513H
	Operational Interface :	Panel / Software	Communication	Related Section: -
	Default :	-2147483648		
	Control Mode :	PR		
	Unit :	PUU		
	Range :	-2147483648 ~ +2147483647		
	Data Size :	32-bit		
	Format :	Decimal		

Settings : In PR mode, if the motor rotates in reverse direction and its command position exceeds the setting value of P5-09, it will trigger AL285.

P5-10★	AYSZ	Data Array - Data Size		Address: 0514H 0515H
	Operational Interface :	Panel / Software	Communication	Related Section: 7.2
	Default :	-		
	Control Mode :	ALL		
	Unit :	-		
	Range :	Read-only		
	Data Size :	16-bit		
	Format :	Decimal		

Settings : Data size (N x 32 bits) means size N of data array.

P5-11■	AYID	Data Array - Address of Reading / Writing		Address: 0516H 0517H
	Operational Interface :	Panel / Software	Communication	Related Section: 7.2
	Default :	0		
	Control Mode :	ALL		
	Unit :	-		
	Range :	0 ~ (value set by P5-10 minus 1)		
	Data Size :	16-bit		
	Format :	Decimal		

Settings : The address of specified data when reading or writing data array.

P5-12■	AYD0	Data Array - Window #1 for Reading / Writing		Address: 0518H 0519H
	Operational Interface :	Panel / Software	Communication	Related Section: 7.2
	Default :	0		
	Control Mode :	ALL		
Unit :	-			

Range :	-2147483648 ~ +2147483647
Data Size :	32-bit
Format :	Decimal

Settings : Window #1 (Array[P5-11++])

When reading the parameter via panel, the value set by P5-11 will not add 1, but the others will.

P5-13	AYD1	Data Array - Window #2 for Reading / Writing		Address: 051AH 051BH
	Operational Interface :	Panel / Software	Communication	Related Section: 7.2
	Default :	0		
	Control Mode :	ALL		
	Unit :	-		
	Range :	-2147483648 ~ +2147483647		
	Data Size :	32-bit		
	Format :	Decimal		

Settings : Window #2 (Array[P5-11++])

When reading and writing the parameter via panel or communication, the value set by P5-11 will add 1. Panel is write-protected.

P5-14	Reserved
--------------	-----------------

P5-15	PMEM	PATH#1 ~ PATH#2 No Data Retained Setting		Address: 051EH 051FH
Operational Interface :	Panel / Software	Communication		Related Section: -
Default :	0x00000			
Control Mode :	ALL			
Unit :	-			
Range :	0x0000 ~ 0x0011			
Data Size :	16-bit			
Format :	Hexadecimal			

Settings : The parameter is divided into 00YX:

X=0: PATH#1 Data retained

X=1: PATH#1 No data retained

Y=0: PATH#2 Data retained

Y=1: PATH#2 No data retained

Others are reserved

Users can continuously write the new position into the drive through communication by P5-05.

P5-16	AXEN	Axis Position - Motor Encoder		Address: 0520H 0521H
Operational Interface :	Panel / Software	Communication		Related Section: 7.3
Default :	0			
Control Mode :	ALL			
Unit :	PUU (User position unit)			
Range :	-2147483648 ~ +2147483647			
Data Size :	32-bit			
Format :	Decimal			

Settings : Read: The feedback position of the motor encoder, which is the monitor various V000 + the offset value. (This function is supported after firmware version V1.015)

Write: Any value can be written into the parameter and will neither change V000 nor influence the positioning coordinate system. It is only for observation when adjusting the offset value.

P5-17	AXAU	Axis Position - Auxiliary Encoder		Address: 0522H 0523H
	Operational Interface :	Panel / Software	Communication	Related Section: 7.3
	Default :	0		
	Control Mode :	ALL		
	Unit :	Pulse number		
	Range :	-2147483648 ~ +2147483647		
	Data Size :	32-bit		
	Format :	Decimal		

Settings : Sends back: pulse counts of the auxiliary encoder (linear scale)

P5-18	AXPC	Axis Position - Pulse Command		Address: 0524H 0525H
	Operational Interface :	Panel / Software	Communication	Related Section: 7.3
	Default :	0		
	Control Mode :	ALL		
	Unit :	Pulse number		
	Range :	-2147483648 ~ +2147483647		
	Data Size :	32-bit		
	Format :	Decimal		

Settings : Sends back: pulse counts of pulse command

P5-19	TBS	E-Cam Curve Scaling		Address: 0526H 0527H
	Operational Interface :	Panel / Software	Communication	Related Section: -
Default :	1.000000			
Control Mode :	PR			
Unit :	0.000001 times, which is 1 / (10 ⁶)			
Range :	-2147.000000 ~ +2147.000000			
Data Size :	32-bit			
Format :	DEC			
Example :	1100000 = 1.1 times			

Settings : (It will be provided after firmware version V1.017)

This parameter is used to magnify or minify the E-Cam table without changing its setting value.

For example, the data in the table is 0,10,20,30,40,20, magnification x 2.000000 equals to the data in the table: 0,20,40,60,80,40, magnification x 1.000000.

Enable the operation of E-Cam by using the same pulse frequency of the master axis. Magnifying the magnification will enlarge the route of E-Cam operation. The speed will be magnified as well.

Note: (1) This parameter can be set anytime, but will be effective only when pre-engaged → engaged.

(2) A2-L does not support E-Cam function.

P5-20	AC0	Acceleration/Deceleration Time (Number #0)		Address: 0528H 0529H
	Operational Interface :	Panel / Software	Communication	Related Section: 7.10
Default :	200			
Control Mode :	PR			
Unit :	ms			
Range :	1 ~ 65500			
Data Size :	16-bit			
Format :	Decimal			

Settings : The setting time of acceleration/deceleration in PR mode, which is the time it needs when accelerating from 0 to 3000 r/min.

P5-21	AC1	Acceleration/Deceleration Time (Number #1)		Address: 052AH 052BH
	Operational Interface :	Panel / Software	Communication	Related Section: 7.10
	Default :	300		
	Control Mode :	PR		
	Unit :	ms		
	Range :	1 ~ 65500		
	Data Size :	16-bit		
	Format :	Decimal		

Settings : Please refer to P5-20 for the setting of acceleration/deceleration time in PR mode.

P5-22	AC2	Acceleration/Deceleration Time (Number #2)		Address: 052CH 052DH
	Operational Interface :	Panel / Software	Communication	Related Section: 7.10
	Default :	500		
	Control Mode :	PR		
	Unit :	ms		
	Range :	1 ~ 65500		
	Data Size :	16-bit		
	Format :	Decimal		

Settings : Please refer to P5-20 for the setting of acceleration/deceleration time in PR mode.

P5-23	AC3	Acceleration/Deceleration Time (Number #3)		Address: 052EH 052FH
	Operational Interface :	Panel / Software	Communication	Related Section: 7.10
	Default :	600		
	Control Mode :	PR		
Unit :	ms			

Range :	1 ~ 65500
Data Size :	16-bit
Format :	Decimal

Settings : Please refer to P5-20 for the setting of acceleration/deceleration time in PR mode.

P5-24	AC4	Acceleration/Deceleration Time (Number #4)		Address: 0530H 0531H
	Operational Interface :	Panel / Software	Communication	Related Section: 7.10
	Default :	800		
	Control Mode :	PR		
	Unit :	ms		
	Range :	1 ~ 65500		
	Data Size :	16-bit		
	Format :	Decimal		

Settings : Please refer to P5-20 for the setting of acceleration/deceleration time in PR mode.

P5-25	AC5	Acceleration/Deceleration Time (Number #5)		Address: 0532H 0533H
	Operational Interface :	Panel / Software	Communication	Related Section: 7.10
	Default :	900		
	Control Mode :	PR		
	Unit :	ms		
	Range :	1 ~ 65500		
	Data Size :	16-bit		
	Format :	Decimal		

Settings : Please refer to P5-20 for the setting of acceleration/deceleration time in PR mode.

P5-26	AC6	Acceleration/Deceleration Time (Number #6)	Address: 0534H 0535H
	Operational Interface :	Panel / Software	Communication
	Default :	1000	
	Control Mode :	PR	
	Unit :	ms	
	Range :	1 ~ 65500	
	Data Size :	16-bit	
	Format :	Decimal	
	Settings :	Please refer to P5-20 for the setting of acceleration/deceleration time in PR mode.	

P5-27	AC7	Acceleration/Deceleration Time (Number #7)	Address: 0536H 0537H
	Operational Interface :	Panel / Software	Communication
	Default :	1200	
	Control Mode :	PR	
	Unit :	ms	
	Range :	1 ~ 65500	
	Data Size :	16-bit	
	Format :	Decimal	
	Settings :	Please refer to P5-20 for the setting of acceleration/deceleration time in PR mode.	

P5-28	AC8	Acceleration/Deceleration Time (Number #8)	Address: 0538H 0539H
	Operational Interface :	Panel / Software	Communication
	Default :	1500	
	Control Mode :	PR	
	Unit :	ms	

Range :	1 ~ 65500
Data Size :	16-bit
Format :	Decimal

Settings : Please refer to P5-20 for the setting of acceleration/deceleration time in PR mode.

P5-29	AC9	Acceleration/Deceleration Time (Number #9)		Address: 053AH 053BH
	Operational Interface :	Panel / Software	Communication	Related Section: 7.10
	Default :	2000		
	Control Mode :	PR		
	Unit :	ms		
	Range :	1 ~ 65500		
	Data Size :	16-bit		
	Format :	Decimal		

Settings : Please refer to P5-20 for the setting of acceleration/deceleration time in PR mode.

P5-30	AC10	Acceleration/Deceleration Time (Number #10)		Address: 053CH 053DH
	Operational Interface :	Panel / Software	Communication	Related Section: 7.10
	Default :	2500		
	Control Mode :	PR		
	Unit :	ms		
	Range :	1 ~ 65500		
	Data Size :	16-bit		
	Format :	Decimal		

Settings : Please refer to P5-20 for the setting of acceleration/deceleration time in PR mode.

P5-31	AC11	Acceleration/Deceleration Time (Number #11)	Address: 053EH 053FH
Operational Interface :	Panel / Software	Communication	Related Section: 7.10
Default :	3000		
Control Mode :	PR		
Unit :	ms		
Range :	1 ~ 65500		
Data Size :	16-bit		
Format :	Decimal		

Settings : Please refer to P5-20 for the setting of acceleration/deceleration time in PR mode.

P5-32	AC12	Acceleration/Deceleration Time (Number #12)	Address: 0540H 0541H
Operational Interface :	Panel / Software	Communication	Related Section: 7.10
Default :	5000		
Control Mode :	PR		
Unit :	ms		
Range :	1 ~ 65500		
Data Size :	16-bit		
Format :	Decimal		

Settings : Please refer to P5-20 for the setting of acceleration/deceleration time in PR mode.

P5-33	AC13	Acceleration/Deceleration Time (Number #13)	Address: 0542H 0543H
Operational Interface :	Panel / Software	Communication	Related Section: 7.10
Default :	8000		
Control Mode :	PR		
Unit :	ms		

Range :	1 ~ 65500
Data Size :	16-bit
Format :	Decimal

Settings : Please refer to P5-20 for the setting of acceleration/deceleration time in PR mode.

P5-34	AC14	Acceleration/Deceleration Time (Number #14)		Address: 0544H 0545H
	Operational Interface :	Panel / Software	Communication	Related Section: 7.10
	Default :	50		
	Control Mode :	PR		
	Unit :	ms		
	Range :	1 ~ 1500		
	Data Size :	16-bit		
	Format :	Decimal		

Settings : The default value of this parameter is smaller (short deceleration time) and it is used for deceleration time setting of auto protection.

P5-35	AC15	Acceleration/Deceleration Time (Number #15)		Address: 0546H 0547H
	Operational Interface :	Panel / Software	Communication	Related Section: 7.10
	Default :	30		
	Control Mode :	PR		
	Unit :	ms		
	Range :	1 ~ 1200		
	Data Size :	16-bit		
	Format :	Decimal		

Settings : The default value of this parameter is smaller (short deceleration time) and it is used for deceleration time setting of auto protection.

Note: The default value of this parameter is smaller and it is used for high-speed deceleration and stop.

P5-36	CAST	CAPTURE - Start Address of Data Array		Address: 0548H 0549H
Operational Interface :	Panel / Software	Communication	Related Section: 7.11.1	
Default :	0			
Control Mode :	ALL			
Unit :	-			
Range :	0 ~ (value set by P5-10 minus 1)			
Data Size :	16-bit			
Format :	Decimal			

Settings : The first data CAPTURE obtained should be saved in the address of data array.

Note: It is writable only when COMPARE stops (please refer to P5-39).

P5-37	CAAX	CAPTURE - Axis Position CNT		Address: 054AH 054BH
Operational Interface :	Panel / Software	Communication	Related Section: 7.11.1	
Default :	0			
Control Mode :	ALL			
Unit :	-			
Range :	-2147483648 ~ +2147483647			
Data Size :	32-bit			
Format :	Decimal			

Settings : Shows the axis position of CAPTURE pulse source

Note: 1) It is writable only when COMPARE stops (please refer to P5-39).

2) If the source is the main encoder, this parameter is write-protected and the content is the feedback position of the motor (monitoring variable 00h).

P5-38 ■	CANO	CAPTURE - The Number of Capturing Times		Address: 054CH 054DH
Operational Interface :	Panel / Software	Communication		Related Section: 7.11.1
Default :	1			
Control Mode :	ALL			
Unit :	-			
Range :	1 ~ (the value set by P5-10 minus the value set by P5-36)			
Data Size :	16-bit			
Format :	Decimal			

Settings : When CAPTURE stops, it means the number of data that expect to capture (readable and writable).

When CAPTURE activates, it means the number of data that has not been captured (read-only); every time, when it captures one data, the value of P5-38 will subtract one. When the value is 0, it means the capturing is completed.

- Note: 1. The number of data which is used by COMPARE, CAPTURE, and E-Cam cannot exceed 800.
2. A2-L does not support E-Cam function.

P5-39 ■	CACT	CAPTURE - Activate CAP Control		Address: 054EH 054FH
Operational Interface :	Panel / Software	Communication		Related Section: 7.11.1
Default :	0x2010			
Control Mode :	ALL			
Unit :	-			
Range :	0x0000 ~ 0xF13F			
Data Size :	16-bit			
Format :	Hexadecimal			

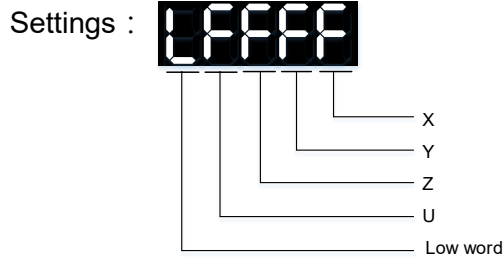

X: See the following table

bit	3	2	1	0
X function	Execute PR when finishing capturing	After capturing the first data, CMP is activated.	Reset the position of the first data	Activate CAP
Description	Execute PR # 50 after finishing CAP	It is invalid when CMP is activated.	After capturing the first data, reset the position coordinate	Starts to capture when it is set to 1. After finishing capturing, this bit becomes 0 automatically.

Y: 0 - CAPTURE is not working

1 - AUX ENC (linear scale) is set as the source

2 - PULSE Cmd

3 - Main ENC (main encoder)

When the source of CMP is CAP axis, the source Y of CAP cannot be changed.

Z: 0 - NO, 1 - NC

U: trigger the minimum interval (Unit: ms)

bit 0: When the value set by P5-38 is bigger than 0, set bit 0 to 1 will activate CAP function and DO.CAP_OK is OFF. Every time, when a data is captured, the value of P5-38 will subtract one. When the P5-38 is 0, it means the capture function is completed, DO.CAP_OK is ON and bit 0 will be reset to 0 automatically. If P5-38 equals to 0, set bit 0 to 1 will not activate CAP function. DO.CAP_OK is OFF and bit 0 will automatically be set to 0. If CAP function is activated, it cannot set 1 to bit 0. It only can be written 0 to disable CAP function.

bit 1: If this bit is 1, when capturing the first data, the current position of CAP axis will be set to the value of P5-76.

bit 2: If this bit is 1, when capturing the first data, CMP will be activated. (When bit 0 of P5-59 is set to 1 and P5-58 is set to the previous value.) If CMP has been activated, then this function is invalid.

bit 3: If this bit is 1, as soon as the CAP finished, PR procedure #50 will be triggered automatically.

P5-40	DLY0	Delay Time After Position Completed (Number #0)	Address: 0550H 0551H
	Operational Interface :	Panel / Software	Communication
	Default :	0	
	Control Mode :	PR	
	Unit :	ms	
	Range :	0 ~ 32767	
	Data Size :	16-bit	
	Format :	Decimal	

Related Section:
7.10

Settings : The 1st Delay Time of PR mode

P5-41	DLY1	Delay Time After Position Completed (Number #1)	Address: 0552H 0553H
	Operational Interface :	Panel / Software	Communication
	Default :	100	
	Control Mode :	PR	
	Unit :	ms	
	Range :	0 ~ 32767	
	Data Size :	16-bit	
	Format :	Decimal	

Related Section:
7.10

Settings : The 2nd Delay Time of PR mode

P5-42	DLY2	Delay Time After Position Completed (Number #2)	Address: 0554H 0555H
	Operational Interface :	Panel / Software	Communication
	Default :	200	
	Control Mode :	PR	
	Unit :	ms	
	Range :	0 ~ 32767	
	Data Size :	16-bit	
	Format :	Decimal	

Settings : The 3rd Delay Time of PR mode

P5-43	DLY3	Delay Time After Position Completed (Number #3)	Address: 0556H 0557H
	Operational Interface :	Panel / Software	Communication
	Default :	400	
	Control Mode :	PR	
	Unit :	ms	
	Range :	0 ~ 32767	
	Data Size :	16-bit	
	Format :	Decimal	

Settings : The 4th Delay Time of PR mode

P5-44	DLY4	Delay Time After Position Completed (Number #4)	Address: 0558H 0559H
	Operational Interface :	Panel / Software	Communication
	Default :	500	
	Control Mode :	PR	
	Unit :	ms	

Range :	0 ~ 32767
Data Size :	16-bit
Format :	Decimal

Settings : The 5th Delay Time of PR mode

P5-45	DLY5	Delay Time After Position Completed (Number #5)		Address: 055AH 055BH
	Operational Interface :	Panel / Software	Communication	Related Section: 7.10
	Default :	800		
	Control Mode :	PR		
	Unit :	ms		
	Range :	0 ~ 32767		
	Data Size :	16-bit		
	Format :	Decimal		

Settings : The 6th Delay Time of PR mode

P5-46	DLY6	Delay Time After Position Completed (Number #6)		Address: 055CH 055DH
	Operational Interface :	Panel / Software	Communication	Related Section: 7.10
	Default :	1000		
	Control Mode :	PR		
	Unit :	ms		
	Range :	0 ~ 32767		
	Data Size :	16-bit		
	Format :	Decimal		

Settings : The 7th Delay Time of PR mode

P5-47	DLY7	Delay Time After Position Completed (Number #7)		Address: 055EH 055FH
	Operational Interface :	Panel / Software	Communication	Related Section: 7.10
	Default :	1500		
	Control Mode :	PR		
	Unit :	ms		
	Range :	0 ~ 32767		
	Data Size :	16-bit		
	Format :	Decimal		

Settings : The 8th Delay Time of PR mode

P5-48	DLY8	Delay Time After Position Completed (Number #8)		Address: 0560H 0561H
	Operational Interface :	Panel / Software	Communication	Related Section: 7.10
	Default :	2000		
	Control Mode :	PR		
	Unit :	ms		
	Range :	0 ~ 32767		
	Data Size :	16-bit		
	Format :	Decimal		

Settings : The 9th Delay Time of PR mode

P5-49	DLY9	Delay Time After Position Completed (Number #9)		Address: 0562H 0563H
	Operational Interface :	Panel / Software	Communication	Related Section: 7.10
	Default :	2500		
	Control Mode :	PR		
Unit :	ms			

Range :	0 ~ 32767
Data Size :	16-bit
Format :	Decimal

Settings : The 10th Delay Time of PR mode

P5-50	DLY10	Delay Time After Position Completed (Number #10)		Address: 0564H 0565H
	Operational Interface :	Panel / Software	Communication	Related Section: 7.10
	Default :	3000		
	Control Mode :	PR		
	Unit :	ms		
	Range :	0 ~ 32767		
	Data Size :	16-bit		
	Format :	Decimal		

Settings : The 11th Delay Time of PR mode

P5-51	DLY11	Delay Time After Position Completed (Number #11)		Address: 0566H 0567H
	Operational Interface :	Panel / Software	Communication	Related Section: 7.10
	Default :	3500		
	Control Mode :	PR		
	Unit :	ms		
	Range :	0 ~ 32767		
	Data Size :	16-bit		
	Format :	Decimal		

Settings : The 12th Delay Time of PR mode

P5-52	DLY12	Delay Time After Position Completed (Number #12)	Address: 0568H 0569H
	Operational Interface :	Panel / Software	Communication
	Default :	4000	
	Control Mode :	PR	
	Unit :	ms	
	Range :	0 ~ 32767	
	Data Size :	16-bit	
	Format :	Decimal	

Settings : The 13th Delay Time of PR mode

P5-53	DLY13	Delay Time After Position Completed (Number #13)	Address: 056AH 056BH
	Operational Interface :	Panel / Software	Communication
	Default :	4500	
	Control Mode :	PR	
	Unit :	ms	
	Range :	0 ~ 32767	
	Data Size :	16-bit	
	Format :	Decimal	

Settings : The 14th Delay Time of PR mode

P5-54	DLY14	Delay Time After Position Completed (Number #14)	Address: 056CH 056DH
	Operational Interface :	Panel / Software	Communication
	Default :	5000	
	Control Mode :	PR	
	Unit :	ms	

Range :	0 ~ 32767
Data Size :	16-bit
Format :	Decimal

Settings : The 15th Delay Time of PR mode

P5-55	DLY15	Delay Time After Position Completed (Number #15)		Address: 056EH 056FH
	Operational Interface :	Panel / Software	Communication	Related Section: 7.10
	Default :	5500		
	Control Mode :	PR		
	Unit :	ms		
	Range :	0 ~ 32767		
	Data Size :	16-bit		
	Format :	Decimal		

Settings : The 16th Delay Time of PR mode

P5-56	CMST	COMPARE - Start Address of Data Array		Address: 0570H 0571H
	Operational Interface :	Panel / Software	Communication	Related Section: 7.11.2
	Default :	0		
	Control Mode :	ALL		
	Unit :	-		
	Range :	0 ~ (The value of P5-10 minus 1)		
	Data Size :	16-bit		
	Format :	Decimal		

Settings : The first COMPARE data is saved in the address of data array.

Note: It is writable only when COMPARE stops (please refer to P5-59).

P5-57 ■	CMAX	COMPARE - Axis Position		Address: 0572H 0573H
	Operational Interface :	Panel / Software	Communication	Related Section: 7.11.2
	Default :	0		
	Control Mode :	ALL		
	Unit :	-		
	Range :	-2147483648 ~ +2147483647		
	Data Size :	32-bit		
	Format :	Decimal		

Settings : The axis position of COMPARE pulse source is displayed here.
It is writable only when COMPARE stops (please refer to P5-59).

- Note: 1) It is write-protected when the source is Capture axis.
- 2) When the source is the main encoder, P5-57 is also write-protected. The pulse revolution is determined by parameter P1-46. When P5-59.Y is set to the main encoder, this parameter is set to the motor feedback position (monitoring variable 00h). If this parameter is not the same as the motor feedback position due to homing or reset by CAP function, the user can set P5-59.Y = 0 and then P5-59.Y = 3. In this way, this parameter will be reset to the motor feedback position.

P5-58 ■	CMNO	COMPARE - Compare Amount		Address: 0574H 0575H
	Operational Interface :	Panel / Software	Communication	Related Section: 7.11.2
	Default :	1		
	Control Mode :	ALL		
	Unit :	-		
	Range :	1 ~ (the value set by P5-10 minus the value set by P5-56)		
	Data Size :	16-bit		
	Format :	Decimal		

Settings : When COMPARE stops, it means the number of data that expect to compare (readable and writable).

When COMPARE activates, it means the number of data that has not been compared (read-only); every time, when it compares one data, the value of P5-38 will subtract one. When the value is 0, it means the comparing is completed.

P5-59	CMCT	COMPARE - Activate CMP Control		Address: 0576H 0577H
	Operational Interface :	Panel / Software	Communication	Related Section: 7.11.2
	Default :	0x00640010		
	Control Mode :	ALL		
	Unit :	-		
	Range :	0x00010000 ~ 0x0FFF313F		
	Data Size :	32-bit		
	Format :	Hexadecimal		

Settings :

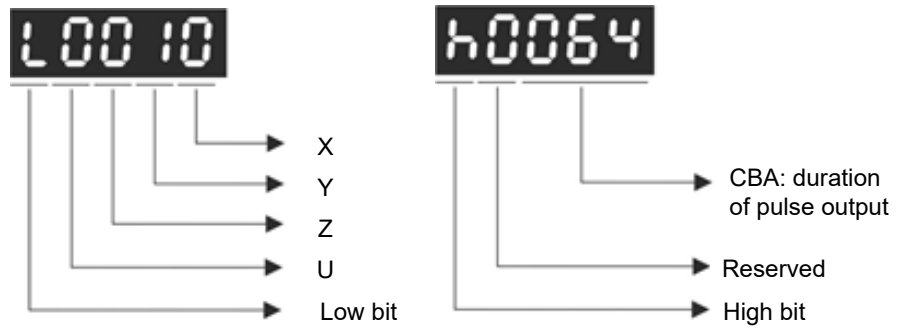

X: See the following table.

bit	3	2	1	0
X function	After finishing comparing, the counter returns to 0.	When finishing comparing, CAP is activated.	Cycle mode	CMP is activated
Description	As soon as the last data is compared, P5-57 is set to 0.	It is invalid when CAP is activated.	Never end	Starts to compare when this bit is set to 1. It returns to 0 when finishing comparing.

Y: 0 - When selecting CAPTURE AXES, the source of CAP cannot be changed.

1 - AUX ENC (linear scale) is set as the source

2 - PULSE Cmd

3 - Main ENC (main encoder)

Z: 0 - NO, 1 - NC outputs the polarity

U: See the table below:

bit	15	14	13	12
U function	-	-	-	Trigger PR
Description	-	-	-	When this bit is set to 1, PR#45 will be triggered after the last compare is completed. It is provided in V1.038 sub09 (or the later version)

CBA: Output the pulse length; Unit: 1 ms

bit 0: When the value of P5-58 is more than 0, setting bit 0 to 1 will activate CMP. When comparing one data, the value of P5-58 will subtract 1. When P5-58 is set to 0, the comparing is completed and returns to 0. If P5-58 is 0, setting bit 0 to 1 will not do any comparing and return to 0 automatically. If bit 0 has already been set to 1, it is not allowed to write 1 as the new value into the parameter. But it is ok to write 0 to disable CMP.

bit 1: If this bit is 1, P5-58 will be reset after comparing the last data. Then, start from the first data again. The cycle will never end and bit 0 is always 1.

bit 2: If this bit is 1, CAP will be activated after comparing the last data (Set bit 0 of P5-39 to 1 and reset P5-38 to the previous value). If CAP has already been activated, this function is invalid.

bit 3: If this bit is 1, set the counter (P5-57) to 0 after comparing the last data. For example, if the comparing data is set to 3000 (one data in total), the default value of the counter (P5-57) is 0. It is expected to input 4000 pulse. When it reaches the 3000th pulse, the CMP is completed and P5-57 returns to 0. When the pulse reaches 4000, P5-57=1000. (No accumulative error)

P5-60	POV0	Target Speed Setting #0		Address: 0578H 0579H
	Operational Interface :	Panel / Software	Communication	
Default :	20.0	200		
Control Mode :	PR			
Unit :	1 r/min	0.1 r/min		
Range :	0.1 ~ 6000.0	1 ~ 60000		
Data Size :	16-bit			
Format :	Decimal			
Example :	15 = 15 r/min	150 = 15 r/min		

Settings : The 1st target speed of PR mode

P5-61	POV1	Target Speed Setting #1		Address: 057AH 057BH
	Operational Interface :	Panel / Software	Communication	Related Section: 7.10
	Default :	50.0	500	
	Control Mode :	PR		
	Unit :	1 r/min	0.1 r/min	
	Range :	0.1 ~ 6000.0	1 ~ 60000	
	Data Size :	16-bit		
	Format :	Decimal		
	Example :	1 = 1 r/min	10 = 1 r/min	

Settings : The 2nd target speed of PR mode

P5-62	POV2	Target Speed Setting #2		Address: 057CH 057DH
	Operational Interface :	Panel / Software	Communication	Related Section: 7.10
	Default :	100.0	1000	
	Control Mode :	PR		
	Unit :	1 r/min	0.1 r/min	
	Range :	0.1 ~ 6000.0	1 ~ 60000	
	Data Size :	16-bit		
	Format :	Decimal		
	Example :	1 = 1 r/min	10 = 1 r/min	

Settings : The 3rd target speed of PR mode

P5-63	POV3	Target Speed Setting #3		Address: 057EH 057FH
	Operational Interface :	Panel / Software	Communication	Related Section: 7.10
	Default :	200.0	2000	
	Control Mode :	PR		
	Unit :	1 r/min	0.1 r/min	
	Range :	0.1 ~ 6000.0	1 ~ 60000	
	Data Size :	16-bit		
	Format :	Decimal		
	Example :	1 = 1 r/min	10 = 1 r/min	

Settings : The 4th target speed of PR mode

P5-64	POV4	Target Speed Setting #4		Address: 0580H 0581H
	Operational Interface :	Panel / Software	Communication	Related Section: 7.10
	Default :	300.0	3000	
	Control Mode :	PR		
	Unit :	1 r/min	0.1 r/min	
	Range :	0.1 ~ 6000.0	1 ~ 60000	
	Data Size :	16-bit		
	Format :	Decimal		
	Example :	1 = 1 r/min	10 = 1 r/min	

Settings : The 5th target speed of PR mode

P5-65	POV5	Target Speed Setting #5		Address: 0582H 0583H
	Operational Interface :	Panel / Software	Communication	Related Section: 7.10
	Default :	500.0	5000	
	Control Mode :	PR		
	Unit :	1 r/min	0.1 r/min	
	Range :	0.1 ~ 6000.0	1 ~ 60000	
	Data Size :	16-bit		
	Format :	Decimal		
	Example :	1 = 1 r/min	10 = 1 r/min	

Settings : The 6th target speed of PR mode

P5-66	POV6	Target Speed Setting #6		Address: 0584H 0585H
	Operational Interface :	Panel / Software	Communication	Related Section: 7.10
	Default :	600.0	6000	
	Control Mode :	PR		
	Unit :	1 r/min	0.1 r/min	
	Range :	0.1 ~ 6000.0	1 ~ 60000	
	Data Size :	16-bit		
	Format :	Decimal		
	Example :	1 = 1 r/min	10 = 1 r/min	

Settings : The 7th target speed of PR mode

P5-67	POV7	Target Speed Setting #7		Address: 0586H 0587H
	Operational Interface :	Panel / Software	Communication	Related Section: 7.10
	Default :	800.0	8000	
	Control Mode :	PR		
	Unit :	1 r/min	0.1 r/min	
	Range :	0.1 ~ 6000.0	1 ~ 60000	
	Data Size :	16-bit		
	Format :	Decimal		
	Example :	1 = 1 r/min	10 = 1 r/min	

Settings : The 8th target speed of PR mode

P5-68	POV8	Target Speed Setting #8		Address: 0588H 0589H
	Operational Interface :	Panel / Software	Communication	Related Section: 7.10
	Default :	1000.0	10000	
	Control Mode :	PR		
	Unit :	1 r/min	0.1 r/min	
	Range :	0.1 ~ 6000.0	1 ~ 60000	
	Data Size :	16-bit		
	Format :	Decimal		
	Example :	1 = 1 r/min	10 = 1 r/min	

Settings : The 9th target speed of PR mode

P5-69	POV9	Target Speed Setting #9		Address: 058AH 058BH
	Operational Interface :	Panel / Software	Communication	Related Section: 7.10
	Default :	1300.0	13000	
	Control Mode :	PR		
	Unit :	1 r/min	0.1 r/min	
	Range :	0.1 ~ 6000.0	1 ~ 60000	
	Data Size :	16-bit		
	Format :	Decimal		
	Example :	1 = 1 r/min	10 = 1 r/min	

Settings : The 10th target speed of PR mode

P5-70	POV10	Target Speed Setting #10		Address: 058CH 058DH
	Operational Interface :	Panel / Software	Communication	Related Section: 7.10
	Default :	1500.0	15000	
	Control Mode :	PR		
	Unit :	1 r/min	0.1 r/min	
	Range :	0.1 ~ 6000.0	1 ~ 60000	
	Data Size :	16-bit		
	Format :	Decimal		
	Example :	1 = 1 r/min	10 = 1 r/min	

Settings : The 11th target speed of PR mode

P5-71	POV11	Target Speed Setting #11		Address: 058EH 058FH
	Operational Interface :	Panel / Software	Communication	Related Section: 7.10
	Default :	1800.0	18000	
	Control Mode :	PR		
	Unit :	1 r/min	0.1 r/min	
	Range :	0.1 ~ 6000.0	1 ~ 60000	
	Data Size :	16-bit		
	Format :	Decimal		
	Example :	1 = 1 r/min	10 = 1 r/min	

Settings : The 12th target speed of PR mode

P5-72	POV12	Target Speed Setting #12		Address: 0590H 0591H
	Operational Interface :	Panel / Software	Communication	Related Section: 7.10
	Default :	2000.0	20000	
	Control Mode :	PR		
	Unit :	1 r/min	0.1 r/min	
	Range :	0.1 ~ 6000.0	11 ~ 60000	
	Data Size :	16-bit		
	Format :	Decimal		
	Example :	1 = 1 r/min	10 = 1 r/min	

Settings : The 13th target speed of PR mode

P5-73	POV13	Target Speed Setting #13		Address: 0592H 0593H
	Operational Interface :	Panel / Software	Communication	Related Section: 7.10
	Default :	2300.0	23000	
	Control Mode :	PR		
	Unit :	1 r/min	0.1 r/min	
	Range :	0.1 ~ 6000.0	1 ~ 60000	
	Data Size :	16-bit		
	Format :	Decimal		
	Example :	1 = 1 r/min	10 = 1 r/min	

Settings : The 14th target speed of PR mode

P5-74	POV14	Target Speed Setting #14		Address: 0594H 0595H
	Operational Interface :	Panel / Software	Communication	Related Section: 7.10
	Default :	2500.0	25000	
	Control Mode :	PR		
	Unit :	1 r/min	0.1 r/min	
	Range :	0.1 ~ 6000.0	1 ~ 60000	
	Data Size :	16-bit		
	Format :	Decimal		
	Example :	1 = 1 r/min	10 = 1 r/min	

Settings : The 15th target speed of PR mode

P5-75	POV15	Target Speed Setting #15		Address: 0596H 0597H
	Operational Interface :	Panel / Software	Communication	Related Section: 7.10
	Default :	3000.0	30000	
	Control Mode :	PR		
	Unit :	1 r/min	0.1 r/min	
	Range :	0.1 ~ 6000.0	1 ~ 60000	
	Data Size :	16-bit		
	Format :	Decimal		
	Example :	1 = 1 r/min	10 = 1 r/min	

Settings : The 16th target speed of PR mode

P5-76★	CPRS	CAPTURE - First Position Reset Data		Address: 0598H 0599H
	Operational Interface :	Panel / Software	Communication	Related Section: 7.10
	Default :	0		
	Control Mode :	ALL		
	Unit :	-		
	Range :	-1073741824 ~ +1073741823		
	Data Size :	32-bit		
	Format :	Decimal		

Settings : Please refer to the description of P5-39 X1.

P5-77	CSAX	The Position of Synchronous Capture Axis (CAP SYNC AXES)	Address: 059AH 059BH
	Operational Interface :	Panel / Software	Communication
	Default :	0	
	Control Mode :	ALL	
	Unit :	-	
	Range :	-2147483648 ~ +2147483647	
	Data Size :	32-bit	
	Format :	Decimal	

Related Section: -

Settings : The position of this axis will synchronize with CAP signal. That is to say, when activating CAP every two times, the motor moving distance of this axis is the value of P5-78. (There is no accumulative error and only in single-way operation) The synchronous capture axis can be the source of Master.

Note: A2-L does not support E-Cam function.

P5-78	CSDS	The Interval Pulse Number between Each Synchronous Capture Axis	Address: 059CH 059DH
	Operational Interface :	Panel / Software	Communication
	Default :	100	
	Control Mode :	ALL	
	Unit :	Pulse	
	Range :	10 ~ +100000000	
	Data Size :	32-bit	
	Format :	Decimal	

Related Section: -

Settings : It is the moving distance of synchronous capture axis between two CAP actions.

The new value can be written into the parameter not until CAP is disabled (P5-39, X0=0).

Note: A2-L does not support E-Cam function.

P5-79	CSDS	Error Pulse Number of Synchronous Capture Axis		Address: 059EH 059FH
	Operational Interface :	Panel / Software	Communication	Related Section: -
	Default :	0		
	Control Mode :	ALL		
	Unit :	Pulse unit of capture axis		
	Range :	-2147483648 ~ +2147483647		
	Data Size :	32-bit		
	Format :	Decimal		

Settings : When synchronous capture axis is operating, the synchronous error should be 0. This parameter shows this error value. The followings are its concept:

$$\begin{aligned} \text{Synchronous Error} &= \text{Output value of synchronous axis} - \text{Setting value of synchronous axis} \\ &= \text{the accumulative amount of P5-77} - (\text{P5-78} \times \text{Capturing number of times}) \end{aligned}$$

When capturing the data, the synchronous axis works normally. This parameter updates once.

This parameter can be written into as well. It indicates the offset of synchronous master. When the synchronous capture axis is regarded as the master of flying shear, modify this parameter can deviate the cutting position to the left/right.

Note: A2-L does not support E-Cam function.

P5-80	CSDS	Max. Correction Rate of Synchronous Capture Axis		Address: 05A0H 05A1H
	Operational Interface :	Panel / Software	Communication	Related Section: -
	Default :	10		
	Control Mode :	ALL		
	Unit :	%		
	Range :	0 ~ 90		
	Data Size :	16-bit		
	Format :	Decimal		

Settings : This parameter limits the percentage (%) of synchronous adjustment.
Correction rate

$$= \frac{\text{pulse number output by synchronous axis}}{\text{pulse number input by synchronous axis} (100 - P5 - 80)\%} < \text{correctionrate} < (100 + P5 - 80)\%$$

The bigger correction rate, the faster the synchronous error becomes 0. However, the speed changing will be more severe.

The smaller correction rate, the slower the synchronous error becomes 0. However, the speed changing will be smoother.

In the application of flying shear, after adjusting the synchronous error, P5-79: the bigger parameter value will reduce the time the slave axis goes to the desired position. However, the speed is not synchronized.

Note: A2-L does not support E-Cam function.

P5-81	ECHD	E-CAM: Start Address of Data Array		Address: 05A2H 05A3H
	Operational Interface :	Panel / Software	Communication	Related Section: 7.11
	Default :	100		
	Control Mode :	PR		
	Unit :	-		
	Range :	0 ~ (800 - P5-82)		
	Data Size :	16-bit		
	Format :	Decimal		

Settings : The first data of E-Cam table is saved in the address of data array.

- Note:
1. Version V1.015 (before): This parameter cannot be modified when E-Cam is activated (P5-88, X = 1).
 2. Version V1.015 (included or after): This parameter can be set anytime, but will be effective only when pre-engaged → engaged.
 3. A2-L does not support this function.

P5-82	ECMN	E-CAM: Area Number N (at least >=5)		Address: 05A4H 05A5H
	Operational Interface :	Panel / Software	Communication	Related Section: 7.11
	Default :	5		
Control Mode :	PR			

Unit :	-
Range :	5 ~ 720, must <= (P5-10 - P5-81) And P5-82 x P5-84 <= 2147483647
Data Size :	16-bit
Format :	Decimal

Settings : It means the E-Cam curve is divided into N area, and the table should include N+1 data.

- Note: 1. This parameter can be wrote when E-Cam stops (Please refer to P5-88, X=0).
2. A2-L does not support E-Cam function.

P5-83	ECMM	E-CAM: Master Gear Ratio Setting M	Address: 05A6H 05A7H
--------------	-------------	---	---------------------------------

Operational Interface :	Panel / Software	Communication	Related Section: 7.11
Default :	1		
Control Mode :	PR		
Unit :	-		
Range :	1 ~ 32767		
Data Size :	16-bit		
Format :	Decimal		

Settings : When receiving pulse number P of the Master, E-Cam will rotate M circle, which means the M cycle of the E-Cam table.

- Note: 1. This parameter can be wrote when E-Cam stops (Please refer to P5-88, X=0).
2. A2-L does not support E-Cam function.

P5-84	ECMP	E-CAM: Master Gear Ratio Setting P	Address: 05A8H 05A9H
--------------	-------------	---	---------------------------------

Operational Interface :	Panel / Software	Communication	Related Section: 7.11
Default :	3600		
Control Mode :	PR		
Unit :	-		

Range :	10 ~ 1073741823, and P5-82 x P5-83 < = P5-84 and P5-82 x P5-84 < = 2147483647
Data Size :	32-bit
Format :	Decimal

Settings : When receiving pulse number P of the Master, E-Cam will rotate M circle, which means the M cycle of the E-Cam table.

- Note:
1. This parameter can be written when E-Cam stops (Please refer to P5-88, X=0).
 2. Version V1.018 (included or after): This parameter can be modified anytime, and has no limit that mentioned above.
 3. A2-L does not support E-Cam function.

P5-85	ECME	E-CAM: Number of Area		Address: 05AAH 05ABH
	Operational Interface :	Panel / Software	Communication	Related Section: 7.11
	Default :	0		
	Control Mode :	PR		
	Unit :	-		
	Range :	0 ~ (P5-82 - 1)		
	Data Size :	16-bit		
	Format :	Decimal		

Settings : The area number of E-cam when E-cam engaged.

Note: A2-L does not support E-Cam function.

P5-86	ECAX	E-CAM: Master Axis Position		Address: 05ACH 05ADH
	Operational Interface :	Panel / Software	Communication	Related Section: 7.11
	Default :	0		
	Control Mode :	PR		
	Unit :	-		
	Range :	-2147483648 ~ +2147483647		

Data Size :	32-bit
Format :	Decimal

Settings : The position counter of the E-Cam Master

- Note: 1. This parameter can be written when E-Cam stops (Please refer to P5-88, X=0).
2. A2-L does not support E-Cam function.

P5-87	PLED	E-CAM: Lead Pulse		Address: 05AEH 05AFH
	Operational Interface :	Panel / Software	Communication	Related Section: 7.11
	Default :	0		
	Control Mode :	PR		
	Unit :	-		
	Range :	-1073741824 ~ +1073741823		
	Data Size :	32-bit		
	Format :	Decimal		

Settings : When the engaging condition (P5-88.Z) of E-cam is satisfied, the pulse number from the master has to exceed the setting value of this parameter, so that E-cam is fully engaged.

In other words, E-cam engages after neglecting the lead pulse specified by this parameter.

If the symbol of this parameter is +, it means the received forward pulse is regarded as the lead pulse.

If the symbol of this parameter is - , it means the received reverse pulse is regarded as the lead pulse.

Note: A2-L does not support E-Cam function.

P5-88	ECON	E-CAM: Activate E-Cam Control		Address: 05B0H 05B1H
	Operational Interface :	Panel / Software	Communication	Related Section: 7.11
	Default :	0x00000000		
	Control Mode :	PR		

Unit :	-
Range :	0x00000000 ~ 0x203FF257
Data Size :	32-bit
Format :	Hexadecimal

Settings : The format of this parameter: (High word h) S0BA : (Low word L) UZYX

Definition of each column is as follows:

- X: E-Cam command

Description of each bit:

X3	-	-
X2	P5-19 is effective immediately	It is available after V1.038 sub48: 0: P5-19 is effective after the next engage. 1: P5-19 is effective immediately.
X1	E-Cam does not disengage when Servo OFF	It is available after V1.038 sub29: 0: E-Cam does not work 1: When E-Cam stops because of alarm or Servo Off, it can keep in engaged status. When re-servo on, E-cam can operate directly. It can return to the correct position by macro #D.
X0	E-Cam is enabled	0: E-Cam is disabled 1: E-Cam is enabled (E-CAM is enabled while other functions cannot be modified.)

- Y: Command source
 - 0: CAP axis
 - 1: AUX ENC
 - 2: Pulse Cmd
 - 3: PR command
 - 4: Time Axis (1 ms)
 - 5: Synchronous Capture Axis (P5-77)
 - 6: Analog channel 1 (virtual axis, Unit: 1M pulse/s /10V)
- Z: Engaging Time (No multiple choice)
 - 0: Immediately
 - 1: DI.CAM ON
 - 2: Any one of the Capture

- U: Disengaging Condition (2, 4 and 6 cannot be selected at the same time)

U	Disengaged Condition	Action after disengaged
0	Never disengaged	-
1	Disengage after DI.CAM is OFF	In STOP status
2	Master axis receives the pulse number which is set by P5-89 and stops immediately. (The symbol represents the direction)	In STOP status
6	(It is available after firmware version V1.009) Same as 2, the E-cam starts to decelerate when disengaging. It is suitable for the application of calling the next PR position command right after disengaged.	
4	(It is available after firmware version V1.009) Master axis exceeds the setting value of P5-89 (Sign indicates the direction)	Back to the pre-engage status The lead pulse is P5-92
8	When U = 1, 2 or 6: Disable E-Cam after it is disengaged.	Set X to 0
	When U = 4: To avoid jittering when it returns to lead status.	N/A

Note: (1) The servo is Off, when ALM or forward/reverse limit occur or PR is doing homing procedure, it disengages (P5-88, X = 0)

- BA: When disengaging condition is satisfied (P5-88, U = 2, 4, 6), a PR 00 ~ 63 (hexadecimal; 00 means no action) will automatically be executed.
- S: Shows the engage status (Read-only, the setting is invalid)
 - 0: Stop
 - 1: Engage status
 - 2: Pre-engage status

(2) A2-L does not support E-cam function.

P5-89	ECRD	E-CAM: Information of Disengaging Time		Address: 05B2H 05B3H
	Operational Interface :	Panel / Software	Communication	Related Section: 7.11
	Default :	0		
	Control Mode :	PR		
	Unit :	-		
	Range :	-1073741824 ~ +1073741823		
	Data Size :	32-bit		
	Format :	Decimal		

Settings : (Please refer to the definition of P5-88 U setting value 2)

Note: A2-L does not support E-Cam function.

P5-90	CMAP	E-CAM: AREA No. + The Point of DO ON		Address: 05B4H 05B5H
	Operational Interface :	Panel / Software	Communication	Related Section: 7.11
	Default :	270		
	Control Mode :	PR		
	Unit :	Degree (It was changed after firmware V1.009)		
	Range :	0 ~ 360		
	Data Size :	16-bit		
	Format :	Decimal		

Settings : When E-cam is engaged, set the start angle of DO output (DO. CAM_AREA).

Note: A2-L does not support E-Cam function.

P5-91	CMAN	E-CAM: AREA No. - The Point of DO OFF		Address: 05B6H 05B7H
Operational Interface :	Panel / Software	Communication		Related Section: 7.11
Default :	360			
Control Mode :	PR			
Unit :	Degree (It was changed after firmware V1.009)			
Range :	0 ~ 360			
Data Size :	16-bit			
Format :	Decimal			

Settings : When E-cam is engaged, set the end angle of DO output (DO. CAM_AREA).

Note: A2-L does not support E-cam function.

P5-92	PLED	E-CAM: Pre-engaged Time of Each Cycle		Address: 05B8H 05B9H
Operational Interface :	Panel / Software	Communication		Related Section: 7.11
Default :	0			
Control Mode :	PR			
Unit :	-			
Range :	-2147483648 ~ +2147483647			
Data Size :	32-bit			
Format :	Decimal			

Settings : Version V1.006 sub04 (included or after):

This parameter goes with the selection of P5-88, U=4 (E-cam will disengage if it exceeds the moving distance):

After disengaging, it does not enter the Stop status but pre-engaged status. The lead pulse is determined by this parameter.

The pulse number sent by the Master must exceed the setting value of this parameter so that E-cam will engage again.

In other words, E-cam will engage not until the lead pulse is ignored.

If the symbol of this parameter is + , it means the received positive pulse will be regarded as the lead pulse.

If the symbol of this parameter is - , it means the received negative pulse will be regarded as the lead pulse.

Note: A2-L does not support E-cam function.

P5-93	CSDS	Motion Control Macro Command: Command Parameter # 4		Address: 05BAH 05BBH
	Operational Interface :	Panel / Software	Communication	Related Section: -
	Default :	0		
	Control Mode :	ALL		
	Unit :	-		
	Range :	-100000000 ~ +100000000		
	Data Size :	32-bit		
	Format :	Decimal		

Settings : Before issuing the macro command, the relevant parameters # 4 must be set in advance.

The function of the parameter is determined by the macro command. Not every macro command has its relevant parameters.

P5-94	CSDS	Motion Control Macro Command: Command Parameter # 3		Address: 05BCH 05BDH
	Operational Interface :	Panel / Software	Communication	Related Section: -
	Default :	0		
	Control Mode :	ALL		
	Unit :	-		
	Range :	-2147483648 ~ +2147483647		
	Data Size :	32-bit		
	Format :	Decimal		

Settings : Before issuing the macro command, the relevant parameters # 3 must be set in advance.

The function of the parameter is determined by the macro command.
Not every macro command has its relevant parameters.

P5-95	CSDS		Motion Control Macro Command: Command Parameter # 2	Address: 05BEH 05BFH
	Operational Interface :	Panel / Software	Communication	Related Section: -
Default :	0			
Control Mode :	ALL			
Unit :	-			
Range :	-2147483648 ~ +2147483647			
Data Size :	32-bit			
Format :	Decimal			

Settings : Before issuing the macro command, the relevant parameters # 2 must be set in advance.

The function of the parameter is determined by the macro command.
Not every macro command has its relevant parameters.

P5-96	CSDS		Motion Control Macro Command: Command Parameter # 1	Address: 05C0H 05C1H
	Operational Interface :	Panel / Software	Communication	Related Section: -
Default :	0			
Control Mode :	ALL			
Unit :	-			
Range :	-2147483648 ~ +2147483647			
Data Size :	32-bit			
Format :	Decimal			

Settings : Before issuing the macro command, the relevant parameters # 1 must be set in advance.

The function of the parameter is determined by the macro command.
Not every macro command has its relevant parameters.

P5-97	CSDS	Motion Control Macro Command: Issue Command / Executing Result		Address: 05C2H 05C3H
	Operational Interface :	Panel / Software	Communication	Related Section: -
	Default :	0x0000		
	Control Mode :	ALL		
	Unit :	-		
	Range :	0x0000~0x099F		
	Data Size :	16-bit		
	Format :	Hexadecimal		

Settings : Write-in: It is used to issue the macro command (0x0CBA)
 Read: It is used to examine the execution result of macro command (If success, the result will be sent back to 0x1CBA).
 If the command issues 0001, 0x1001 will be sent back when success; and 0xFxxx when failed (depending on the command description).
 If issuing the command that is not supported, the failure code 0xF001 will be sent back.

The provided command code is as the followings.

The following macros are available from Version V1.027 (included):

Command code 0x0003	Motion parameter protection: password setting, protection activation
Macro parameters	<p>P5-93 = parameter write-protected level (0 ~ 1) (0: no protection, 1: enable protection)</p> <p>P5-94 = protection level of data array (-1 to 7)</p> <p>0: password protection of all data array</p> <p>1: password protection of data array #100 ~ #799</p> <p>2: password protection of data array #200 ~ #799</p> <p>3: password protection of data array #300 ~ #799</p> <p>4: password protection of data array #400 ~ #799</p> <p>5: password protection of data array #500 ~ #799</p> <p>6: password protection of data array #600 ~ #799</p> <p>7: no password protection of data array</p> <p>P5-95 = set new password (1 ~ 16777215)</p> <p>P5-96 = confirm new password (1 ~ 16777215)</p> <p>Note: P5-95 must be equal to P5-96 to be successfully set and the password must be set within the allowable range.</p>
<p>This function can be executed before activating the function of parameter protection.</p> <p>If the protection function is activated, when repeat execute this function, the failure code will be sent back.</p>	
Failure code	Protection function has been activated and cannot be set

0xF031	repeat.
Failure code 0xF032	Wrong password setting: P5-95 is not equal to P5-96.
Failure code 0xF033	Password setting exceeds the allowable range (1 ~ 16777215).
Failure code 0xF034	The protection level, P5-94 exceeds the allowable range (-1 ~ 7).
Failure code 0xF035	The protection level, P5-93 exceeds the allowable range (0 ~ 1).
Success code 0x1003	

The following macros are available from version V1.026 (included):

Command code 0x0004	Motion parameter protection: unlock the protection
Macro parameters	P5-96= enter the password (1 ~ 16777215)
<p>This function can be executed when activating the function of parameter protection. If the protection function is unlocked, repeat execute this function will sent back the failure code.</p> <p>If entering the wrong password, failure code Ennn will be sent back. nnn means the rest decode number. It will be misused one number after one failure. When the number is 0, it will be locked for good.</p>	
Failure code 0xF041	Protection function is unlocked and it cannot repeat unlock.
Failure code 0xF043	The password setting exceed the allowable range (1 ~ 16777215)
Failure code 0xF044	<p>The number of times of entering wrong password exceeds the limit: Lock for good.</p> <p>Reset the parameter (P2-08=10) to unlock it is the only method. However, all parameter will return to the default value.</p>
Failure code 0xEnnn	<p>Incorrect password setting: Failed to unlock.</p> <p>nnn: the rest decode number. It will be minuses one number after one failure. When the number is 0, it will be locked for good.</p>
Success code 0x1004	

The following macros are available from version 1.024 (included):

Command code 0x0006	Build up E-Cam table: flying shear, including synchronous area (7 areas)
General parameters	<p>P5-81= Address of table (Data array)</p> <p>P5-82 = 7 (This macro is fixed to 7 areas)</p> <p>P1-44, P1-45 = E-gear ratio (it has to be setup in advance)</p>
Macro parameters	P5-94 = A (Deceleration ratio: numerator) x C (Number of cutter)

	<p>P5-95= B (Deceleration ratio: denominator) P5-96= 1000000 x R x V Among them: R (cutting ratio) = L (cutting length) / ℓ (Girth of cutter) Allowable cutting ratio: (0.3 ~ 2.5) times V (Speed factor) = target cutting speed / speed of delivered product V=1.0: When cutting, the speed of cutter is the same as the product V=1.1: When cutting, the speed of cutter is 10% faster than the product V=0.9: When cutting, the speed of cutter is 10% slower than the product ..., and so forth.</p>
	<p>This macro will calculate the data of E-Cam table according to the above-mentioned parameters, and store in data array which designated by P5-81. Parameters listed above are related to E-Cam table calculation. Please correctly setup those parameters before executing this macro.</p> <p>After this macro is executed, if the above parameters have been changed, it has to recreate the E-Cam table and this macro will have to be executed again. Data in E-Cam table will be changed after executing this macro; thus, do not execute it when E-Cam is in engaged status.</p> <p>In E-Cam application, parameters, such as P5-83 and P5-84 that are not related to this macro are not listed here. Users could setup parameters according to the real application. Please refer to Chapter 7, sections about E-Cam.</p> <p>After executing this macro, E-Cam table will not be saved to EEPROM automatically.</p>
Failure code 0xF061	When creating the table, E-Cam is in engaged status.
Failure code 0xF062	The setting value of P5-94 exceeds the range: (1 ~ 65535)
Failure code 0xF063	The setting value of P5-95 exceeds the range: (1 ~ 65535)
Failure code 0xF064	The setting value of P5-96 exceeds the range: (300000 ~ 2500000)
Failure code 0xF065	The address specified by P5-81 is too long and the space of data array is not enough.
Failure code 0xF066	The setting value of P5-82 should be set to 7. Otherwise the command cannot be executed.
Failure code 0xF067	Data calculation error. Please decrease the setting value of (P1-44, P1-45) and keep the proportion will do.

Command code 0x0007	Create E-Cam table: Flying cut (multi-degree of freedom)
General parameters	P5-81 = Address of table (data array) P5-82 = N (30~72) (Area number of E-Cam) P1-44, P1-45 = E-gear ration (has to be setup first)
Macro parameters	<p>P5-93.H16 (high 16-bit) = S P5-93.L16 (low 16-bit) = W Among them: S (curve level) = 1 ~ 4 levels W (degree of waiting area) = -1 ~ 170 degrees W = -1 is available in firmware version V1.038 (sub29) (or the later version) P5-94 = Y (degree of synchronous area) = 0 ~ 330 degrees P5-95.H16 (high 16-bit) = A x C P5-95.L16 (low 16-bit) = B Among them: A (Deceleration ratio: numerator), C (Number of cutter) B (Deceleration ratio: denominator) P5-96 = 1000000 x R x V Among them: R (cutting ratio) = L (target cutting length) / l (Length of cutter) Allowable cutting ratio: (0.05 ~ 5.0) times V (speed factor) = target cutting speed / speed of delivered product V=1.0: When cutting, the speed of cutter is the same as the product V=1.1: When cutting, the speed of cutter is 10% faster than the product V=0.9: When cutting, the speed of cutter is 10% slower than the product ..., and so forth.</p>
<p>Note: $W' = 180 + 360/N - 360/R + Y/2$ When <ol style="list-style-type: none"> 1. P5-93.L16 < W', E-cam table is in error (failure code F07Ah) 2. P5-93.L16 = W', the initial speed is 0 in E-Cam table 3. P5-93.L16 > W', the initial speed > 0 in E-Cam table This macro will calculate the data of E-Cam table according to the above-mentioned parameters, and store in data array which designated by P5-81. Parameters listed above are related to E-Cam table calculation. Please correctly setup those parameters before executing this macro.</p>	
<p>After this macro is executed, if the above parameters have been changed, it has to recreate the E-Cam table and this macro will have to be executed again. Data in E-Cam table will be changed after executing this macro; thus, do not execute</p>	

<p>it when E-Cam is in engaged status. In E-Cam application, parameters, such as P5-83 and P5-84 that are not related to this macro are not listed here. Users could setup parameters according to the real application. Please refer to Chapter 7, sections about After executing this macro, E-Cam table will not be saved to EEPROM automatically.</p>	
Failure code 0xF071	When creating the table, E-Cam is in engaged status.
Failure code 0xF072	P5-94 degree of synchronous area exceeds the range: (0 ~ 330)
Failure code 0xF073	P5-93.H16 curve level exceeds the range: (1 ~ 4)
Failure code 0xF074	P5-93.L16 degree of waiting area exceeds the range: (1 ~ 170)
Failure code 0xF075	The setting value of P5-96 exceeds the range: (50000 ~ 5000000)
Failure code 0xF076	P5-82 area number of E-Cam exceeds the range: (30 ~ 72)
Failure code 0xF077	The address specified by P5-81 is too long and the space of data array is not enough.
Failure code 0xF078	Data calculation error. Please decrease the setting value of (P1-44, P1-45) and keep the proportion will do.
Failure code 0xF079	Acceleration degree is too small, and then please decreases the value of waiting area (W), synchronous area (Y) or curve level (S).
Failure code 0xF07A	Waiting area is too small, then please increase the value of acceleration area (W) or decrease the value of synchronous area (Y)

The following macros are available from version V1.042 sub09 (included):

Command code 0x0008	E-Cam curve scaling (P5-19) is effective immediately
Macro parameters	N/A
<p>This macro can be triggered when E-cam is engaged. P5-19 is effective immediately.</p> <p>Usually, E-Cam scaling is only changed by P5-19 when it entering the engaged condition (see transition 3). It cannot be changed in engaged condition. E-Cam scaling only can be changed after one E-Cam cycle so as to make sure the E-Cam can return to the original position without accumulative error.</p> <pre> graph TD Engaged[Engaged: 1] -- 5 --> Stop[Stop: 0] Engaged -- 4 --> Lead[Lead: 2] Stop -- 1 --> Engaged Stop -- 2 --> Lead Lead -- 3 --> Engaged </pre> <p style="color: blue;">P5-19 is loading into E-Cam scaling.</p>	

<p>In application, two ways can change the setting of E-Cam curve scaling.</p> <ol style="list-style-type: none"> P5-88.X2 = 1: When E-Cam is engaged, setup this bit at the same time. Function of P5-19 will be enabled immediately. Use macro#8: Every time when this macro command is triggered, function of P5-19 will be enabled. However, if the value of P5-19 is changed and this macro is not triggered, function of P5-19 will not be enabled. This macro command has to be triggered again. 	
Failure code	N/A

The following macros are available from version V1.035 sub00 (included):

Command code 0x000C	Change position X, where E-Cam is engaged: E-Cam disengages after rotating one cycle at forward direction.
General parameters	N/A
Macro parameters	<p>P5-93 = New engaged position X. Unit: pulse number of master axis.</p> <p>Monitoring variable 062(3Eh): It displays the current engaged position (X) of master axis.</p>

This macro command can change the engaged position even when E-Cam is engaged. It will automatically calculate the residual engaged length. E-Cam will disengage after rotating one cycle at forward direction. Users have to set P5-88.U to 2, 4, and 6; otherwise, the E-cam will not disengage.

E-Cam will disengage when alarm occurs or the power supply is cut off. If users desire E-Cam to re-engage at the last disengaged position and continue its operation, it is recommended to record the disengaged position (X) and resume the operation by this macro command. Please note that when E-Cam is disengaged, the servo position might slightly shift and therefore cause position error when E-Cam re-engages again.

The Engaged direction is in forward direction (Master axis operates at forward direction):

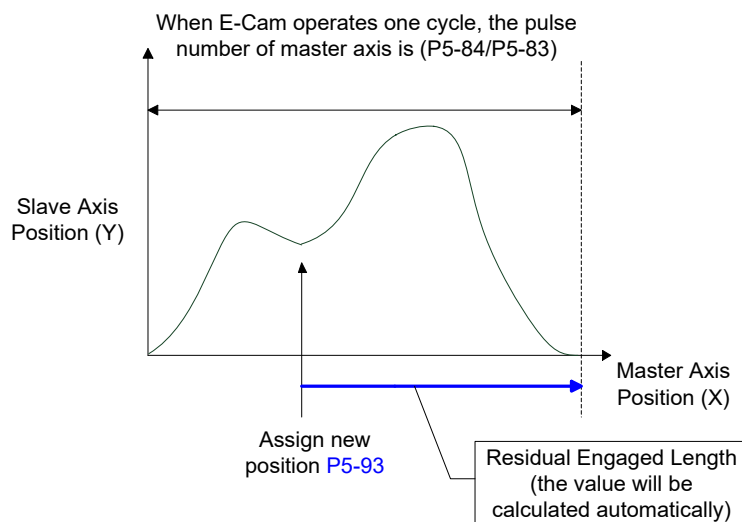

Note: When using this macro command, it would be better to execute this command before operate the master axis.

Failure code 0xF0C1	<p>When executing this macro command, E-Cam is not in engaged status.</p> <p>To modify the engaged position only when E-Cam is</p>
------------------------	--

	engaged.
Failure code 0xF0C2	The setting value of P5-93 is in error. The value cannot less than 0. It should $> = 0$.
Failure code 0xF0C3	The setting value of P5-93 is in error. The value has to less than the value of (P5-84 / P5-83)

The following macros are available from version V1.038 sub48 (included):

Command code 0x000D	Calculate the error between E-Cam and indexing coordinates for PR positioning.
General Parameters	N/A
Macro Parameters	<p>P5-93.Low_Word = DCBA: UZYX (8 digits, HEXADECIMAL) YX (PR number) = 0~0x3F (it is invalid when the value is set to 0) UZ: The value has to be set to 0. BA (Function of P5-95): 0 (Use avoid point) · 1 (Use available forward rate, V1.038 sub53) DC (Inhibit reverse rotation): 0 (invalid), 1(Inhibit reverse rotation, V1.038 sub53) P5-95: Avoid point (cannot pass this point) = 0 ~ 100 (%) of E-Cam cycle or available forward rate 0 ~ 100 (%)</p>
Monitoring variable 091(5Bh): It displays the current indexing coordinate position (PUU)	
<p>When E-Cam is engaged, and the motor is stopped because of Servo Off or alarm occurs, it would cause position error between the actual position and E-Cam position. After re-servo On, this macro command can be used to calculate the correction value and write the value into the specified PR for incremental positioning. So that the motor can return to the ideal E-Cam position.</p> <p>When using this macro command:</p> <ol style="list-style-type: none"> 1. P5-88.X1 = 1 to make E-Cam keep engaging when servo off and continue to calculate E-Cam position. 2. The height of indexing coordinate and E-Cam coordinate should be the same: P2-52= ECAM_H (The moving distance when E-cam operates one cycle) 3. E-Cam table scaling (P5-19) must be 1.0 time. 4. When E-Cam is engaged for the first time, 0 degree of E-cam should aim at 0 degree of indexing coordinate. 5. This macro command only can be applicable on periodic cycle and when every cycle starts from the same position. 	

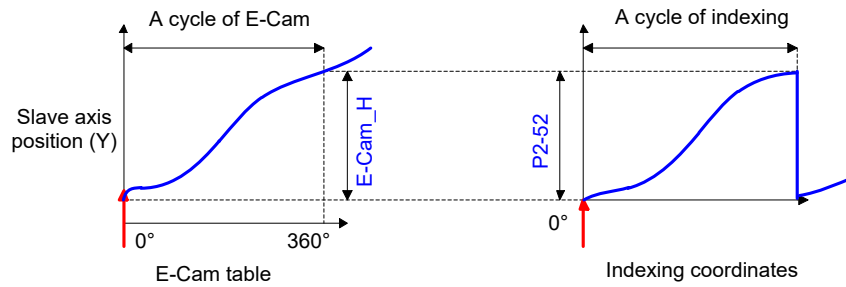



Note 1: ECAM_H (height of E-Cam table) = E-Cam table (last point - first points)

Note 2: Indexing coordinate = (absolute coordinates / P2-52) take remainder.

Note 3: Use PR command for incremental positioning control.

When motor moves from the current position to the target position, it can operate at forward or reverse direction. Due to the cyclic operation, the motor will travel to the specified position either at forward or reverse direction. However, the moving distance is different between both. Uses avoid point to plan the timing of forward and reverse rotation.

* **Avoid point:** the point that cannot be passed by the planned PR.

-  E-Cam current position
-  E-Cam current position
-  E-Cam avoid point Θ , which is set by P5-95

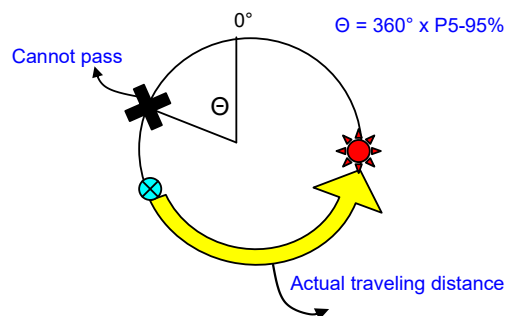

Failure code 0xF0D1	E-Cam is not engaged when executing this macro command. E-Cam should be engaged.
Failure code 0xF0D2	The value of P5-93.YX (PR number) exceeds the range: 1 ~ 0x3F
Failure code 0xF0D3	The value of P5-95 (available forward rate) exceeds the range: 0 ~ 100 (%)
Failure code 0xF0D5	The position correction value does not exist. This macro command might be triggered twice.
Failure code 0xF0D6	When re-servo On, E-cam is not engaged.
Failure code 0xF0D7	The height (Y axis) of E-Cam table is not equal to the value of P2-52.
Failure code 0xF0D8	P5-19 is not equal to 1
Failure code 0xF0D9	P5-93.BA, P5-95 exceeds the range: 0 ~ 1
Failure code	The setting value of P5-93.DC (reverse inhibit) exceeds the

0xF0DA	range: 0 ~ 1
Failure code 0xF0DB	The function of reverse inhibit has failed. Do not use macro command #D, #10h consecutively.

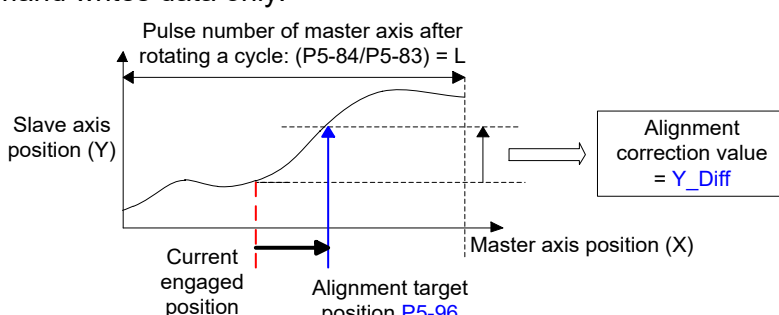

The following macros are provided after version V1.038 sub26 (included):

Command code 0x000E	Perform E-Cam alignment immediately and write the correction value into the specified PR.
Macro parameters	<p>P5-93 = DCBA : UZYX (8 digits, HEXADECIMAL) YX (PR number) = 0 ~ 0x3F, it is invalid when the value is set to 0. UZ (Max. alignment correction rate) = 0 ~ 0x64 (%) A (Trigger the specified PR directly) = 1: On, 0: Off DCB = has to be set to 0 P5-94 (DI delay time compensation) = -25000 ~ +25000; Unit: usec. P5-95 (available forward rate) = 0 ~ 100 (%) P5-96 (target position of alignment X); Unit: pulse number of master axis = 0 ~ (P5-84/P5-83) – 1.</p>
Monitoring variable 062(3Eh): It displays the current engaged position of master axis (X)	
<p>This macro command can move the engaged position to the alignment target position (X) when E-Cam is engaged, and write the alignment correction value into the specified PR.</p> <p>During E-Cam operation (When E-Cam is engaged), if desire to quickly align the E-cam position to the mechanical referral point, sensor can be used to trigger DI.EVx to execute this macro command.</p> <p>After E-Cam alignment is completed, the engaged position will move to the new position. The excess or not enough moving distance after E-Cam operates one cycle is called alignment correction value. It will be written into PR specified by P5-93.YX. PR incremental command can be used to compensate this value so that the slave axis position will remain and offset the phase of E-Cam to align the referral position of machine. For some applications, set value of P5-93.YX to 0 will do. Please note that PR can be executed only when triggering the host controller. This macro command writes data only.</p>	
	
<p>* P5-93.UZ is able to limit the max. correction rate. The alignment target position ★ will be different from P5-96. $\text{alignment target position} \star - \text{current engaged position} / L \leq \text{P5-93.UZ} \%$</p> <p>* DI time delay compensation can be set via P5-94, it can correct the error caused</p>	

by different speed of motion.

When E-Cam moves from current position to the target one, it can rotate at forward or reverse position. Due to the cyclic operation, it can reach the target position either at forward or reverse direction. However, the moving distance between both is usually different. Use available forward rate to plan the timing of forward and reverse rotation.

* Available forward rate: The available max. proportion of forward path

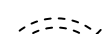
-  E-Cam current position
-  Max. forward rotation limit. Counterclockwise represents forward direction in the figure
-  Target position is within the range; going trip is at forward direction
-  Target position is within the range; going trip is at reverse direction

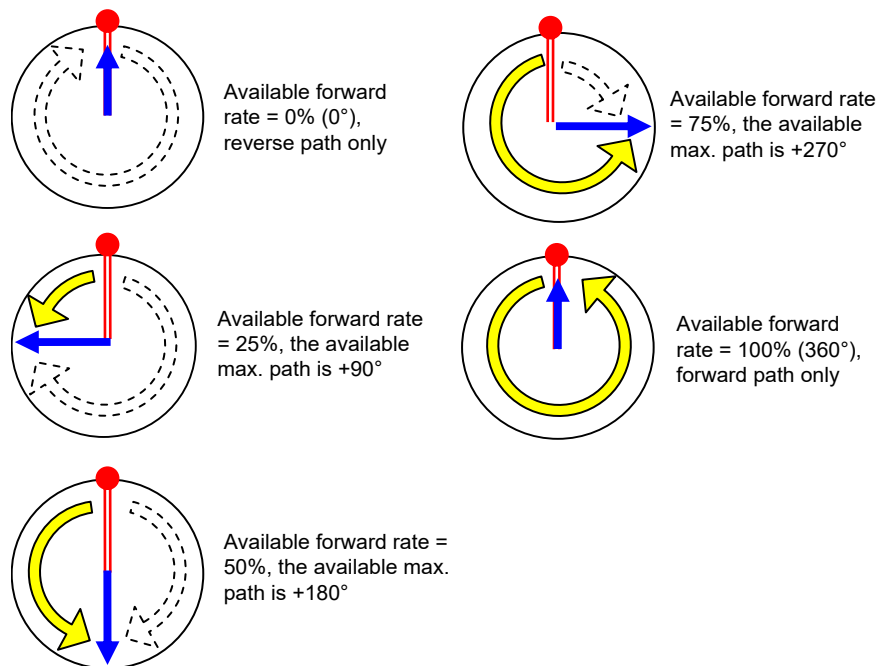

Failure code 0xF0E1	When executing this macro, E-Cam is not engaged. E-Cam has to engage to execute alignment correction.
Failure code 0xF0E2	The setting value of P5-93.YX (PR number) exceeds the range: 0 ~ 0x003F
Failure code 0xF0E3	The setting value of P5-93.UZ (Max. alignment correction rate) exceeds the range: 0~0x0064 (%)
Failure code 0xF0E4	The setting value of P5-94 (DI delay time compensation) exceeds the range: -10000 ~ +10000
Failure code 0xF0E5	The setting value of P5-95 (Available forward rate) exceeds the range: 0 ~ 100 (%)
Failure code 0xF0E6	The setting value of P5-96 (alignment target position) exceeds the range: 0 ~ (P5-84/P5-83) - 1

The following macros are available from version V1.038 sub26 (included):

Command code 0x000F	Calculate the moving distance between current and target position of E-Cam for PR positioning.
General parameters	N/A
Macro parameters	<p>P5-93.Low_Word = UZYX (4 digits, HEXADECIMAL) YX (PR number of going trip) = 0~0x3F, it is invalid if the value is set to 0. UZ (PR number of return trip) = 0~0x3F, it is invalid if the value is set to 0. P5-93.Hi_Word = it has to be set to 0 P5-95 (Available forward rate) = 0 ~ 100 (%) P5-96 (target position X); Unit: pulse number of master axis = 0 ~ (P5-84/P5-83) - 1</p>
Monitoring variable 062(3Eh): It displays the current engaged position (X) of master axis (X)	

This macro command calculates the moving distance between current and target engaged position (X) and writes into the specified PR.

During E-Cam operation, if users desire to move the slave axis to the specified position when master axis stops and still in engaged status, this macro command can calculates the correct moving distance (Y_Drift) of going trip for PR positioning.

When master axis resumes the operation, use another PR to run the moving distance of return trip (-Y_Drift), it can back to the original position (moving distance of going trip + moving distance of return trip = 0). E-Cam position remains the same.

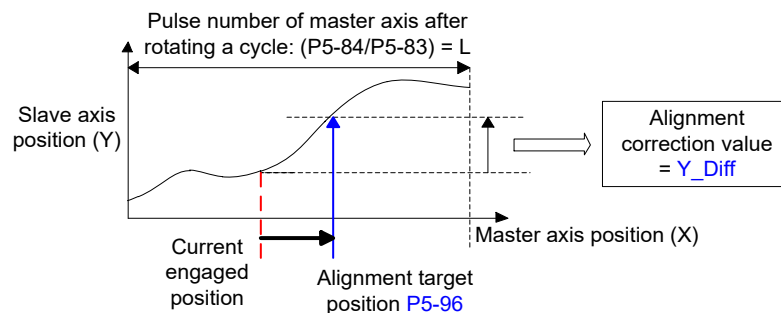

Note: PR command must be the incremental command, regardless in going trip or return trip.

When E-Cam moves from current position to the target one, it can rotate at forward or reverse position. Due to the cyclic operation, it can reach the target position either at forward or reverse direction. However, the moving distance between both is usually different. Use available forward rate to plan the timing of forward and reverse rotation.

* Available forward rate: The available max. proportion of forward path

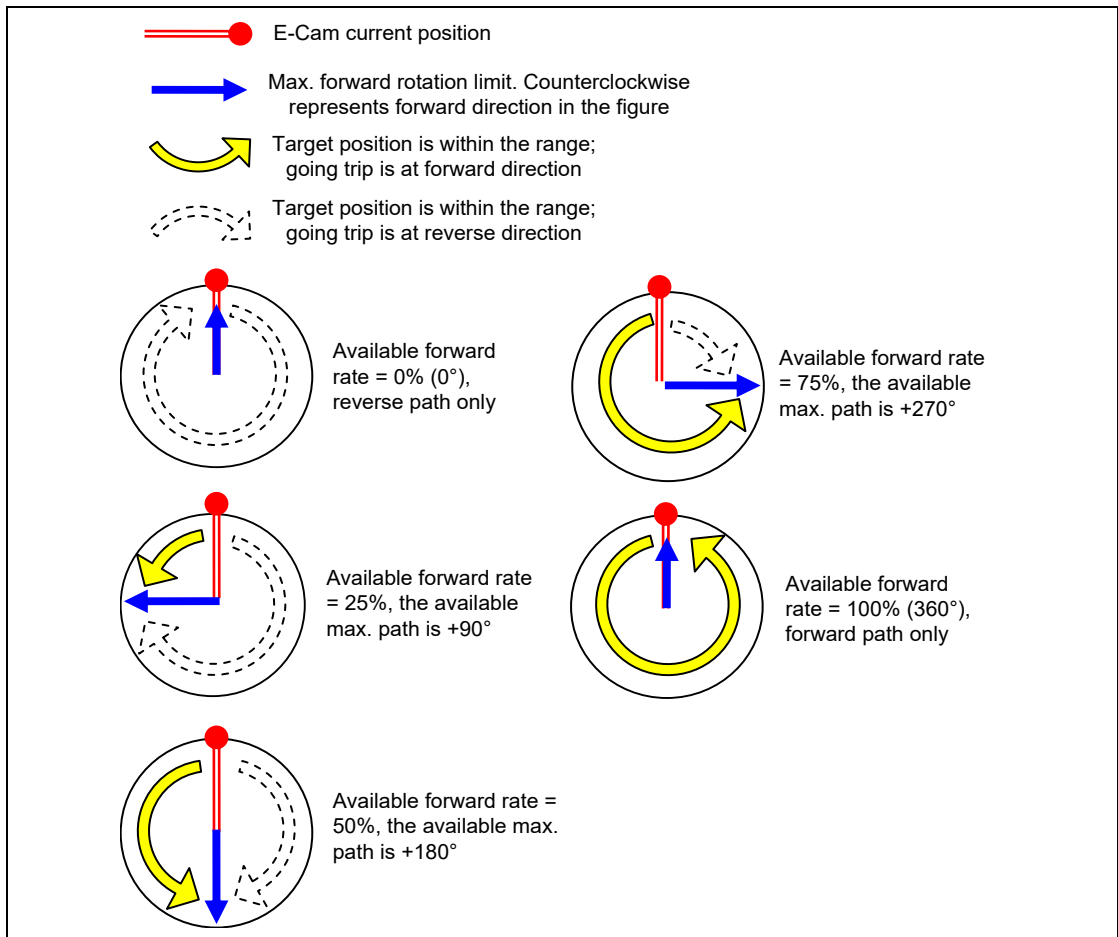

Failure code 0xF0F1	When executing this macro, E-Cam is not engaged. E-Cam has to engage to change the engaged position.
Failure code 0xF0F2	The setting value of P5-93.YX (PR number of going trip) exceeds the range: 0x0000 ~ 0x003F
Failure code 0xF0F3	The setting value of P5-93.UZ (PR number of return trip) exceeds the range: 0x0000 ~ 0x003F
Failure code 0xF0F5	The setting value of P5-95 (Available forward rate) exceeds the range: 0 ~ 100 (%)
Failure code 0xF0F6	The setting value of P5-96 (target position) exceeds the range: 0 ~ (P5-84/P5-83) - 1

The following macros are available from version V1.042 sub09 (included):

Command code 0010h	E-Cam stops for one cycle and resumes its operation at next cycle.
General parameters	N/A
Macro parameters	Value of P5-93 has to be set to 0.

After E-Cam is engaged, this macro command can stop the slave axis for a cycle of distance regardless the E-Cam degree.

The following conditions have to be established when using this macro command.

1. E-Cam must be in engaged status.
2. E-Cam must be the forward operation curve (including straight line) so it can stop temporarily.

Refer to the figure below, triggering this macro command, E-Cam will stop for one cycle regardless the degree (X) where E-Cam is.

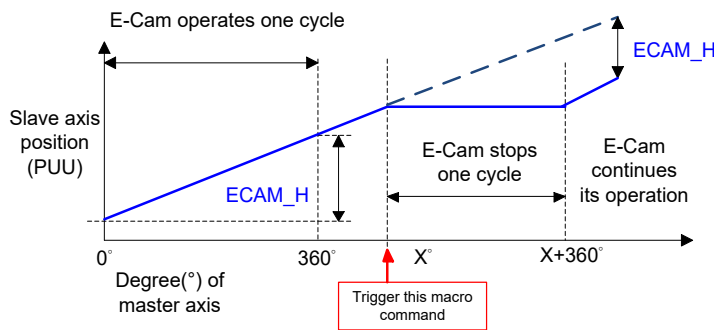

Note 1: $ECAM_H$ (E-Cam pause distance) = table (last point – first point) x P5-19 (the effective scaling)

Note 2: This function can accumulate times. If the command is triggered for N times consecutively, it will stop the E-Cam for N cycles. The accumulated pause distance cannot exceed ($>2^{31}$), or the macro command will be disabled.

Note 3: When E-Cam resumes the operation, the accumulated pause distance will be cleared to 0.

Failure code 0xF101	When executing this macro command, E-Cam is not engaged.
Failure code 0xF102	The setting value of P5-93 is incorrect: It has to be set to 0.
Failure code 0xF103	E-Cam has to operate at forward direction. Please check the E-Cam table and make sure P5-19 > 0.
Failure code 0xF104	The accumulated pause distance exceeds 2^{31} . Do not execute this macro command consecutively.

Note: A2-L does not support E-Cam function.

P5-98	EVON	PR# Triggered by Event Rising-Edge		Address: 05C4H 05C5H
	Operational Interface :	Panel / Software	Communication	Related Section: -
	Default :	0x0000		
	Control Mode :	PR		
	Unit :	-		
	Range :	0x0000 ~ 0xDDDD		
	Data Size :	16-bit		
	Format :	Hexadecimal		

Settings : Four items: UZYX
 When EVx is set to ON, the PR# will be executed.
 X=0: When EV1 is ON, PR will not be triggered.
 X=1 ~ D: When EV1 is ON, execute PR # 51 ~ 63.
 Y=0: When EV2 is ON, PR will not be triggered.
 Y=1 ~ D: When EV2 is ON, execute PR # 51 ~ 63.
 Note: EV3 and EV4 are supported after firmware V1.009.

Z=0: When EV3 is ON, PR will not be triggered.
 Z=1 ~ D: When EV3 is ON, execute PR # 51 ~ 63.
 U=0: When EV3 is ON, PR will not be triggered.
 U=1 ~ D: When EV4 is ON, execute PR # 51 ~ 63.

P5-99	EVOF	PR# Triggered by Event Falling-Edge		Address: 05C6H 05C7H
	Operational Interface :	Panel / Software	Communication	Related Section: -
	Default :	0x0000		
	Control Mode :	PR		
	Unit :	-		
	Range :	0x0000 ~ 0xDDDD		
	Data Size :	16-bit		
	Format :	Hexadecimal		

Settings : Four items: UZYX
 When EVx is set to OFF, the PR# will be executed.
 X=0: When EV1 is OFF, PR will not be triggered.
 X=1 ~ D: When EV1 is OFF, execute PR # 51 ~ 63.
 Y=0: When EV2 is OFF, PR will not be triggered.
 Y=1 ~ D: When EV2 is OFF, execute PR # 51 ~ 63.
 Note: EV3 and EV4 are supported after firmware V1.009.

Z=0: When EV3 is OFF, PR will not be triggered.
 Z=1 ~ D: When EV3 is OFF, execute PR # 51 ~ 63.
 U=0: When EV4 is OFF, PR will not be triggered.
 U=1 ~ D: When EV4 is OFF, execute PR # 51 ~ 63.

P6-xx PR Parameters (Please refer to Chapter 7 for detailed setting)

P6-00	ODEF	Homing Definition		Address: 0600H 0601H
Operational Interface :	Panel / Software	Communication		Related Section; 7.10
Default :	0x00000000			
Control Mode :	PR			
Unit :	-			
Range :	0x00000000 ~ 0x10FFFF3F			
Data Size :	32-bit			
Format :	Hexadecimal			
Settings :	Homing definition:			

.31 ~ 28	.27 ~ 24	.23 ~20	.19 ~ 16	.15 ~ 12	11 ~ 8	7 ~ 4	3 ~ 0
BOOT	-	DLY	-	DEC1	ACC	PATH	

PATH: Path type (64-bit)

0: Stop: Homing complete and stop

1 ~ 3F: Auto: Homing complete and execute the specified path
(Path#1 ~ Path#63)

ACC: Select 0~F for acceleration time and corresponds to
P5-20~P5-35.

DEC1: The deceleration time selection of 1st homing, the setting value
of DEC is 0 ~ F and corresponds to P5-20 ~ P5-35.

DLY: Select 0 ~ F for the delay time and corresponds to P5-40 ~ P5-55

BOOT: When the servo drive applies to the power, if it will be executed
searching the origin.

0: Do not do homing

1: Execute homing automatically (SRV ON for the first time
after applying to power)

Apart from the above mentioned definition, the related setting of
homing also includes:

1. P5-04 Homing mode
2. P5-05 ~ P5-06 Speed setting of searching the origin
3. P6-01: ORG_DEF is the location of the origin. It may not be 0.
This function is the offset of coordinate system.

A. The setting for whether to return to the origin after completing
homing of P1-47 in the A series is not available in the A2 series;
instead, it is done in other ways. After the origin is found (Sensor or
Z); it has to decelerate to stop. The stop position will exceed the

origin for a short distance.

If it does not return to the origin, set PATH to 0.

If it needs to return to the origin, set PATH to non-zero value and set PABS = ORG_DEF.

- B. If the origin is found (Sensor or Z), desire to move an offset S and define the coordinate as P after moving, then PATH = non-zero and set ORG_DEF = P-S. The absolute position command = P.

P6-01	ODAT	Origin Definition						Address: 0602H 0603H								
	Operational Interface :	Panel / Software			Communication			Related Section: 7.10								
	Default :	0														
	Control Mode :	PR														
	Unit :	-														
	Range :	-2147483648 ~ +2147483647														
	Data Size :	32-bit														
	Format :	Decimal														
	Settings :	Value of origin definition:														
	.31 ~ 28		.27 ~ 24		.23 ~ 20		.19 ~ 16			.15 ~ 12		11 ~ 8		7 ~ 4		3 ~ 0
	ORG_DEF (32-bit)															

P6-02	PDEF1	PATH#1 Definition						Address: 0604H 0605H		
	Operational Interface :	Panel / Software			Communication			Related Section: 7.10		
	Default :	0x00000000								
	Control Mode :	PR								
	Unit :	-								
	Range :	0x00000000 ~ 0xFFFFFFFF								
	Data Size :	32-bit								
	Format :	Hexadecimal								

Settings : Properties of PATH# 1:

	.31 ~ 28	.27 ~ 24	.23 ~ 20	.19 ~ 16	.15 ~ 12	11 ~ 8	7 ~ 4	3 ~ 0
P6-02	-	-	DLY	-	-	-	OPT	TYPE
P6-03	DATA (32-bit)							

TYPE, OPT:

OPT				TYPE
7	6	5	4 BIT	3 ~ 0 BIT
-	UNIT	AUTO	INS	1: SPEED, Speed setting control
CMD		OVLP	INS	2: SINGLE, Positioning control. It will load in the next path when finished. 3: AUTO positioning control. It will load in the next path when finished.
-	-	-	INS	7: JUMP to the specified path
-	-	AUTO	INS	8: Write the specified parameter to the specified path

TYPE: 1 ~ 3 accept DI.STP stop and software limit.

INS: When executing this PR, it interrupts the previous one.

OVLP: Allow the overlap of the next path. The overlap is not allowed in speed mode. When overlap happens in position mode, DLY has no function.

AUTO: When PR procedure completes, the next procedure will be loaded in automatically.

CMD: Refer to Chapter 7 for PR command description.

DLY: 0 ~ F, delay time number (4 BIT). The delay after executing this PR. The external INS is invalid.

DLY (4) Index P5-40 ~ P5-55

P6-03	PDAT1	PATH# 1 Data	Address: 0606H 0607H
	Operational Interface :	Panel / Software Communication	Related Section: 7.10
	Default :	0	
	Control Mode :	PR	
	Unit :	-	
	Range :	-2147483648 ~ +2147483647	
	Data Size :	32-bit	
	Format :	Decimal	

Settings : PATH# 1 Data

.31 ~ 28	.27 ~ 24	.23 ~20	.19 ~ 16	.15 ~ 12	11 ~ 8	7 ~ 4	3 ~ 0
DATA (32 bit)							

Property of P6-02; P6-03 corresponds to the target position of P6-02 or jump to PATH_NO.

Note: PATH (procedure)

P6-04	PDEF2	PATH# 2 Definition		Address: 0608H 0609H
	Operational Interface :	Panel / Software	Communication	Related Section: 7.10
	Default :	0x00000000		
	Control Mode :	PR		
	Unit :	-		
	Range :	0x00000000 ~ 0xFFFFFFFF		
	Data Size :	32-bit		
	Format :	Hexadecimal		

Settings : Please refer to the description of P6-02.

P6-05	PDAT2	PATH# 2 Data		Address: 060AH 060BH
	Operational Interface :	Panel / Software	Communication	Related Section: 7.10
	Default :	0		
	Control Mode :	PR		
	Unit :	-		
	Range :	-2147483648 ~ +2147483647		
	Data Size :	32-bit		
	Format :	Decimal		

Settings : Please refer to the description of P6-03.

P6-06	PDEF3	PATH# 3 Definition		Address: 060CH 060DH
	Operational Interface :	Panel / Software	Communication	Related Section: 7.10
	Default :	0x00000000		
	Control Mode :	PR		
	Unit :	-		
	Range :	0x00000000 ~ 0xFFFFFFFF		
	Data Size :	32-bit		
	Format :	Hexadecimal		

Settings : Please refer to the description of P6-02.

P6-07	PDAT3	PATH# 3 Data		Address: 060EH 060FH
	Operational Interface :	Panel / Software	Communication	Related Section: 7.10
	Default :	0		
	Control Mode :	PR		
	Unit :	-		
	Range :	-2147483648 ~ +2147483647		
	Data Size :	32-bit		
	Format :	Decimal		

Settings : Please refer to the description of P6-03.

P6-08	PDEF4	PATH# 4 Definition		Address: 0610H 0611H
	Operational Interface :	Panel / Software	Communication	Related Section: 7.10
	Default :	0x00000000		
	Control Mode :	PR		
Unit :	-			

Range :	0x00000000 ~ 0xFFFFFFFF
Data Size :	32-bit
Format :	Hexadecimal

Settings : Please refer to the description of P6-02.

P6-09	PDAT4	PATH# 4 Data		Address: 0612H 0613H
	Operational Interface :	Panel / Software	Communication	Related Section: 7.10
	Default :	0		
	Control Mode :	PR		
	Unit :	-		
	Range :	-2147483648 ~ +2147483647		
	Data Size :	32-bit		
	Format :	Decimal		

Settings : Please refer to the description of P6-03.

P6-10	PDEF5	PATH# 5 Definition		Address: 0614H 0615H
	Operational Interface :	Panel / Software	Communication	Related Section: 7.10
	Default :	0x00000000		
	Control Mode :	PR		
	Unit :	-		
	Range :	0x00000000 ~ 0xFFFFFFFF		
	Data Size :	32-bit		
	Format :	Hexadecimal		

Settings : Please refer to the description of P6-02.

P6-11	PDAT5	PATH# 5 Data		Address: 0616H 0617H
	Operational Interface :	Panel / Software	Communication	Related Section: 7.10
	Default :	0		
	Control Mode :	PR		
	Unit :	-		
	Range :	-2147483648 ~ +2147483647		
	Data Size :	32-bit		
	Format :	Decimal		

Settings : Please refer to the description of P6-03.

P6-12	PDEF6	PATH# 6 Definition		Address: 0618H 0619H
	Operational Interface :	Panel / Software	Communication	Related Section: 7.10
	Default :	0x00000000		
	Control Mode :	PR		
	Unit :	-		
	Range :	0x00000000 ~ 0xFFFFFFFF		
	Data Size :	32-bit		
	Format :	Hexadecimal		

Settings : Please refer to the description of P6-02.

P6-13	PDAT6	PATH# 6 Data		Address: 061AH 061BH
	Operational Interface :	Panel / Software	Communication	Related Section: 7.10
	Default :	0		
	Control Mode :	PR		
	Unit :	-		

Range :	-2147483648 ~ +2147483647
Data Size :	32-bit
Format :	Decimal

Settings : Please refer to the description of P6-03.

P6-14	PDEF7	PATH# 7 Definition		Address: 061CH 061DH
	Operational Interface :	Panel / Software	Communication	Related Section: 7.10
Default :	0x00000000			
Control Mode :	PR			
Unit :	-			
Range :	0x00000000 ~ 0xFFFFFFFF			
Data Size :	32-bit			
Format :	Hexadecimal			

Settings : Please refer to the description of P6-02.

P6-15	PDAT7	PATH# 7 Data		Address: 061EH 061FH
	Operational Interface :	Panel / Software	Communication	Related Section: 7.10
Default :	0			
Control Mode :	PR			
Unit :	-			
Range :	-2147483648 ~ +2147483647			
Data Size :	32-bit			
Format :	Decimal			

Settings : Please refer to the description of P6-03.

P6-16	PDEF8	PATH# 8 Definition		Address: 0620H 0621H
	Operational Interface :	Panel / Software	Communication	Related Section: 7.10
	Default :	0x00000000		
	Control Mode :	PR		
	Unit :	-		
	Range :	0x00000000 ~ 0xFFFFFFFF		
	Data Size :	32-bit		
	Format :	Hexadecimal		

Settings : Please refer to the description of P6-02.

P6-17	PDAT8	PATH# 8 Data		Address: 0622H 0623H
	Operational Interface :	Panel / Software	Communication	Related Section: 7.10
	Default :	0		
	Control Mode :	PR		
	Unit :	-		
	Range :	-2147483648 ~ +2147483647		
	Data Size :	32-bit		
	Format :	Decimal		

Settings : Please refer to the description of P6-03.

P6-18	PDEF9	PATH# 9 Definition		Address: 0624H 0625H
	Operational Interface :	Panel / Software	Communication	Related Section: 7.10
	Default :	0x00000000		
	Control Mode :	PR		
Unit :	-			

Range :	0x00000000 ~ 0xFFFFFFFF
Data Size :	32-bit
Format :	Hexadecimal

Settings : Please refer to the description of P6-02.

P6-19	PDAT9	PATH# 9 Data	Address: 0626H 0627H
	Operational Interface :	Panel / Software	Communication
	Default :	0	
	Control Mode :	PR	
	Unit :	-	
	Range :	-2147483648 ~ +2147483647	
	Data Size :	32-bit	
	Format :	Decimal	

Related Section:
7.10

Settings : Please refer to the description of P6-03.

P6-20	PDEF10	PATH# 10 Definition	Address: 0628H 0629H
	Operational Interface :	Panel / Software	Communication
	Default :	0x00000000	
	Control Mode :	PR	
	Unit :	-	
	Range :	0x00000000 ~ 0xFFFFFFFF	
	Data Size :	32-bit	
	Format :	Hexadecimal	

Related Section:
7.10

Settings : Please refer to the description of P6-02.

P6-21	PDAT10	PATH# 10 Data		Address: 062AH 062BH
	Operational Interface :	Panel / Software	Communication	Related Section: 7.10
	Default :	0		
	Control Mode :	PR		
	Range :	-2147483648 ~ +2147483647		
	Data Size :	32-bit		
	Format :	Decimal		

Settings : Please refer to the description of P6-03.

P6-22	PDEF11	PATH# 11 Definition		Address: 062CH 062DH
	Operational Interface :	Panel / Software	Communication	Related Section: 7.10
	Default :	0x00000000		
	Control Mode :	PR		
	Unit :	-		
	Range :	0x00000000 ~ 0xFFFFFFFF		
	Data Size :	32-bit		
Format :	Hexadecimal			

Settings : Please refer to the description of P6-02.

P6-23	PDAT11	PATH# 11 Data		Address: 062EH 062FH
	Operational Interface :	Panel / Software	Communication	Related Section: 7.10
	Default :	0		
	Control Mode :	PR		
	Unit :	-		
	Range :	-2147483648 ~ +2147483647		

Data Size :	32-bit
Format :	Decimal

Settings : Please refer to the description of P6-03.

P6-24	PDEF12	PATH# 12 Definition		Address: 0630H 0631H
	Operational Interface :	Panel / Software	Communication	Related Section: 7.10
Default :	0x00000000			
Control Mode :	PR			
Unit :	-			
Range :	0x00000000 ~ 0xFFFFFFFF			
Data Size :	32-bit			
Format :	Hexadecimal			

Settings : Please refer to the description of P6-02.

P6-25	PDAT12	PATH# 12 Data		Address: 0632H 0633H
	Operational Interface :	Panel / Software	Communication	Related Section: 7.10
Default :	0			
Control Mode :	PR			
Unit :	-			
Range :	-2147483648 ~ +2147483647			
Data Size :	32-bit			
Format :	Decimal			

Settings : Please refer to the description of P6-03.

P6-26	PDEF13	PATH# 13 Definition		Address: 0634H 0635H
	Operational Interface :	Panel / Software	Communication	Related Section: 7.10
	Default :	0x00000000		
	Control Mode :	PR		
	Unit :	-		
	Range :	0x00000000 ~ 0xFFFFFFFF		
	Data Size :	32-bit		
	Format :	Hexadecimal		

Settings : Please refer to the description of P6-02.

P6-27	PDAT13	PATH# 13 Data		Address: 0636H 0637H
	Operational Interface :	Panel / Software	Communication	Related Section: 7.10
	Default :	0		
	Control Mode :	PR		
	Unit :	-		
	Range :	-2147483648 ~ +2147483647		
	Data Size :	32-bit		
	Format :	Decimal		

Settings : Please refer to the description of P6-03.

P6-28	PDEF14	PATH# 14 Definition		Address: 0638H 0639H
	Operational Interface :	Panel / Software	Communication	Related Section: 7.10
	Default :	0x00000000		
	Control Mode :	PR		
	Unit :	-		

Range :	0x00000000 ~ 0xFFFFFFFF
Data Size :	32-bit
Format :	Hexadecimal

Settings : Please refer to the description of P6-02.

P6-29	PDAT14	PATH# 14 Data		Address: 063AH 063BH
	Operational Interface :	Panel / Software	Communication	Related Section: 7.10
	Default :	0		
	Control Mode :	PR		
	Unit :	-		
	Range :	-2147483648 ~ +2147483647		
	Data Size :	32-bit		
	Format :	Decimal		

Settings : Please refer to the description of P6-03.

P6-30	PDEF15	PATH# 15Definition		Address: 063CH 063DH
	Operational Interface :	Panel / Software	Communication	Related Section: 7.10
	Default :	0x00000000		
	Control Mode :	PR		
	Unit :	-		
	Range :	0x00000000 ~ 0xFFFFFFFF		
	Data Size :	32-bit		
	Format :	Hexadecimal		

Settings : Please refer to the description of P6-02.

P6-31	PDAT15	PATH# 15 Data		Address: 063EH 063FH
	Operational Interface :	Panel / Software	Communication	Related Section: 7.10
	Default :	0		
	Control Mode :	PR		
	Unit :	-		
	Range :	-2147483648 ~ +2147483647		
	Data Size :	32-bit		
	Format :	Decimal		

Settings : Please refer to the description of P6-03.

P6-32	PDEF16	PATH# 16 Definition		Address: 0640H 0641H
	Operational Interface :	Panel / Software	Communication	Related Section: 7.10
	Default :	0x00000000		
	Control Mode :	PR		
	Unit :	-		
	Range :	0x00000000 ~ 0xFFFFFFFF		
	Data Size :	32-bit		
	Format :	Hexadecimal		

Settings : Please refer to the description of P6-02.

P6-33	PDAT16	PATH# 16 Data		Address: 0642H 0643H
	Operational Interface :	Panel / Software	Communication	Related Section: 7.10
	Default :	0		
	Control Mode :	PR		
	Unit :	-		

Range :	-2147483648 ~ +2147483647
Data Size :	32-bit
Format :	Decimal

Settings : Please refer to the description of P6-03.

P6-34	PDEF17	PATH# 17 Definition	Address: 0644H 0645H
Operational Interface :	Panel / Software	Communication	Related Section: 7.10
Default :	0x00000000		
Control Mode :	PR		
Unit :	-		
Range :	0x00000000 ~ 0xFFFFFFFF		
Data Size :	32-bit		
Format :	Hexadecimal		

Settings : Please refer to the description of P6-02.

P6-35	PDAT17	PATH# 17 Data	Address: 0646H 0647H
Operational Interface :	Panel / Software	Communication	Related Section: 7.10
Default :	0		
Control Mode :	PR		
Unit :	-		
Range :	-2147483648 ~ +2147483647		
Data Size :	32-bit		
Format :	Decimal		

Settings : Please refer to the description of P6-03.

P6-36	PDEF18	PATH# 18 Definition		Address: 0648H 0649H
	Operational Interface :	Panel / Software	Communication	Related Section: 7.10
	Default :	0x00000000		
	Control Mode :	PR		
	Unit :	-		
	Range :	0x00000000 ~ 0xFFFFFFFF		
	Data Size :	32-bit		
	Format :	Hexadecimal		

Settings : Please refer to the description of P6-02.

P6-37	PDAT18	PATH# 18 Data		Address: 064AH 064BH
	Operational Interface :	Panel / Software	Communication	Related Section: 7.10
	Default :	0		
	Control Mode :	PR		
	Unit :	-		
	Range :	-2147483648 ~ +2147483647		
	Data Size :	32-bit		
	Format :	Decimal		

Settings : Please refer to the description of P6-03.

P6-38	PDEF19	PATH# 19 Definition		Address: 064CH 064DH
	Operational Interface :	Panel / Software	Communication	Related Section: 7.10
	Default :	0x00000000		
	Control Mode :	PR		
	Unit :	-		

Range :	0x00000000 ~ 0xFFFFFFFF
Data Size :	32-bit
Format :	Hexadecimal

Settings : Please refer to the description of P6-02.

P6-39	PDAT19	PATH# 19 Data		Address: 064EH 064FH
	Operational Interface :	Panel / Software	Communication	Related Section: 7.10
	Default :	0		
	Control Mode :	PR		
	Unit :	-		
	Range :	-2147483648 ~ +2147483647		
	Data Size :	32-bit		
	Format :	Decimal		

Settings : Please refer to the description of P6-03.

P6-40	PDEF20	PATH# 20 Definition		Address: 0650H 0651H
	Operational Interface :	Panel / Software	Communication	Related Section: 7.10
	Default :	0x00000000		
	Control Mode :	PR		
	Unit :	-		
	Range :	0x00000000 ~ 0xFFFFFFFF		
	Data Size :	32-bit		
	Format :	Hexadecimal		

Settings : Please refer to the description of P6-02.

P6-41	PDAT20	PATH# 20 Data		Address: 0652H 0653H
	Operational Interface :	Panel / Software	Communication	Related Section: 7.10
	Default :	0		
	Control Mode :	PR		
	Unit :	-		
	Range :	-2147483648 ~ +2147483647		
	Data Size :	32-bit		
	Format :	Decimal		

Settings : Please refer to the description of P6-03.

P6-42	PDEF21	PATH# 21 Definition		Address: 0654H 0655H
	Operational Interface :	Panel / Software	Communication	Related Section: 7.10
	Default :	0x00000000		
	Control Mode :	PR		
	Unit :	-		
	Range :	0x00000000 ~ 0xFFFFFFFF		
	Data Size :	32-bit		
	Format :	Hexadecimal		

Settings : Please refer to the description of P6-02.

P6-43	PDAT21	PATH# 21 Data		Address: 0656H 0657H
	Operational Interface :	Panel / Software	Communication	Related Section: 7.10
	Default :	0		
	Control Mode :	PR		
	Unit :	-		

Range :	-2147483648 ~ +2147483647
Data Size :	32-bit
Format :	Decimal

Settings : Please refer to the description of P6-03.

P6-44	PDEF22	PATH# 22 Definition		Address: 0658H 0659H
	Operational Interface :	Panel / Software	Communication	Related Section: 7.10
Default :	0x00000000			
Control Mode :	PR			
Unit :	-			
Range :	0x00000000 ~ 0xFFFFFFFF			
Data Size :	32-bit			
Format :	Hexadecimal			

Settings : Please refer to the description of P6-02.

P6-45	PDAT22	PATH# 22 Data		Address: 065AH 065BH
	Operational Interface :	Panel / Software	Communication	Related Section: 7.10
Default :	0			
Control Mode :	PR			
Unit :	-			
Range :	-2147483648 ~ +2147483647			
Data Size :	32-bit			
Format :	Decimal			

Settings : Please refer to the description of P6-03.

P6-46	PDEF23	PATH# 23 Definition		Address: 065CH 065DH
	Operational Interface :	Panel / Software	Communication	Related Section: 7.10
	Default :	0x00000000		
	Control Mode :	PR		
	Unit :	-		
	Range :	0x00000000 ~ 0xFFFFFFFF		
	Data Size :	32-bit		
	Format :	Hexadecimal		

Settings : Please refer to the description of P6-02.

P6-47	PDAT23	PATH# 23 Data		Address: 065EH 065FH
	Operational Interface :	Panel / Software	Communication	Related Section: 7.10
	Default :	0		
	Control Mode :	PR		
	Unit :	-		
	Range :	-2147483648 ~ +2147483647		
	Data Size :	32-bit		
	Format :	Decimal		

Settings : Please refer to the description of P6-03.

P6-48	PDEF24	PATH# 24 Definition		Address: 0660H 0661H
	Operational Interface :	Panel / Software	Communication	Related Section: 7.10
	Default :	0x00000000		
	Control Mode :	PR		
Unit :	-			

Range :	0x00000000 ~ 0xFFFFFFFF
Data Size :	32-bit
Format :	Hexadecimal

Settings : Please refer to the description of P6-02.

P6-49	PDAT24	PATH# 24 Data		Address: 0662H 0663H
	Operational Interface :	Panel / Software	Communication	Related Section: 7.10
	Default :	0		
	Control Mode :	PR		
	Unit :	-		
	Range :	-2147483648 ~ +2147483647		
	Data Size :	32-bit		
	Format :	Decimal		

Settings : Please refer to the description of P6-03.

P6-50	PDEF25	PATH# 25 Definition		Address: 0664H 0665H
	Operational Interface :	Panel / Software	Communication	Related Section: 7.10
	Default :	0x00000000		
	Control Mode :	PR		
	Unit :	-		
	Range :	0x00000000 ~ 0xFFFFFFFF		
	Data Size :	32-bit		
	Format :	Hexadecimal		

Settings : Please refer to the description of P6-02.

P6-51	PDAT25	PATH# 25 Data		Address: 0666H 0667H
	Operational Interface :	Panel / Software	Communication	Related Section: 7.10
	Default :	0		
	Control Mode :	PR		
	Unit :	-		
	Range :	-2147483648 ~ +2147483647		
	Data Size :	32-bit		
	Format :	Decimal		

Settings : Please refer to the description of P6-03.

P6-52	PDEF26	PATH# 26 Definition		Address: 0668H 0669H
	Operational Interface :	Panel / Software	Communication	Related Section: 7.10
	Default :	0x00000000		
	Control Mode :	PR		
	Unit :	-		
	Range :	0x00000000 ~ 0xFFFFFFFF		
	Data Size :	32-bit		
	Format :	Hexadecimal		

Settings : Please refer to the description of P6-02.

P6-53	PDAT26	PATH# 26 Data		Address: 066AH 066BH
	Operational Interface :	Panel / Software	Communication	Related Section: 7.10
	Default :	0		
	Control Mode :	PR		
	Unit :	-		

Range :	-2147483648 ~ +2147483647
Data Size :	32-bit
Format :	Decimal

Settings : Please refer to the description of P6-03.

P6-54	PDEF27	PATH# 27 Definition		Address: 066CH 066DH
	Operational Interface :	Panel / Software	Communication	Related Section: 7.10
Default :	0x00000000			
Control Mode :	PR			
Unit :	-			
Range :	0x00000000 ~ 0xFFFFFFFF			
Data Size :	32-bit			
Format :	Hexadecimal			

Settings : Please refer to the description of P6-02.

P6-55	PDAT27	PATH# 27 Data		Address: 066EH 066FH
	Operational Interface :	Panel / Software	Communication	Related Section: 7.10
Default :	0			
Control Mode :	PR			
Unit :	-			
Range :	-2147483648 ~ +2147483647			
Data Size :	32-bit			
Format :	Decimal			

Settings : Please refer to the description of P6-03.

P6-56	PDEF28	PATH# 28 Definition		Address: 0670H 0671H
	Operational Interface :	Panel / Software	Communication	Related Section: 7.10
	Default :	0x00000000		
	Control Mode :	PR		
	Unit :	-		
	Range :	0x00000000 ~ 0xFFFFFFFF		
	Data Size :	32-bit		
	Format :	Hexadecimal		

Settings : Please refer to the description of P6-02.

P6-57	PDAT28	PATH# 28 Data		Address: 0672H 0673H
	Operational Interface :	Panel / Software	Communication	Related Section: 7.10
	Default :	0		
	Control Mode :	PR		
	Unit :	-		
	Range :	-2147483648 ~ +2147483647		
	Data Size :	32-bit		
	Format :	Decimal		

Settings : Please refer to the description of P6-03.

P6-58	PDEF29	PATH# 29 Definition		Address: 0674H 0675H
	Operational Interface :	Panel / Software	Communication	Related Section: 7.10
	Default :	0x00000000		
	Control Mode :	PR		
Unit :	-			

Range :	0x00000000 ~ 0xFFFFFFFF
Data Size :	32-bit
Format :	Hexadecimal

Settings : Please refer to the description of P6-02.

P6-59	PDAT29	PATH# 29 Data		Address: 0676H 0677H
	Operational Interface :	Panel / Software	Communication	Related Section: 7.10
	Default :	0		
	Control Mode :	PR		
	Unit :	-		
	Range :	-2147483648 ~ +2147483647		
	Data Size :	32-bit		
	Format :	Decimal		

Settings : Please refer to the description of P6-03.

P6-60	PDEF30	PATH# 30 Definition		Address: 0678H 0679H
	Operational Interface :	Panel / Software	Communication	Related Section: 7.10
	Default :	0x00000000		
	Control Mode :	PR		
	Unit :	-		
	Range :	0x00000000 ~ 0xFFFFFFFF		
	Data Size :	32-bit		
	Format :	Hexadecimal		

Settings : Please refer to the description of P6-02.

P6-61	PDAT30	PATH# 30 Data		Address: 067AH 067BH
	Operational Interface :	Panel / Software	Communication	Related Section: 7.10
	Default :	0		
	Control Mode :	PR		
	Unit :	-		
	Range :	-2147483648 ~ +2147483647		
	Data Size :	32-bit		
	Format :	Decimal		

Settings : Please refer to the description of P6-03.

P6-62	PDEF31	PATH# 31 Definition		Address: 067CH 067DH
	Operational Interface :	Panel / Software	Communication	Related Section: 7.10
	Default :	0x00000000		
	Control Mode :	PR		
	Unit :	-		
	Range :	0x00000000 ~ 0xFFFFFFFF		
	Data Size :	32-bit		
	Format :	Hexadecimal		

Settings : Please refer to the description of P6-02.

P6-63	PDAT31	PATH# 31 Data		Address: 067EH 067FH
	Operational Interface :	Panel / Software	Communication	Related Section: 7.10
	Default :	0		
	Control Mode :	PR		
	Unit :	-		

Range :	-2147483648 ~ +2147483647
Data Size :	32-bit
Format :	Decimal

Settings : Please refer to the description of P6-03.

P6-64	PDEF32	PATH# 32 Definition		Address: 0680H 0681H
Operational Interface :	Panel / Software	Communication	Related Section: 7.10	
Default :	0x00000000			
Control Mode :	PR			
Unit :	-			
Range :	0x00000000 ~ 0xFFFFFFFF			
Data Size :	32-bit			
Format :	Hexadecimal			

Settings : Please refer to the description of P6-02.

P6-65	PDAT32	PATH# 32 Data		Address: 0682H 0683H
Operational Interface :	Panel / Software	Communication	Related Section: 7.10	
Default :	0			
Control Mode :	PR			
Unit :	-			
Range :	-2147483648 ~ +2147483647			
Data Size :	32-bit			
Format :	Decimal			

Settings : Please refer to the description of P6-03.

P6-66	PDEF33	PATH# 33 Definition		Address: 0684H 0685H
	Operational Interface :	Panel / Software	Communication	Related Section: 7.10
	Default :	0x00000000		
	Control Mode :	PR		
	Unit :	-		
	Range :	0x00000000 ~ 0xFFFFFFFF		
	Data Size :	32-bit		
	Format :	Hexadecimal		

Settings : Please refer to the description of P6-02.

P6-67	PDAT33	PATH# 33 Data		Address: 0686H 0687H
	Operational Interface :	Panel / Software	Communication	Related Section: 7.10
	Default :	0		
	Control Mode :	PR		
	Unit :	-		
	Range :	-2147483648 ~ +2147483647		
	Data Size :	32-bit		
	Format :	Decimal		

Settings : Please refer to the description of P6-03.

P6-68	PDEF34	PATH# 34 Definition		Address: 0688H 0689H
	Operational Interface :	Panel / Software	Communication	Related Section: 7.10
	Default :	0x00000000		
	Control Mode :	PR		
Unit :	-			

Range :	0x00000000 ~ 0xFFFFFFFF
Data Size :	32-bit
Format :	Hexadecimal

Settings : Please refer to the description of P6-02.

P6-69	PDAT34	PATH# 34 Data		Address: 068AH 068BH
	Operational Interface :	Panel / Software	Communication	Related Section: 7.10
	Default :	0		
	Control Mode :	PR		
	Unit :	-		
	Range :	-2147483648 ~ +2147483647		
	Data Size :	32-bit		
	Format :	Decimal		

Settings : Please refer to the description of P6-03.

P6-70	PDEF35	PATH# 35 Definition		Address: 068CH 068DH
	Operational Interface :	Panel / Software	Communication	Related Section: 7.10
	Default :	0x00000000		
	Control Mode :	PR		
	Unit :	-		
	Range :	0x00000000 ~ 0xFFFFFFFF		
	Data Size :	32-bit		
	Format :	Hexadecimal		

Settings : Please refer to the description of P6-02.

P6-71	PDAT35	PATH# 35 Data		Address: 068EH 068FH
	Operational Interface :	Panel / Software	Communication	Related Section: 7.10
	Default :	0		
	Control Mode :	PR		
	Unit :	-		
	Range :	-2147483648 ~ +2147483647		
	Data Size :	32-bit		
	Format :	Decimal		

Settings : Please refer to the description of P6-03.

P6-72	PDEF36	PATH# 36 Definition		Address: 0690H 0691H
	Operational Interface :	Panel / Software	Communication	Related Section: 7.10
	Default :	0x00000000		
	Control Mode :	PR		
	Unit :	-		
	Range :	0x00000000 ~ 0xFFFFFFFF		
	Data Size :	32-bit		
	Format :	Hexadecimal		

Settings : Please refer to the description of P6-02.

P6-73	PDAT36	PATH# 36 Data		Address: 0692H 0693H
	Operational Interface :	Panel / Software	Communication	Related Section: 7.10
	Default :	0		
	Control Mode :	PR		
	Unit :	-		

Range :	-2147483648 ~ +2147483647
Data Size :	32-bit
Format :	Decimal

Settings : Please refer to the description of P6-03.

P6-74	PDEF37	PATH# 37 Definition	Address: 0694H 0695H
	Operational Interface :	Panel / Software	Communication
	Default :	0x00000000	
	Control Mode :	PR	
	Unit :	-	
	Range :	0x00000000 ~ 0xFFFFFFFF	
	Data Size :	32-bit	
	Format :	Hexadecimal	

Related Section:
7.10

Settings : Please refer to the description of P6-02.

P6-75	PDAT37	PATH# 37 Data	Address: 0696H 0697H
	Operational Interface :	Panel / Software	Communication
	Default :	0	
	Control Mode :	PR	
	Unit :	-	
	Range :	-2147483648 ~ +2147483647	
	Data Size :	32-bit	
	Format :	Decimal	

Related Section:
7.10

Settings : Please refer to the description of P6-03.

P6-76	PDEF38	PATH# 38 Definition		Address: 0698H 0699H
	Operational Interface :	Panel / Software	Communication	Related Section: 7.10
	Default :	0x00000000		
	Control Mode :	PR		
	Unit :	-		
	Range :	0x00000000 ~ 0xFFFFFFFF		
	Data Size :	32-bit		
	Format :	Hexadecimal		

Settings : Please refer to the description of P6-02.

P6-77	PDAT38	PATH# 38 Data		Address: 069AH 069BH
	Operational Interface :	Panel / Software	Communication	Related Section: 7.10
	Default :	0		
	Control Mode :	PR		
	Unit :	-		
	Range :	-2147483648 ~ +2147483647		
	Data Size :	32-bit		
	Format :	Decimal		

Settings : Please refer to the description of P6-03.

P6-78	PDEF39	PATH# 39 Definition		Address: 069CH 069DH
	Operational Interface :	Panel / Software	Communication	Related Section: 7.10
	Default :	0x00000000		
	Control Mode :	PR		
	Unit :	-		

Range :	0x00000000 ~ 0xFFFFFFFF
Data Size :	32-bit
Format :	Hexadecimal

Settings : Please refer to the description of P6-02.

P6-79	PDAT39	PATH# 39 Data		Address: 069EH 069FH
	Operational Interface :	Panel / Software	Communication	Related Section: 7.10
	Default :	0		
	Control Mode :	PR		
	Unit :	-		
	Range :	-2147483648 ~ +2147483647		
	Data Size :	32-bit		
	Format :	Decimal		

Settings : Please refer to the description of P6-03.

P6-80	PDEF40	PATH# 40 Definition		Address: 06A0H 06A1H
	Operational Interface :	Panel / Software	Communication	Related Section: 7.10
	Default :	0x00000000		
	Control Mode :	PR		
	Unit :	-		
	Range :	0x00000000 ~ 0xFFFFFFFF		
	Data Size :	32-bit		
	Format :	Hexadecimal		

Settings : Please refer to the description of P6-02.

P6-81	PDAT40	PATH# 40 Data		Address: 06A2H 06A3H
	Operational Interface :	Panel / Software	Communication	Related Section: 7.10
	Default :	0		
	Control Mode :	PR		
	Unit :	-		
	Range :	-2147483648 ~ +2147483647		
	Data Size :	32-bit		
	Format :	Decimal		

Settings : Please refer to the description of P6-03.

P6-82	PDEF41	PATH# 41 Definition		Address: 06A4H 06A5H
	Operational Interface :	Panel / Software	Communication	Related Section: 7.10
	Default :	0x00000000		
	Control Mode :	PR		
	Unit :	-		
	Range :	0x00000000 ~ 0xFFFFFFFF		
	Data Size :	32-bit		
	Format :	Hexadecimal		

Settings : Please refer to the description of P6-02.

P6-83	PDAT41	PATH# 41 Data		Address: 06A6H 06A7H
	Operational Interface :	Panel / Software	Communication	Related Section: 7.10
	Default :	0		
	Control Mode :	PR		
Unit :	-			

Range :	-2147483648 ~ +2147483647
Data Size :	32-bit
Format :	Decimal

Settings : Please refer to the description of P6-03.

P6-84	PDEF42	PATH# 42 Definition		Address: 06A8H 06A9H
	Operational Interface :	Panel / Software	Communication	Related Section: 7.10
	Default :	0x00000000		
	Control Mode :	PR		
	Unit :	-		
	Range :	0x00000000 ~ 0xFFFFFFFF		
	Data Size :	32-bit		
	Format :	Hexadecimal		

Settings : Please refer to the description of P6-02.

P6-85	PDAT42	PATH# 42 Data		Address: 06AAH 06ABH
	Operational Interface :	Panel / Software	Communication	Related Section: 7.10
	Default :	0		
	Control Mode :	PR		
	Unit :	-		
	Range :	-2147483648 ~ +2147483647		
	Data Size :	32-bit		
	Format :	Decimal		

Settings : Please refer to the description of P6-03.

P6-86	PDEF43	PATH# 43 Definition		Address: 06ACH 06ADH
	Operational Interface :	Panel / Software	Communication	Related Section: 7.10
	Default :	0x00000000		
	Control Mode :	PR		
	Unit :	-		
	Range :	0x00000000 ~ 0xFFFFFFFF		
	Data Size :	32-bit		
	Format :	Hexadecimal		

Settings : Please refer to the description of P6-02.

P6-87	PDAT43	PATH# 43 Data		Address: 06AEH 06AFH
	Operational Interface :	Panel / Software	Communication	Related Section: 7.10
	Default :	0		
	Control Mode :	PR		
	Unit :	-		
	Range :	-2147483648 ~ +2147483647		
	Data Size :	32-bit		
	Format :	Decimal		

Settings : Please refer to the description of P6-03.

P6-88	PDEF44	PATH# 44 Definition		Address: 06B0H 06B1H
	Operational Interface :	Panel / Software	Communication	Related Section: 7.10
	Default :	0x00000000		
	Control Mode :	PR		
Unit :	-			

Range :	0x00000000 ~ 0xFFFFFFFF
Data Size :	32-bit
Format :	Hexadecimal

Settings : Please refer to the description of P6-02.

P6-89	PDAT44	PATH# 44 Data		Address: 06B2H 06B3H
	Operational Interface :	Panel / Software	Communication	Related Section: 7.10
	Default :	0		
	Control Mode :	PR		
	Unit :	-		
	Range :	-2147483648 ~ +2147483647		
	Data Size :	32-bit		
	Format :	Decimal		

Settings : Please refer to the description of P6-03.

P6-90	PDEF45	PATH# 45 Definition		Address: 06B4H 06B5H
	Operational Interface :	Panel / Software	Communication	Related Section: 7.10
	Default :	0x00000000		
	Control Mode :	PR		
	Unit :	-		
	Range :	0x00000000 ~ 0xFFFFFFFF		
	Data Size :	32-bit		
	Format :	Hexadecimal		

Settings : Please refer to the description of P6-02.

P6-91	PDAT45	PATH# 45 Data		Address: 06B6H 06B7H
	Operational Interface :	Panel / Software	Communication	Related Section: 7.10
	Default :	0		
	Control Mode :	PR		
	Unit :	-		
	Range :	-2147483648 ~ +2147483647		
	Data Size :	32-bit		
	Format :	Decimal		

Settings : Please refer to the description of P6-03.

P6-92	PDEF46	PATH# 46 Definition		Address: 06B8H 06B9H
	Operational Interface :	Panel / Software	Communication	Related Section: 7.10
	Default :	0x00000000		
	Control Mode :	PR		
	Unit :	-		
	Range :	0x00000000 ~ 0xFFFFFFFF		
	Data Size :	32-bit		
	Format :	Hexadecimal		

Settings : Please refer to the description of P6-02.

P6-93	PDAT46	PATH# 46 Data		Address: 06BAH 06BBH
	Operational Interface :	Panel / Software	Communication	Related Section: 7.10
	Default :	0		
	Control Mode :	PR		
Unit :	-			

Range :	-2147483648 ~ +2147483647
Data Size :	32-bit
Format :	Decimal

Settings : Please refer to the description of P6-03.

P6-94	PDEF47	PATH# 47 Definition		Address: 06BCH 06BDH
	Operational Interface :	Panel / Software	Communication	Related Section: 7.10
	Default :	0x00000000		
	Control Mode :	PR		
	Unit :	-		
	Range :	0x00000000 ~ 0xFFFFFFFF		
	Data Size :	32-bit		
	Format :	Hexadecimal		

Settings : Please refer to the description of P6-02.

P6-95	PDAT47	PATH# 47 Data		Address: 06BEH 06BFH
	Operational Interface :	Panel / Software	Communication	Related Section: 7.10
	Default :	0		
	Control Mode :	PR		
	Unit :	-		
	Range :	-2147483648 ~ +2147483647		
	Data Size :	32-bit		
	Format :	Decimal		

Settings : Please refer to the description of P6-03.

P6-96	PDEF48	PATH# 48 Definition		Address: 06C0H 06C1H
	Operational Interface :	Panel / Software	Communication	Related Section: 7.10
	Default :	0x00000000		
	Control Mode :	PR		
	Unit :	-		
	Range :	0x00000000 ~ 0xFFFFFFFF		
	Data Size :	32-bit		
	Format :	Hexadecimal		

Settings : Please refer to the description of P6-02.

P6-97	PDAT48	PATH# 48 Data		Address: 06C2H 06C3H
	Operational Interface :	Panel / Software	Communication	Related Section: 7.10
	Default :	0		
	Control Mode :	PR		
	Unit :	-		
	Range :	-2147483648 ~ +2147483647		
	Data Size :	32-bit		
	Format :	Decimal		

Settings : Please refer to the description of P6-03.

P6-98	PDEF49	PATH# 49 Definition		Address: 06C4H 06C5H
	Operational Interface :	Panel / Software	Communication	Related Section: 7.10
	Default :	0x00000000		
	Control Mode :	PR		
	Unit :	-		
	Range :	0x00000000 ~ 0xFFFFFFFF		
	Data Size :	32-bit		
	Format :	Hexadecimal		

Settings : Please refer to the description of P6-02.

P6-99	PDAT49	PATH# 49 Data		Address: 06C6H 06C7H
	Operational Interface :	Panel / Software	Communication	Related Section: 7.10
	Default :	0		
	Control Mode :	PR		
	Unit :	-		
	Range :	-2147483648 ~ +2147483647		
	Data Size :	32-bit		
	Format :	Decimal		

Settings : Please refer to the description of P6-03.

P7-xx PR Parameters (Please refer to Chapter 7 for detailed setting)

P7-00	PDEF50	PATH# 50 Definition		Address: 0700H 0701H
	Operational Interface :	Panel / Software	Communication	Related Section: 7.10
Default :	0x00000000			
Control Mode :	PR			
Unit :	-			
Range :	0x00000000 ~ 0xFFFFFFFF			
Data Size :	32-bit			
Format :	Hexadecimal			

Settings : Please refer to the description of P6-02.

Note: PATH (procedure)

P7-01	PDAT50	PATH# 50 Data		Address: 0702H 0703H
	Operational Interface :	Panel / Software	Communication	Related Section: 7.10
Default :	0			
Control Mode :	PR			
Unit :	-			
Range :	-2147483648 ~ +2147483647			
Data Size :	32-bit			
Format :	Decimal			

Settings : Please refer to the description of P6-03.

P7-02	PDEF51	PATH# 51 Definition		Address: 0704H 0705H
	Operational Interface :	Panel / Software	Communication	Related Section: 7.10
	Default :	0x00000000		
	Control Mode :	PR		
	Unit :	-		
	Range :	0x00000000 ~ 0xFFFFFFFF		
	Data Size :	32-bit		
	Format :	Hexadecimal		

Settings : Please refer to the description of P6-02.

P7-03	PDAT51	PATH# 51 Data		Address: 0706H 0707H
	Operational Interface :	Panel / Software	Communication	Related Section: 7.10
	Default :	0		
	Control Mode :	PR		
	Unit :	-		
	Range :	-2147483648 ~ +2147483647		
	Data Size :	32-bit		
	Format :	Decimal		

Settings : Please refer to the description of P6-03.

P7-04	PDEF52	PATH# 52 Definition		Address: 0708H 0709H
	Operational Interface :	Panel / Software	Communication	Related Section: 7.10
	Default :	0x00000000		
	Control Mode :	PR		
Unit :	-			

Range :	0x00000000 ~ 0xFFFFFFFF
Data Size :	32-bit
Format :	HEXADECIMAL

Settings : Please refer to the description of P6-02.

P7-05	PDAT52	PATH# 52 Data	Address: 070AH 070BH
Operational Interface :	Panel / Software	Communication	Related Section: 7.10
Default :	0		
Control Mode :	PR		
Unit :	-		
Range :	-2147483648 ~ +2147483647		
Data Size :	32-bit		
Format :	Decimal		

Settings : Please refer to the description of P6-03.

P7-06	PDEF53	PATH# 53 Definition	Address: 070CH 070DH
Operational Interface :	Panel / Software	Communication	Related Section: 7.10
Default :	0x00000000		
Control Mode :	PR		
Unit :	-		
Range :	0x00000000 ~ 0xFFFFFFFF		
Data Size :	32-bit		
Format :	Hexadecimal		

Settings : Please refer to the description of P6-02.

P7-07	PDAT53	PATH# 53 Data		Address: 070EH 070FH
	Operational Interface :	Panel / Software	Communication	Related Section: 7.10
	Default :	0		
	Control Mode :	PR		
	Unit :	-		
	Range :	-2147483648 ~ +2147483647		
	Data Size :	32-bit		
	Format :	Decimal		

Settings : Please refer to the description of P6-03.

P7-08	PDEF54	PATH# 54 Definition		Address: 0710H 0711H
	Operational Interface :	Panel / Software	Communication	Related Section: 7.10
	Default :	0x00000000		
	Control Mode :	PR		
	Unit :	-		
	Range :	0x00000000 ~ 0xFFFFFFFF		
	Data Size :	32-bit		
	Format :	Hexadecimal		

Settings : Please refer to the description of P6-02.

P7-09	PDAT54	PATH# 54 Data		Address: 0712H 0713H
	Operational Interface :	Panel / Software	Communication	Related Section: 7.10
	Default :	0		
	Control Mode :	PR		
	Unit :	-		

Range :	-2147483648 ~ +2147483647
Data Size :	32-bit
Format :	Decimal

Settings : Please refer to the description of P6-03.

P7-10	PDEF55	PATH# 55 Definition	Address: 0714H 0715H
Operational Interface :	Panel / Software	Communication	Related Section: 7.10
Default :	0x00000000		
Control Mode :	PR		
Unit :	-		
Range :	0x00000000 ~ 0xFFFFFFFF		
Data Size :	32-bit		
Format :	Hexadecimal		

Settings : Please refer to the description of P6-02.

P7-11	PDAT55	PATH# 55 Data	Address: 0716H 0717H
Operational Interface :	Panel / Software	Communication	Related Section: 7.10
Default :	0		
Control Mode :	PR		
Unit :	-		
Range :	-2147483648 ~ +2147483647		
Data Size :	32-bit		
Format :	Decimal		

Settings : Please refer to the description of P6-03.

P7-12	PDEF56	PATH# 56 Definition		Address: 0718H 0719H
	Operational Interface :	Panel / Software	Communication	Related Section: 7.10
	Default :	0x00000000		
	Control Mode :	PR		
	Unit :	-		
	Range :	0x00000000 ~ 0xFFFFFFFF		
	Data Size :	32-bit		
	Format :	Hexadecimal		

Settings : Please refer to the description of P6-02.

P7-13	PDAT56	PATH# 56 Data		Address: 071AH 071BH
	Operational Interface :	Panel / Software	Communication	Related Section: 7.10
	Default :	0		
	Control Mode :	PR		
	Unit :	-		
	Range :	-2147483648 ~ +2147483647		
	Data Size :	32-bit		
	Format :	Decimal		

Settings : Please refer to the description of P6-03.

P7-14	PDEF57	PATH# 57 Definition		Address: 071CH 071DH
	Operational Interface :	Panel / Software	Communication	Related Section: 7.10
	Default :	0x00000000		
	Control Mode :	PR		
	Unit :	-		

Range :	0x00000000 ~ 0xFFFFFFFF
Data Size :	32-bit
Format :	Hexadecimal

Settings : Please refer to the description of P6-02.

P7-15	PDAT57	PATH# 57 Data		Address: 071EH 071FH
	Operational Interface :	Panel / Software	Communication	Related Section: 7.10
	Default :	0		
	Control Mode :	PR		
	Unit :	-		
	Range :	-2147483648 ~ +2147483647		
	Data Size :	32-bit		
	Format :	Decimal		

Settings : Please refer to the description of P6-03.

P7-16	PDEF58	PATH# 58 Definition		Address: 0720H 0721H
	Operational Interface :	Panel / Software	Communication	Related Section: 7.10
	Default :	0x00000000		
	Control Mode :	PR		
	Unit :	-		
	Range :	0x00000000 ~ 0xFFFFFFFF		
	Data Size :	32-bit		
	Format :	Hexadecimal		

Settings : Please refer to the description of P6-02.

P7-17	PDAT58	PATH# 58 Data		Address: 0722H 0723H
	Operational Interface :	Panel / Software	Communication	Related Section: 7.10
	Default :	0		
	Control Mode :	PR		
	Unit :	-		
	Range :	-2147483648 ~ +2147483647		
	Data Size :	32-bit		
	Format :	Decimal		

Settings : Please refer to the description of P6-03.

P7-18	PDEF59	PATH# 59 Definition		Address: 0724H 0725H
	Operational Interface :	Panel / Software	Communication	Related Section: 7.10
	Default :	0x00000000		
	Control Mode :	PR		
	Unit :	-		
	Range :	0x00000000 ~ 0xFFFFFFFF		
	Data Size :	32-bit		
	Format :	Hexadecimal		

Settings : Please refer to the description of P6-02.

P7-19	PDAT59	PATH# 59 Data		Address: 0726H 0727H
	Operational Interface :	Panel / Software	Communication	Related Section: 7.10
	Default :	0		
	Control Mode :	PR		
	Unit :	-		

Range :	-2147483648 ~ +2147483647
Data Size :	32-bit
Format :	Decimal

Settings : Please refer to the description of P6-03.

P7-20	PDEF60	PATH# 60 Definition	Address: 0728H 0729H
	Operational Interface :	Panel / Software	Communication
	Default :	0x00000000	
	Control Mode :	PR	
	Unit :	-	
	Range :	0x00000000 ~ 0xFFFFFFFF	
	Data Size :	32-bit	
	Format :	Hexadecimal	

Related Section:
7.10

Settings : Please refer to the description of P6-02.

P7-21	PDAT60	PATH# 60 Data	Address: 072AH 072BH
	Operational Interface :	Panel / Software	Communication
	Default :	0	
	Control Mode :	PR	
	Unit :	-	
	Range :	-2147483648 ~ +2147483647	
	Data Size :	32-bit	
	Format :	Decimal	

Related Section:
7.10

Settings : Please refer to the description of P6-03.

P7-22	PDEF61	PATH# 61 Definition		Address: 072CH 072DH
	Operational Interface :	Panel / Software	Communication	Related Section: 7.10
	Default :	0x00000000		
	Control Mode :	PR		
	Unit :	-		
	Range :	0x00000000 ~ 0xFFFFFFFF		
	Data Size :	32-bit		
	Format :	Hexadecimal		

Settings : Please refer to the description of P6-02.

P7-23	PDAT61	PATH# 61 Data		Address: 072EH 072FH
	Operational Interface :	Panel / Software	Communication	Related Section: 7.10
	Default :	0		
	Control Mode :	PR		
	Unit :	-		
	Range :	-2147483648 ~ +2147483647		
	Data Size :	32-bit		
	Format :	Decimal		

Settings : Please refer to the description of P6-03.

P7-24	PDEF62	PATH# 62 Definition		Address: 0730H 0731H
	Operational Interface :	Panel / Software	Communication	Related Section: 7.10
	Default :	0x00000000		
	Control Mode :	PR		
Unit :	-			

Range :	0x00000000 ~ 0xFFFFFFFF
Data Size :	32-bit
Format :	Hexadecimal

Settings : Please refer to the description of P6-02.

P7-25	PDAT62	PATH# 62 Data		Address: 0732H 0733H
	Operational Interface :	Panel / Software	Communication	Related Section: 7.10
	Default :	0		
	Control Mode :	PR		
	Unit :	-		
	Range :	-2147483648 ~ +2147483647		
	Data Size :	32-bit		
	Format :	Decimal		

Settings : Please refer to the description of P6-03.

P7-26	PDEF63	PATH# 63 Definition		Address: 0734H 0735H
	Operational Interface :	Panel / Software	Communication	Related Section: 7.10
	Default :	0x00000000		
	Control Mode :	PR		
	Unit :	-		
	Range :	0x00000000 ~ 0xFFFFFFFF		
	Data Size :	32-bit		
	Format :	Hexadecimal		

Settings : Please refer to the description of P6-02.

P7-27	PDAT63	PATH# 63 Data		Address: 0736H 0737H
	Operational Interface :	Panel / Software	Communication	Related Section: 7.10
	Default :	0		
	Control Mode :	PR		
	Unit :	-		
	Range :	-2147483648 ~ +2147483647		
	Data Size :	32-bit		
	Format :	Decimal		

Settings : Please refer to the description of P6-03.

Table 8.1 Function Description of Digital Input (DI)

Setting Value: 0x01			
DI Name	Function Description of Digital Input (DI)	Trigger Method	Control Mode
SON	When this DI is On, servo is activated (Servo On)	Level triggered	ALL

Setting Value: 0x02			
DI Name	Function Description of Digital Input (DI)	Trigger Method	Control Mode
ARST	After the alarm has been cleared, when the DI is ON the drive will show that the alarm has been cleared.	Rising edge triggered	ALL

Setting Value: 0x03			
DI Name	Function Description of Digital Input (DI)	Trigger Method	Control Mode
GAINUP	In speed and position mode, when the DI is ON (P2-27 should be set to 1), the gain switched to the one multiplies the switching rate.	Level triggered	PT, PR, S

Setting Value: 0x04			
DI Name	Function Description of Digital Input (DI)	Trigger Method	Control Mode
CCLR	Clear the pulse counter and the setting of parameter P2-50. 0: clear the position pulse deviation (It is suitable in PT mode). When DI is ON, the accumulative pulse deviation of the drive will be cleared to 0.	Rising edge triggered, Level triggered	PT, PR

Setting Value: 0x05			
DI Name	Function Description of Digital Input (DI)	Trigger Method	Control Mode
ZCLAMP	When the speed is slower than the setting of zero speed (P1-38), if the DI is ON, the motor stops running.	Level triggered	S

Setting Value: 0x06

DI Name	Function Description of Digital Input (DI)	Trigger Method	Control Mode
CMDINV	In speed and torque modes, when the DI is ON, the input command will be in reverse direction. Note: when you use this function in the torque mode, it is only applicable to analog commands.	Level triggered	S, Sz, T

Setting Value: 0x07

DI Name	Function Description of Digital Input (DI)	Trigger Method	Control Mode
Reserved			

Setting Value: 0x08

DI Name	Function Description of Digital Input (DI)	Trigger Method	Control Mode
CTRG	In PR mode, after selecting the PR command (POS0 ~ 5), when the DI is ON, the motor will rotate according to the command issued by the register.	Rising edge triggered	PR

Setting Value: 0x09

DI Name	Function Description of Digital Input (DI)	Trigger Method	Control Mode
TRQLM	In speed and position mode, when the DI is ON, the motor torque will be limited, and the limited torque command will be internal register or analog voltage command.	Level triggered	PT, PR, S

Setting Value: 0x0A

DI Name	Function Description of Digital Input (DI)	Trigger Method	Control Mode
GTRY	When gantry control function is enabled (P1-74 = 2), if it needs to temporarily disable this function, turn on DI.GTRY will do. And the axis that received the command from DI.GTRY no longer calculates the error between two axes.	Rising edge triggered	PT

Setting Value: 0x0C			
DI Name	Function Description of Digital Input (DI)	Trigger Method	Control Mode
VPL	<p>Latch function of analog position command.</p> <p>When this DI is ON, the motor will be held on the current position.</p> <p>During the time of DI ON, the motor will not operate even when there is any change of analog command. When this DI is OFF, the motor will complete the command during the time the DI is triggered.</p> <p>The position when DI is triggered</p> <p>The voltage when DI is triggered</p> <p>When DI is ON, the analog input command change the amount. The motor is still at the moment.</p> <p>When DI is OFF, the motor will operate to the corresponding position input by analog.</p> <p>Note: The above graph is the commands that haven't gone through P1-65 filter.</p>	Level triggered	PT

Setting Value: 0x0D			
DI Name	Function Description of Digital Input (DI)	Trigger Method	Control Mode
VPRS	<p>Clear function of analog position command</p> <p>When this DI is ON, the motor will be held in the current position.</p> <p>Despite the change of analog command during the time of DI ON, the motor will still stay in the current position even when the DI is OFF. However, the position the motor stays will correspond to the new analog command. Thus, the coordinate system of the motor will be redefined.</p>	Level triggered	PT

Setting Value: 0x0D			
DI Name	Function Description of Digital Input (DI)	Trigger Method	Control Mode
	<p>The graph plots Motor position (Turn) on the vertical axis against Analog input command (V) on the horizontal axis. A red dotted line represents the ideal linear relationship. A solid black line shows the actual motor position, which levels off when the DI is triggered. A blue dashed line shows the redefined coordinate when DI is OFF. Annotations include: 'The position when DI is triggered', 'The voltage when DI is triggered', 'When DI is ON, all input command is invalid.', and 'When DI is OFF, the motor stands still, but its coordinate will be redefined.'</p>		

Setting value: 0x0E			
DI Name	Function Description of Digital Input (DI)	Trigger Method	Control Mode
FEC	Clear the error between full-closed loop linear scale and motor encoder.	Rising edge triggered	PT/PR, Full-closed loop

Setting Value: 0x10			
DI Name	Function Description of Digital Input (DI)	Trigger Method	Control Mode
SPDLM	In torque mode, when the DI is ON, the motor speed will be limited, the limited speed command will be internal register or analog voltage command.	Level triggered	T

Setting Value: 0x11, 0x12, 0x13, 0x1A, 0x1B, 0x1C

DI Name	Function Description of Digital Input (DI)								Trigger Method	Control Mode	
POS0 POS1 POS2 POS3 POS4 POS5	PR Command Selection (1 ~ 64)									Level triggered	PR
	Position Command	POS5	POS4	POS3	POS2	POS1	POS0	CTRG	Corresponding Parameter		
	Homing	0	0	0	0	0	0	↑	P6-00 P6-01		
	Procedure1	0	0	0	0	0	1	↑	P6-02 P6-03		
	~										
	Procedure 50	1	1	0	0	1	0	↑	P6-98 P6-99		
	Procedure 51	1	1	0	0	1	1	↑	P7-00 P7-01		
	~										
	Procedure 63	1	1	1	1	1	1	↑	P7-26 P7-27		

Setting Value: 0x1D

DI Name	Function Description of Digital Input (DI)	Trigger Method	Control Mode
ABSE	When DI.ABSE is ON, it is in ABS mode. DI.ABSQ, DI.ABSC, DI.ABSR, DI.ABSD, and DI.ABSC are enabled. When DI.ABSE is ON, the function of DI4, DO2, and DO3 will be disabled. Function of DI4 will be ASDQ, DO2 will be ABSR and DO3 will be ABSD.	Level triggered	ALL

Setting Value: 0x1F

DI Name	Function Description of Digital Input (DI)	Trigger Method	Control Mode
ABSC	When DI.ABSC is ON, multi-turn data stored in absolute encoder will be cleared. When DI.ABSE is ON, this function is enabled.	Rising edge triggered	ALL

Setting Value: When DI.ABSE is ON, DI4 inputs ABSQ signal, function set by P2-13 is disabled.

DI Name	Function Description of Digital Input (DI)	Trigger Method	Control Mode
ABSQ is always inputted by DI4	During I/O transmission, Handshaking signal will be sent to the servo drive by the controller. When DI.ABSQ is OFF, it means the controller issues Request ; DI.ABSQ is ON means the controller has already received ABSD signal. When DI.ABSE is ON, this DI is enabled. Please refer to diagram 12.4 for detailed description.	Rising and Falling edge triggered	ALL

Setting Value: 0x14, 0x15										
DI Name	Function Description of Digital Input (DI)								Trigger Method	Control Mode
SPD0 SPD1	Internal Speed Command Selection (1 ~ 4)									
	Speed Command Number	DI signal of CN1		Command			Content	Range	Level triggered	
		S P D 1	S P D 0							
	S1	0	0	Mode	S	External analog command	Voltage deviation between V-REF and GND	+/- 10V		
					Sz	N/A	Speed command is 0	0		
	S2	0	1	Register Parameter			P1-09	+/-5000 r/min		
	S3	1	0				P1-10	+/-5000 r/min		
S4	1	1	P1-11				+/- 5000 r/min			

Setting Value: 0x16, 0x17										
DI Name	Function Description of Digital Input (DI)								Trigger Method	Control Mode
TCM0 TCM1	Internal Torque Command Selection (1 ~ 4)									
	Torque Command Number	DI signal of CN1		Command			Content	Range	Level triggered	
		TCM1	TCM0							
	T1	0	0	Mode	T	External analog command	Voltage deviation between T-REF and GND	+/- 10V		
					Tz	N/A	Torque command is 0	0		
	T2	0	1	Register Parameter			P1-12	+/- 300%		
	T3	1	0				P1-13	+/- 300%		
T4	1	1	P1-14				+/- 300%			

Setting Value: 0x18			
DI Name	Function Description of Digital Input (DI)	Trigger Method	Control Mode
S-P	In position and speed mode, if the DI is OFF, it is in speed mode. And it is in position mode when the DI is ON. (P selects PT or PR via DI.PT-PR (0x2B).)	Level triggered	Dual Mode

Setting Value: 0x19			
DI Name	Function Description of Digital Input (DI)	Trigger Method	Control Mode
S-T	In speed and torque mode, if the DI is OFF, it is in speed mode. And it is in torque mode when the DI is ON.	Level triggered	Dual Mode

Setting Value: 0x1F			
DI Name	Function Description of Digital Input (DI)	Trigger Method	Control Mode
ABSC	When DI.ABSC is on, the pulse number stored in absolute encoder is cleared to 0 and the PUU value is reset to P6-01. But this DI is only valid when DI.ABSE is on. Please refer to Section 12.3 for the timing diagram.	Rising-edge triggered	ALL

Setting Value: 0x20			
DI Name	Function Description of Digital Input (DI)	Trigger Method	Control Mode
T-P	In position and torque mode, if the DI is OFF, it is in torque mode; if the DI is ON, then it is in position mode.	Level triggered	Dual Mode

Setting Value: 0x21			
DI Name	Function Description of Digital Input (DI)	Trigger Method	Control Mode
EMGS	When this DI is ON, the motor stops urgently.	Level triggered	ALL

Setting Value: 0x22			
DI Name	Function Description of Digital Input (DI)	Trigger Method	Control Mode
NL (CWL)	Reverse inhibit limit (contact b)	Level triggered	ALL

Setting Value: 0x23			
DI Name	Function Description of Digital Input (DI)	Trigger Method	Control Mode
PL (CCWL)	Forward inhibit limit (contact b)	Level triggered	ALL

Setting Value: 0x24			
DI Name	Function Description of Digital Input (DI)	Trigger Method	Control Mode
ORGP	In PR mode, during the process of homing if the DI is ON \leftrightarrow OFF, the servo will regard this position as the homing origin. (Please refer to the setting of parameter P5-04)	Rising / Falling edge triggered	PR

Setting Value: 0x27			
DI Name	Function Description of Digital Input (DI)	Trigger Method	Control Mode
SHOM	In PR mode, when searching the origin is needed, it will activate the function of searching the origin when the DI is ON. (Please refer to the setting of parameter P5-04)	Rising edge triggered	PR

Setting Value: 0x2B			
DI Name	Function Description of Digital Input (DI)	Trigger Method	Control Mode
PT-PR	When selecting PT-PR dual mode or PT-PR-S multiple mode, source can be selected via this DI. If this DI is OFF, it is in PT mode; If the DI is ON, it is in PR mode.	Level triggered	Dual Mode

Setting value: 0x35			
DI Name	Function Description of Digital Input (DI)	Trigger Methods	Control Mode
ALGN	When E-Cam alignment function is enabled (P2.076.bit0 = 1 & P2.076.bit1 = 1), it executes alignment correction when this DI is on.	Rising edge triggered	PR

Setting Value: 0x36			
DI Name	Function Description of Digital Input (DI)	Trigger Method	Control Mode
CAM	E-Cam engaging control (Please refer to the setting of P5-88 U, Z value) A2-L does not support E-cam function.	Rising / Falling edge triggered	PR

Setting Value: 0x37			
DI Name	Function Description of Digital Input (DI)	Trigger Method	Control Mode
JOGU	When this DI is ON, the motor will JOG in forward direction.	Level triggered	ALL

Setting Value: 0x38			
DI Name	Function Description of Digital Input (DI)	Trigger Method	Control Mode
JOGD	When this DI is on, the motor will JOG in reverse direction.	Level triggered	ALL

Setting Value: 0x39			
DI Name	Function Description of Digital Input (DI)	Trigger Method	Control Mode
EV1	Event trigger command #1 (Refer to the setting of P5-98, P5-99)	Rising /Falling edge triggered	PR

Setting Value: 0x3A			
DI Name	Function Description of Digital Input (DI)	Trigger Method	Control Mode
EV2	Event trigger command #2 (Refer to the setting of P5-98, P5-99)	Rising /Falling edge triggered	PR

Setting Value: 0x3B			
DI Name	Function Description of Digital Input (DI)	Trigger Method	Control Mode
EV3	Event trigger command #3 (It is provided after firmware version V1.008 sub04.)	Rising /Falling edge triggered	PR

Setting Value: 0x3C			
DI Name	Function Description of Digital Input (DI)	Trigger Method	Control Mode
EV4	Event trigger command #4 (It is provided after firmware version V1.008 sub04)	Rising /Falling edge triggered	PR

Setting Value: 0x43, 0x44			
DI Name	Function Description of Digital Input (DI)	Trigger Method	Control Mode
GNUM0 GNUM1	<p>Gear Ratio Selection 0 (Numerator) Gear Ratio Selection 1 (Numerator) GNUM0, GNUM1</p>	Level triggered	PT

Setting Value: 0x45			
DI Name	Function Description of Digital Input (DI)	Trigger Method	Control Mode
INHP	In position mode, when this DI is ON, the external pulse input command is not working. (Note: The function has to be set to DI8 so as to ensure the instantaneity of pulse prohibition)	Level triggered	PT

Setting Value: 0x46			
DI Name	Function Description of Digital Input (DI)	Trigger Method	Control Mode
STOP	Motor stops.	Rising edge triggered	PR

Setting Value: 0x47			
DI Name	Function Description of Digital Input (DI)	Trigger Method	Control Mode
PFQS	This DI can be used to stop the emergency stop of deceleration time. The setting of deceleration time is identical to P5-03. When DI.PFQS is on, AL35F will occur. Then, motor starts to decelerate. When the speed reaches 0, AL3CF occurs and servo is off. Please turn on DI.ARST to servo on the drive again.	Rising edge triggered	PT,PR,T,S

- Note:
- 1) 11 ~ 17 Single control modes; 18 ~ 20 Dual control mode.
 - 2) When P2-10 ~ P2-17 is set to 0, DI has no function.

Table 8.2 Function Description of Digital Output (DO)

Setting Value: 0x01			
DO Name	Function Description of Digital Output (DO)	Trigger Method	Control Mode
SRDY	When the controlled and main circuit power is applied to the drive, this DO is ON if no alarm occurs.	Level triggered	ALL

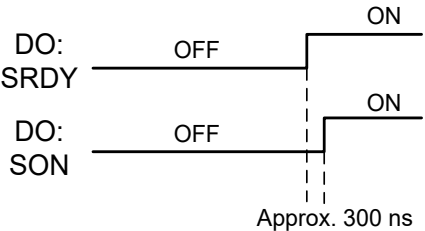
Setting Value: 0x02			
DO Name	Function Description of Digital Output (DO)	Trigger Method	Control Mode
SON	<p>When the servo is ON, this DO is ON if no alarm occurs.</p> <p>As soon as it applies to the power, when it is automatically Servo On, the time difference between DO:SRDY and DO:SON</p> 	Level triggered	ALL

Setting Value: 0x03			
DO Name	Function Description of Digital Output (DO)	Trigger Method	Control Mode
ZSPD	When the motor speed is slower than the setting speed of zero speed (P1-38), this DO is ON.	Level triggered	ALL

Setting Value: 0x04			
DO Name	Function Description of Digital Output (DO)	Trigger Method	Control Mode
TSPD	When the motor speed is faster than the target speed (P1-39), this DO is ON.	Level triggered	ALL

Setting Value: 0x05			
DO Name	Function Description of Digital Output (DO)	Trigger Method	Control Mode
TPOS	<p>In position mode, when the deviation pulse number is smaller than the position range (the setting value of P1-54), this DO is ON.</p> <p>When the drive is in PR mode, this DO is ON when the position error between target position and current position is smaller than the setting value (value of P1-54).</p>	Level triggered	PT, PR

Setting Value: 0x06			
DO Name	Function Description of Digital Output (DO)	Trigger Method	Control Mode
TQL	When it is in torque limit, this DO is ON.	Level triggered	ALL , except T, Tz

Setting Value: 0x07			
DO Name	Function Description of Digital Output (DO)	Trigger Method	Control Mode
ALRM	When the alarm occurs, this DO is ON. (Except DO: 0x11 (forward / reverse limit, communication error, under voltage))	Level triggered	ALL

Setting Value: 0x08			
DO Name	Function Description of Digital Output (DO)	Trigger Method	Control Mode
BRKR	<p>When the signal of brake control is output, adjust the setting of parameter P1-42 and P1-43.</p>	Level triggered	ALL

Setting Value: 0x09			
DO Name	Function Description of Digital Output (DO)	Trigger Method	Control Mode
HOME	<p>When homing is completed, it means the position coordinates system is available and this DO is ON.</p> <p>When applying to the power, this DO is OFF. When homing is completed, this DO is ON. During the operation, this DO is ON until the counter overflows (including command or feedback) and the DO becomes OFF.</p> <p>When PR triggers homing command, this DO becomes OFF. After homing, this DO becomes ON.</p>	Level triggered	PR

Setting Value: 0x0D		
DO Name	Function Description of Digital Output (DO)	Control Mode
ABSW	Warning of absolute encoder.	ALL

Setting Value: 0x0E		
DO Name	Function Description of Digital Output (DO)	Control Mode
IDXD	Indexing coordinates is valid.	PR

Setting Value: 0x10			
DO Name	Function Description of Digital Output (DO)	Trigger Method	Control Mode
OLW	<p>When reaching the overload setting, this DO is ON.</p> <p>t_{OL} = Overload allowable time of the servo x Setting value of P1-56, when the overload accumulative time exceeds t_{OL}, it will output pre-overload warning (OLW). However, if the overload accumulative time exceeds the overload allowable time of the servo, it will output pre-overload error (ALRM).</p> <p>For example: The setting value of pre-overload warning is 60% (P1-56=60). When the output average load of the servo drive is 200%, if the output time exceeds 8 seconds, the servo drive will show the overload alarm (AL006).</p> <p>t_{OL} = The output average load of the servo exceeds 200% for 8 seconds x parameter setting value = 8sec x 60% = 4.8sec Result: When the output average load of the servo drive exceeds 200% for 4.8 seconds, this DO is ON. If it exceeds for 8 seconds, then, DO.ALRM is ON.</p>	Level triggered	ALL

Setting Value: 0x11			
DO Name	Function Description of Digital Output (DO)	Trigger Method	Control Mode
WARN	Warning output (Forward / reverse limit, emergency stop, communication error, under voltage)	Level triggered	ALL

Setting Value: 0x12			
DO Name	Function Description of Digital Output (DO)	Trigger Method	Control Mode
OVF	Position Command /Feedback Overflows	Level triggered	PR

Setting Value: 0x13			
DO Name	Function Description of Digital Output (DO)	Trigger Method	Control Mode
SNL (SCWL)	Software limit (Reverse limit)	Level triggered	PR

Setting Value: 0x14			
DO Name	Function Description of Digital Output (DO)	Trigger Method	Control Mode
SPL (SCCWL)	Software limit (Forward limit)	Level triggered	PR

Setting Value: 0x15			
DO Name	Function Description of Digital Output (DO)	Trigger Method	Control Mode
Cmd_OK	Complete PR command and enter into PR mode, this DO is ON. When PR command is executing, this DO is OFF. After completing the command, this DO is ON. When the DO is ON, it means the command is completed, but not finishing motor positioning. Please refer to DO.TPOS.	Level triggered	PR

Setting Value: 0x16			
DO Name	Function Description of Digital Output (DO)	Trigger Method	Control Mode
CAP_OK	CAP procedure completed	Level triggered	ALL

Setting Value: 0x17			
DO Name	Function Description of Digital Output (DO)	Trigger Method	Control Mode
MC_OK	When DO.Cmd_OK and TPOS are both ON, this DO is ON. Refer to P1-48.	Level triggered	PR

Setting Value: 0x18			
DO Name	Function Description of Digital Output (DO)	Trigger Method	Control Mode
CAM_AREA1	CAM_AREA1: Master position of the E-Cam is between P5-90 and P5-91. A2-L does not support E-Cam function.	Level triggered	PR

Setting Value: 0x19			
DO Name	Function Description of Digital Output (DO)	Trigger Method	Control Mode
SP_OK	Speed completed output: In speed mode, when the deviation between the speed feedback and the command is smaller than the setting value of P1-47, then this DO is ON.	Level triggered	S / Sz

Setting Value: 0x1A			
DO Name	Function Description of Digital Output (DO)	Trigger Method	Control Mode
CAM_AREA2	CAM_AREA2: Master position of the E-Cam is between P2-78 and P2-79. A2-L does not support E-Cam function.	Level triggered	PR

Setting Value: 0x2C		
DO Name	Function Description of Digital Output (DO)	Control Mode
Zon1	When the value which is monitored by P0-09 is between P0-54 ~ P0-55, then this DO is ON.	ALL

Setting Value: When DI.ABSE is ON, DO2 outputs ABSR signal, function set by P2-19 is disabled.			
DO Name	Function Description of Digital Output (DO)	Trigger Method	Control Mode
ABSR is always outputted by DO2	DO.ABSR is OFF means the Request sent by ABSQ has been received. DO.ABSR is ON means the data that is outputted by ABSD is valid. When DI.ABSE is ON, this DO is enabled. Please refer to diagram 12.4 for detailed description.	Level triggered	ALL

Setting Value: When DI.ABSE is ON, DO3 outputs ABSD signal, function set by P2-20 is disabled.			
DO Name	Function Description of Digital Output (DO)	Trigger Method	Control Mode
ABSD is always outputted by DO3	Position data of ABS is outputted. The data is valid when ABSR is ON. When DI.ABSE is ON, this DO is enabled. Please refer to diagram 13.4 for detailed description.	Level triggered	ALL

Setting Value: 0x30			
DO Name	Function Description of Digital Output (DO)	Trigger Method	Control Mode
SDO_0	Output the status of bit 00 of P4-06	Level triggered	ALL

Setting Value: 0x31			
DO Name	Function Description of Digital Output (DO)	Trigger Method	Control Mode
SDO_1	Output the status of bit 01 of P4-06	Level triggered	ALL

Setting Value: 0x32			
DO Name	Function Description of Digital Output (DO)	Trigger Method	Control Mode
SDO_2	Output the status of bit 02 of P4-06	Level triggered	ALL

Setting Value: 0x33			
DO Name	Function Description of Digital Output (DO)	Trigger Method	Control Mode
SDO_3	Output the status of bit 03 of P4-06	Level triggered	ALL

Setting Value: 0x34			
DO Name	Function Description of Digital Output (DO)	Trigger Method	Control Mode
SDO_4	Output the status of bit 04 of P4-06	Level triggered	ALL

Setting Value: 0x35			
DO Name	Function Description of Digital Output (DO)	Trigger Method	Control Mode
SDO_5	Output the status of bit 05 of P4-06	Level triggered	ALL

Setting Value: 0x36			
DO Name	Function Description of Digital Output (DO)	Trigger Method	Control Mode
SDO_6	Output the status of bit 06 of P4-06	Level triggered	ALL

Setting Value: 0x37			
DO Name	Function Description of Digital Output (DO)	Trigger Method	Control Mode
SDO_7	Output the status of bit 07 of P4-06	Level triggered	ALL

Setting Value: 0x38			
DO Name	Function Description of Digital Output (DO)	Trigger Method	Control Mode
SDO_8	Output the status of bit 08 of P4-06	Level triggered	ALL

Setting Value: 0x39			
DO Name	Function Description of Digital Output (DO)	Trigger Method	Control Mode
SDO_9	Output the status of bit 09 of P4-06	Level triggered	ALL

Setting Value: 0x3A			
DO Name	Function Description of Digital Output (DO)	Trigger Method	Control Mode
SDO_A	Output the status of bit 10 of P4-06	Level triggered	ALL

Setting Value: 0x3B			
DO Name	Function Description of Digital Output (DO)	Trigger Method	Control Mode
SDO_B	Output the status of bit 11 of P4-06	Level triggered	ALL

Setting Value: 0x3C			
DO Name	Function Description of Digital Output (DO)	Trigger Method	Control Mode
SDO_C	Output the status of bit 12 of P4-06	Level triggered	ALL

Setting Value: 0x3D			
DO Name	Function Description of Digital Output (DO)	Trigger Method	Control Mode
SDO_D	Output the status of bit 13 of P4-06	Level triggered	ALL

Setting Value: 0x3E			
DO Name	Function Description of Digital Output (DO)	Trigger Method	Control Mode
SDO_E	Output the status of bit 14 of P4-06	Level triggered	ALL

Setting Value: 0x3F			
DO Name	Function Description of Digital Output (DO)	Trigger Method	Control Mode
SDO_F	Output the status of bit 15 of P4-06	Level triggered	ALL

Note: When P2-18 ~ P2-22 is set to 0, DO has no function.

(This page is intentionally left blank,)

Chapter 9 Communications

9.1 RS-485 & RS-232 Communication Hardware Interface

This servo drive supports the serial communication of RS-485 and RS-232. Communication function enables the servo drive to access and change parameters inside the system. However, RS-485 and RS-232 cannot be used at the same time. Parameter P3-05 can use RS-485 or RS-232 as the communication protocol. Followings are the wiring description.

RS-232

■ Configuration

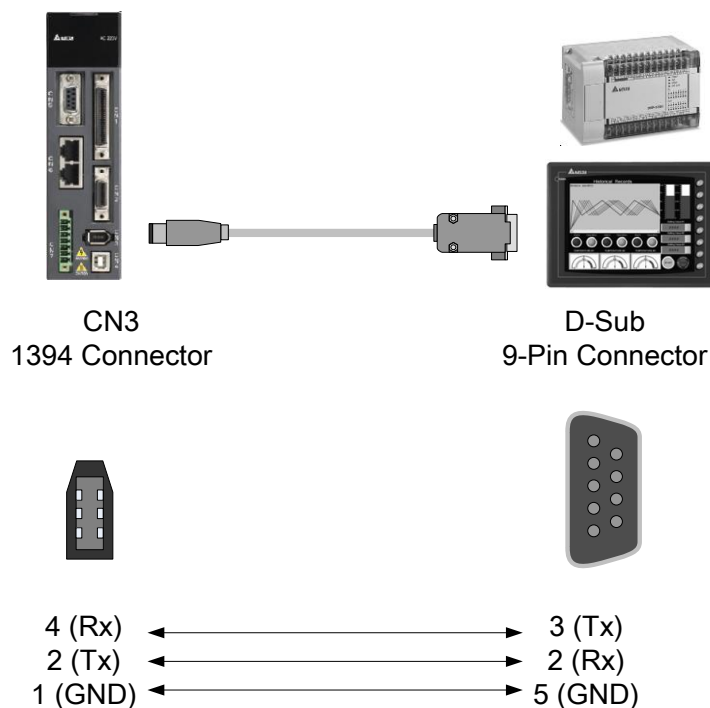

Note:

- 1) The cable length can be up to 15 meters (49.21 feet) when the servo drive is installed in a quiet environment. If the transmission speed is over 38400 bps, however, a cable within 3 meters (9.84 feet) is recommended to ensure data transmission accuracy.
- 2) Numbers shown in the above diagram represent the pin number of each connector.

RS-485

■ Configuration

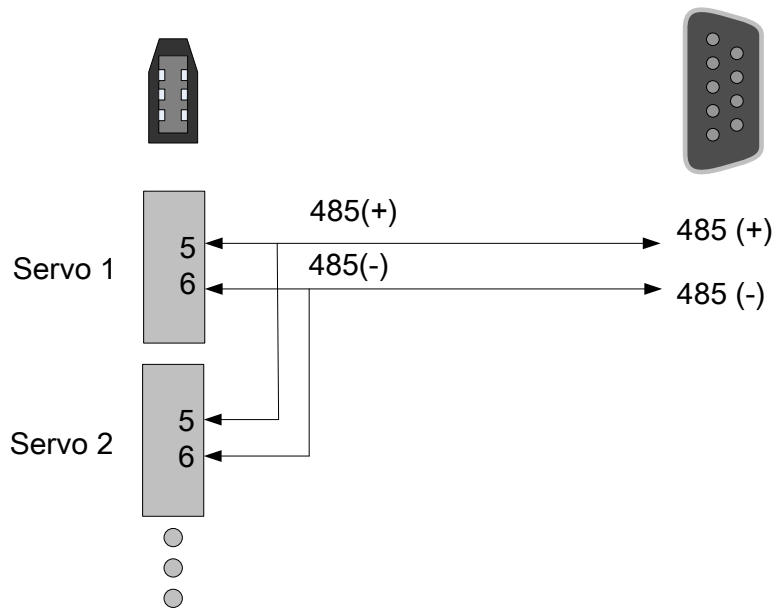
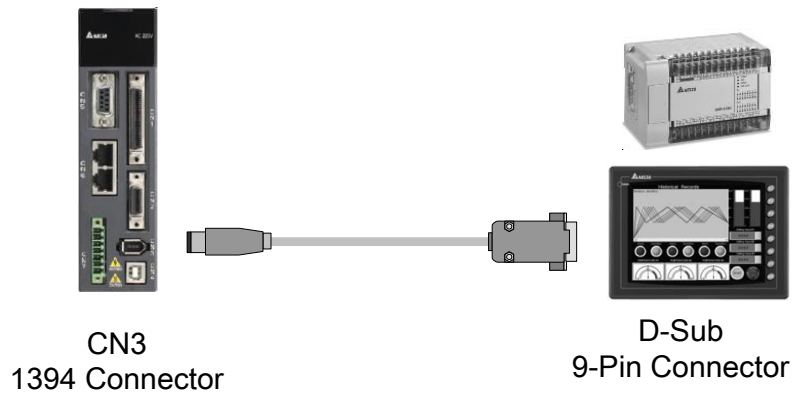

Note:

- 1) The cable length can be up to 100 meters (32.81 feet) when the servo drive is installed in a quiet environment. If the transmission speed is over 38400 bps, however, a cable within 15 meters is recommended to ensure data transmission accuracy.
- 2) Please refer to Section 3.6 for CN3 Pin Definition.

9.2 RS-485 / RS-232 Communication Parameters Setting

The following four parameters, P3-00 (Address Setting), P3-01 (Transmission Speed), P3-02 (Communication Protocol), and P3-05 (Communication Mechanism), are essential and must be set for the communication of the servo drive. The rest, such as P3-03 (Communication Error Disposal), P3-04 (Communication Timeout), P3-06 (Control Switch of Digital Input), and P3-07 (Communication Response Delay Time), are optional. Please refer to Chapter 8 of this user manual.

The followings show the content of parameter P3-00 and its corresponding address, 0300H – 0301H, which is shown in the rightmost column.

P3-00●	ADR	Address Setting		Address: 0300H 0301H
	Operational Interface :	Panel / Software	Communication	Related Section: 9.2
	Default :	0x007F		
	Control Mode :	ALL		
	Unit :	-		
	Range :	0x0001 ~ 0x007F		
	Data Size :	16-bit		
	Format :	Hexadecimal		
	Settings :	The communication address setting is divided into Y, X (hexadecimal):		

	0	0	Y	X
Range	-	-	0 ~ 7	0 ~ F

When using RS-232/RS-485 to communicate, one servo drive can only set one address. The duplicate address setting will cause abnormal communication.

This address represents the absolute address of the servo drive in communication network. It is also applicable to RS-232/485, CANopen, and DMCNET.

When the communication address setting of MODBUS is set to 0xFF, the servo drive will automatically reply and receive data regardless of the address. However, P3-00 cannot be set to 0xFF.

P3-01	BRT	Transmission Speed		Address: 0302H 0303H
	Operational Interface :	Panel / Software	Communication	Related Section: 9.2
	Default :	0x3203 (for DMCNET models) 0x0203 (for other models)		
	Control Mode :	ALL		
	Unit :	bps		
	Range :	0x0000 ~ 0xF405		
	Data Size :	16-bit		
	Format :	Hexadecimal		

Settings : The setting of transmission speed is divided into Z, Y, X (hexadecimal):

	U	Z	Y	X
Communication Port	DMC	CAN / DMC	-	RS-232/485
Range	0 / 3	0 ~ 4	0	0 ~ 5

- Definition of X setting value
 - 0: 4800
 - 1: 9600
 - 2: 19200
 - 3: 38400
 - 4: 57600
 - 5: 115200
- Definition of Z setting value
 - 0: 125 Kbit/s
 - 1: 250 Kbit/s
 - 2: 500 Kbit/s
 - 3: 750 Kbit/s
 - 4: 1.0 Mbit/s
- Definition of U setting value
 - 0: Use Delta's controller, such as PLC and HMI
 - 3: Use Delta's motion card

- Note:
- 1) If this parameter is set via CAN, only Z can be set and the others remain.
 - 2) The communication speed of USB is 1.0 Mbit/s only and is unchangeable.

P3-02	PTL	Communication Protocol	Address: 0304H 0305H
Operational Interface :	Panel / Software	Communication	Related Section: 9.2
Default :	0x0006		
Control Mode :	ALL		
Unit :	-		
Range :	0x0000 ~ 0x0008		
Data Size :	16-bit		
Format :	Hexadecimal		

Settings : The definition of the setting value is as the followings:

- 0: 7, N, 2 (MODBUS, ASCII)
- 1: 7, E, 1 (MODBUS, ASCII)
- 2: 7, O, 1 (MODBUS, ASCII)
- 3: 8, N, 2 (MODBUS, ASCII)
- 4: 8, E, 1 (MODBUS, ASCII)
- 5: 8, O, 1 (MODBUS, ASCII)
- 6: 8, N, 2 (MODBUS, RTU)
- 7: 8, E, 1 (MODBUS, RTU)
- 8: 8, O, 1 (MODBUS, RTU)

P3-05	CMM	Communication Mechanism	Address: 030AH 030BH
Operational Interface :	Panel / Software	Communication	Related Section: 9.2
Default :	0x0000		
Control Mode :	ALL		
Unit :	-		
Range :	0x0000 ~ 0x0001		
Data Size :	16-bit		
Format :	Hexadecimal		

Settings : Communication port can select one or more than one communications.

- Communication Interface
 - 0: RS232 (only applicable to A2-L and A2-M models)
 - 1: RS485 (only applicable to A2-L, A2-M, and A2-LN models)

9.3 MODBUS Communication Protocol

There are two modes of MODBUS networks communication, ASCII (American Standard Code for information interchange) mode and RTU (Remote Terminal Unit) mode. Users could set the needed communication protocol via parameter P3-02. Apart from these two communication modes, this servo drive also supports functions of 03H to access more than one data, 06H to write one character, and 10H to write multiple characters. Please refer to the following descriptions.

■ Code Description

ASCII Mode:

The so-called ASCII mode is using American Standard Code for Information Interchange (ASCII) to transmit the data. If desiring to transmit data 64H between two stations (Master and Slave), the master will send '6' represented by 36H of ASCII code and '4' represented by 34H of ASCII code.

ASCII code of digits 0 to 9 and characters A to F is as follows:

Character	'0'	'1'	'2'	'3'	'4'	'5'	'6'	'7'
ASCII code	30H	31H	32H	33H	34H	35H	36H	37H
Character	'8'	'9'	'A'	'B'	'C'	'D'	'E'	'F'
ASCII code	38H	39H	41H	42H	43H	44H	45H	46H

RTU Mode:

Every 8-bit of data is constituted by two 4-bits hexadecimal characters. If data 64H is transmitted between two stations, it will be transmitted directly, which is more efficient than ASCII mode.

■ Character Structure

Characters will be encoded into the following framing and transmitted in serial. The checking method of different bits is as the following.

10-bit character frame (For 7-bit character)

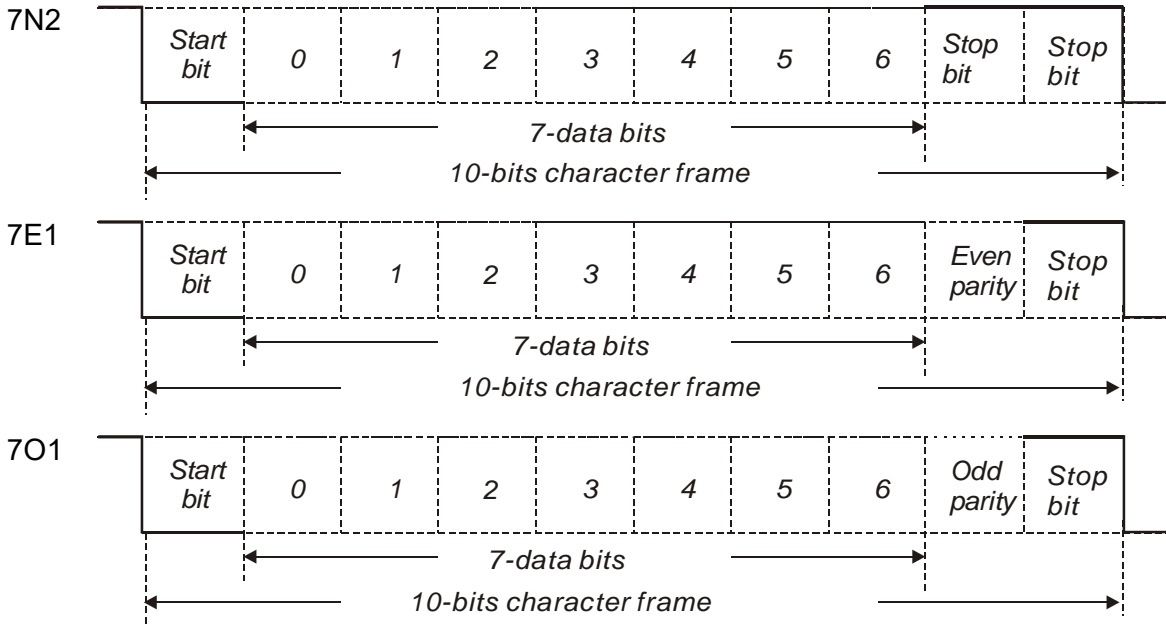

11-bit character frame (For 8-bit character)

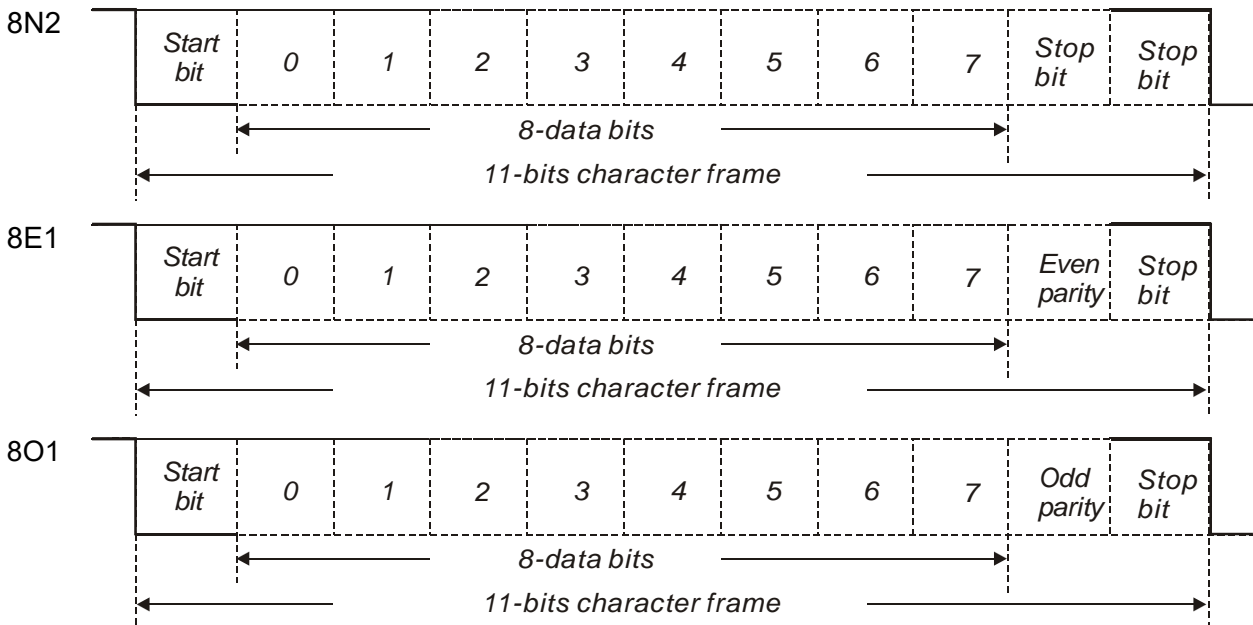

■ Communication Data Structure

Definitions for the data frames in the two modes are as follows:

ASCII Mode:

Start	Start character ': ' (3AH)
Slave Address	Communication address: 1-byte consists of 2 ASCII codes
Function	Function code: 1-byte consists of 2 ASCII codes
Data (n-1)	Data content: n-word = 2n-byte includes 4n of ASCII code, $n \leq 10$
.....	
Data (0)	
LRC	Error checking: 1-byte consists of 2 ASCII codes
End 1	End code 1: (0DH)(CR)
End 0	End code 0: (0AH)(LF)

The start character of communication in ASCII mode is colon ':' (ASCII is 3AH), ADR is the ASCII code of two characters. The end code is CR (Carriage Return) and LF (Line Feed). And the communication address, function code, data content, error checking LRC (Longitudinal Redundancy Check), etc. are between the start character and end code.

RTU Mode:

Start	A silent interval of more than 10 ms
Slave Address	Communication address: 1-byte
Function	Function code: 1-byte
Data (n-1)	Data content : n-word =2n-byte · $n \leq 10$
.....	
Data (0)	
CRC	Error checking: 2-byte
End 1	A silent interval of more than 10 ms

The start of communication in RTU (Remote Terminal Unit) mode is a silent interval. The end of it is another silent interval. The communication address, function code, data content, error checking CRC (Cyclical Redundancy Check), etc. are between the start and the end.

Example 1: function code 03H, access multiple words:

The Master issues the command to the 1st Slave and reads the continuous 2 words starting from the start address 0200H. In response message from the Slave, the content of starting address 0200H is 00B1H and the content of the 2nd data address 0201H is 1F40H. The maximum allowable data in one single access is 10. The calculation of LRC and CRC will be described in the following sections.

ASCII Mode:

Command message (Master):

Start	‘.’
Slave Address	‘0’
	‘1’
Function	‘0’
	‘3’
Starting data address	‘0’
	‘2’
	‘0’
	‘0’
Number of data (In Word)	‘0’
	‘0’
	‘0’
	‘2’
LRC Check	‘F’
	‘8’
End 1	(0DH)(CR)
End 0	(0AH)(LF)

Response message (Slave):

Start	‘.’
Slave Address	‘0’
	‘1’
Function	‘0’
	‘3’
Number of data (In Byte)	‘0’
	‘4’
Content of starting data address 0200H	‘0’
	‘0’
	‘B’
Content of second data address 0201H	‘1’
	‘F’
	‘4’
LRC Check	‘0’
	‘E’
End 1	(0DH)(CR)
End 0	(0AH)(LF)

RTU Mode:**Command message (Master):**

Slave Address	01H
Function	03H
Starting data address	02H (High)
	00H (Low)
Number of data (In Word)	00H
	02H
CRC Check Low	C5H (Low)
CRC Check High	B3H (High)

Response message (Slave):

Slave Address	01H
Function	03H
Number of data (In Byte)	04H
Content of starting data address 0200H	00H (High)
	B1H (Low)
Content of second data address 0201H	1FH (High)
	40H (Low)
CRC Check Low	A3H (Low)
CRC Check High	D4H (High)

Note:

Before and after the transmission in RTU mode, 10 ms of silent interval is needed.

Example 2: function code 06H, write single word:

The Master issues command to the 1st Slave and writes data 0064H to address 0200H. The Slave sends the response message to the Master after the writing is completed. The calculation of LRC and CRC will be described in the following sections.

ASCII Mode:

Command message (Master):

Start	‘:’
Slave Address	‘0’
	‘1’
Function	‘0’
	‘6’
Starting data address	‘0’
	‘2’
	‘0’
	‘0’
Data content	‘0’
	‘0’
	‘6’
	‘4’
LRC Check	‘9’
	‘3’
End 1	(0DH)(CR)
End 0	(0AH)(LF)

Response message (Slave):

Start	‘:’
Slave Address	‘0’
	‘1’
Function	‘0’
	‘6’
Starting data address	‘0’
	‘2’
	‘0’
	‘0’
Data content	‘0’
	‘0’
	‘6’
	‘4’
LRC Check	‘9’
	‘3’
End 1	(0DH)(CR)
End 0	(0AH)(LF)

RTU Mode:

Command message (Master):

Address	01H
Slave Function	06H
Starting data address	02H (High)
	00H (Low)
Data content	00H (High)
	64H (Low)
CRC Check Low	89H (Low)
CRC Check High	99H (High)

Response message (Slave):

Address	01H
Slave Function	06H
Starting data address	02H (High)
	00H (Low)
Data content	00H (High)
	64H (Low)
CRC Check Low	89H (Low)
CRC Check High	99H (High)

Note:

Before and after the transmission in RTU mode, 10 ms of silent interval is needed.

Example 3: function code 10H, write multiple words:

The Master issues command to the 1st Slave and writes 0BB8H and 0000H to the starting address 0112H. That is to say, 0112H is written into 0BB8H and 0113H is written into 0000H. The maximum allowable data in one single access is 10. The Slave sends the response message to the Master after the writing is completed. The calculation of LRC and CRC will be described in the following sections.

ASCII Mode:

Command message (Master):

Start	‘.’
Slave Address	‘0’
	‘1’
Function	‘1’
	‘0’
Starting data address	‘0’
	‘1’
	‘1’
	‘2’
Number of data (In Word)	‘0’
	‘0’
	‘0’
	‘2’
Number of data (In Byte)	‘0’
	‘4’
The first data content	‘0’
	‘B’
	‘B’
The second data content	‘8’
	‘0’
	‘0’
	‘0’
LRC Check	‘0’
	‘3’
End 1	(0DH)(CR)
End 0	(0AH)(LF)

Response message (Slave):

Start	‘.’
Slave Address	‘0’
	‘1’
Function	‘1’
	‘0’
Starting data address	‘0’
	‘1’
	‘1’
	‘2’
Number of data	‘0’
	‘0’
	‘0’
	‘2’
LRC Check	‘D’
	‘A’
End 1	(0DH)(CR)
End 0	(0AH)(LF)

RTU Mode:**Command message (Master):**

Slave Address	01H
Function	10H
Starting data address	01H (High)
	12H (Low)
Number of data (In Word)	00H (High)
	02H (Low)
Number of data (In Byte)	04H
The first data content	0BH (High)
	B8H (Low)
The second data content	00H (High)
	00H (Low)
CRC Check Low	FCH (Low)
CRC Check High	EBH (High)

Response message (Slave):

Slave Address	01H
Function	10H
Starting data address	01H (High)
	12H (Low)
Number of data (In Word)	00H (High)
	02H (Low)
CRC Check Low	E0H (Low)
CRC Check High	31H (High)

Note:

Before and after the transmission in RTU mode, 10 ms of silent interval is needed.

■ LRC and CRC transmission Error Checking

The error checking in ASCII communication mode is LRC (Longitudinal Redundancy Check); CRC (Cyclical Redundancy Check) is for RTU communication mode. The algorithm of both is as the following.

LRC (ASCII mode):

Start	‘.’
Slave address	‘7’
	‘F’
Function	‘0’
	‘3’
Starting data address	‘0’
	‘5’
	‘C’
	‘4’
Number of data	‘0’
	‘0’
	‘0’
	‘1’
LRC Check	‘B’
	‘4’
End 1	(0DH)(CR)
End 0	(0AH)(LF)

The LRC algorithm is: add all bytes, round down the carry, and take 2’s complement. For example, 7FH + 03H + 05H + C4H + 00H + 01H = 14CH, round down the carry 1 and take 4CH.

2’s complement of 4CH is B4H.

CRC (RTU Mode):

The description of CRC is as the followings:

- Step 1: Load a 16-bits register of FFFFH, which is called **CRC** register.
- Step 2: (The low byte of CRC register) XOR (The first byte of command), and save the result in CRC register.
- Step 3: Right move one bit. Check the least significant bit (LSB) of CRC register. If the bit is 1, then (CRC register) XOR (A001H).
- Step 4: Return to Step 3 until Step 3 has been executed for 8 times. Go to Step 5.
- Step 5: Repeat the procedure from Step 2 to Step 4 until all bytes are processed. Get the result of CRC value.

Description: After calculating CRC value, fill in the low word of CRC first in command message, and then fill in the high word of CRC. For example, if the result of CRC algorithm is 3794H, fill in 94H in low word and then 37H in high word, as shown in the following figure.

ADR	01H
CMD	03H
Starting data address	01H (High)
	01H (Low)
Number of data (In Word)	00H (High)
	02H (Low)
CRC Check Low	94H (Low)
CRC Check High	37H (High)

Example of CRC program:

Produce CRC in C language. This function needs two parameters:

unsigned char* data;

unsigned char length

The function returns the CRC value as a type of unsigned integer.

```

unsigned int crc_chk(unsigned char* data, unsigned char length) {
    int j;
    unsigned int reg_crc=0xFFFF;

    while( length-- ) {
        reg_crc^= *data++;
        for (j=0; j<8; j++ ) {
            if( reg_crc & 0x01 ) { /*LSB(bit 0 ) = 1 */
                reg_crc = (reg_crc >> 1)^0xA001;
            } else {
                reg_crc = (reg_crc>>1);
            }
        }
    }
    return reg_crc;
}

```

PC communication program example:

```

#include<stdio.h>
#include<dos.h>
#include<conio.h>
#include<process.h>
#define PORT 0x03F8      /* the address of COM 1 */
#define THR 0x0000
#define RDR 0x0000
#define BRDL 0x0000
#define IER 0x0001
#define BRDH 0x0001
#define LCR 0x0003
#define MCR 0x0004
#define LSR 0x0005
#define MSR 0x0006
unsigned char rdat[60];
/* read 2 data from address 0200H of ASD with address 1 */
unsigned char tdat[60]={':', '0', '1', '0', '3', '0', '2', '0', '0', '0', '0', '0', '2', 'F', '8', '\r', '\n'};

```

```

void main() {
int I;
outportb(PORT+MCR,0x08);          /* interrupt enable */
outportb(PORT+IER,0x01);          /* interrupt as data in */
outportb(PORT+LCR,( inportb(PORT+LCR) | 0x80 ) );
/* the BRDL/BRDH can be access as LCR.b7 == 1 */
outportb(PORT+BRDL,12);
outportb(PORT+BRDH,0x00);
outportb(PORT+LCR,0x06);          /* set prorocol
                                   <7,E,1> = 1AH,          <7,O,1> = 0AH
                                   <8,N,2> = 07H          <8,E,1> = 1BH
                                   <8,O,1> = 0BH          */

for( I = 0; I<=16; I++ ) {
    while( !(inportb(PORT+LSR) & 0x20) ); /* wait until THR empty */
    outportb(PORT+THR,tdat[I]);          /* send data to THR */
}
I = 0;
while( !kbhit() ) {
    if( inportb(PORT+LSR)&0x01 ) { /* b0==1, read data ready */
        rdat[I++] = inportb(PORT+RDR); /* read data from RDR */
    }
}
}
}

```

9.4 Write-in and Read-out Communication Parameters

Please refer to Chapter 8, Parameters, for all parameter details. And the descriptions of parameters which can be wrote or read through communication are as follows.

Parameters are divided into 8 groups, Group 0: Monitor Parameters, Group 1: Basic Parameters, Group 2: Expansion Parameters, Group 3: Communication Parameters, Group 4: Diagnosis Parameters, Group 5: Motion Setting, Group 6 and Group 7: PR Definition.

Write parameters via communication:

Parameters which can be written through communication include:

Group 0, except (P0-00 ~ P0-01), (P0-08 ~ P0-13), and (P0-46)

Group 1 (P1-00 ~ P1-76)

Group 2 (P2-00 ~ P2-67)

Group 3 (P3-00 ~ P3-11)

Group 4, except (P4-00 ~ P4-04) and (P4-08 ~ P4-09)

Group 5 (P5-00 ~ P5-99), except P5-10, P5-16, and P5-76

Group 6 (P6-00 ~ P6-99)

Group 7 (P7-00 ~ P7-27)

Please note that:

- (P3-01) When changing to a new communication speed, the next data will be written in a new transmission speed after setting the new value.
- (P3-02) When changing to the new communication protocol, the next data will be written with the new communication protocol after setting the new value.
- (P4-05) JOG controls parameters of the servo. Please refer to Chapter 8, Parameters, for the description.
- (P4-06) Force to control output contact. This parameter is for DO (Digital Output) testing. Users can write 1, 2, 4, 8, and 16 to test DO1, DO2, DO3, DO4, and DO5 respectively. Please write 0 after the test so as to inform the servo drive that the test has been completed.
- (P4-10) Adjustment function selection. Write 20 (= 14H in hexadecimal format) in parameter P2-08 first to enable the adjustment so as to change the value of P4-10.
- (P4-11 ~ P4-21) This parameter is Offset Adjustment. Do not change the setting unless it is necessary. If it is necessary, please write 22 (= 16H, in hexadecimal format) in parameter P2-08 first to enable the function so as to change the values of P4-11 ~ P4-21.

Read parameters through communication:

Parameters can be read through communication include:

Group 0 (P0-00 ~ P0-46)

Group 4 (P4-00 ~ P4-23)

Group 1 (P1-00 ~ P1-76)

Group 5 (P5-00 ~ P5-99)

Group 2 (P2-00 ~ P2-67)

Group 6 (P6-00 ~ P6-99)

Group 3 (P3-00 ~ P3-11)

Group 7 (P7-00 ~ P7-27)

(This page is intentionally left blank.)

Chapter 10 Troubleshooting

10.1 Alarm of Servo Drive

Display	Alarm Name	Alarm Description	Corresponding DO	Servo Status
AL001	Over current	The current of the main circuit is 1.5 times more than the instantaneous current of the servo drive.	ALM	Servo Off
AL002	Over voltage	The voltage of the main circuit is higher than the standard voltage.	ALM	Servo Off
AL003	Under voltage	The voltage of the main circuit is lower than the standard voltage.	WARN	Servo Off
AL004	Motor Combination Error	The drive corresponds to the wrong motor.	ALM	Servo Off
AL005	Regeneration Error	Regeneration control is in error.	ALM	Servo Off
AL006	Overload	The motor and the drive are overloaded.	ALM	Servo Off
AL007	Over speed	The control speed of the motor exceeds the normal speed.	ALM	Servo Off
AL008	Abnormal Pulse Command	The input frequency of the pulse command is over the allowable value of the hardware interface.	ALM	Servo Off
AL009	Excessive Deviation of Position Command	The deviation of position command exceeds the allowable setting value.	ALM	Servo Off
AL011	Encoder Error	The encoder produces abnormal pulses.	ALM	Servo Off
AL012	Adjustment Error	When executing electrical adjustment, the adjusted value exceeds the allowable value.	ALM	Servo Off
AL013	Emergency Stop	Press the emergency stop button.	WARN	Servo Off
AL014	Reverse Limit Error	Activate the reverse limit switch.	WARN	Servo On
AL015	Forward Limit Error	Activate the forward limit switch.	WARN	Servo On

Display	Alarm Name	Alarm Description	Corresponding DO	Servo Status
AL016	IGBT Overheat	The temperature of IGBT is too high	ALM	Servo Off
AL017	Abnormal EEPROM	An error occurs when the DSP accesses EEPROM.	ALM	Servo Off
AL018	Abnormal signal output	The encoder output exceeds the rated output frequency.	ALM	Servo Off
AL019	Serial Communication Error	RS-232/485 communication is in error	ALM	Servo Off
AL020	Serial Communication Time Out	RS-232/485 communication time out	WARN	Servo On
AL022	Main Circuit Power Lack Phase	RST power cable is loose or there is no power.	WARN	Servo Off
AL023	Early Warning for Overload	Early warning for overload	WARN	Servo On
AL024	Encoder initial magnetic field error	The magnetic field of the encoder U, V, W signal is in error.	ALM	Servo Off
AL025	The Internal of the Encoder is in Error	The internal memory of the encoder and the internal counter are in error.	ALM	Servo Off
AL026	Unreliable internal data of the encoder	The error of the internal data has been detected for three times continuously.	ALM	Servo Off
AL027	The Internal of the Motor is in Error	The encoder reset error	ALM	Servo Off
AL028	Encoder voltage error or the internal of the encoder is in error	Charging circuit of the servo drive is not removed and the battery voltage is higher than the specification (> 3.8 V) or the encoder signal is in error.	ALM	Servo Off
AL029	Gray code error	Absolute position is in error.	ALM	Servo Off
AL030	Motor Crash Error	The motor crashes the equipment, reaches the torque of P1-57 and exceeds the time set by P1-58.	ALM	Servo Off
AL031	Incorrect wiring of the motor power line U, V, W, GND	Incorrect wiring of the motor power line U, V, W, and GND or disconnection.	ALM	Servo Off

Display	Alarm Name	Alarm Description	Corresponding DO	Servo Status
AL034	Internal communication of the encoder is in error	1. Internal communication error of the absolute encoder 2. Internal error of other type of encoder	ALM	Servo Off
AL035	Encoder temperature exceeds the protective range	Encoder temperature exceeds the protective range.	ALM	Servo Off
AL040	Excessive Deviation of Full Closed-loop Position Control	Excessive Deviation of Full Closed-loop Position Control.	ALM	Servo Off
AL041	Communication of linear scale is breakdown.	Linear scale communication is cut off.	ALM	Servo Off
AL042	Analog input voltage error	The analog voltage is over than the setting value of P1-83.	ALM	Servo Off
AL044	Warning of servo drive function overload	When the servo drive function overloads, it might bring the abnormality of motion control, such as PR or E-Cam.	WARN	Servo On
AL045	Wrong setting of E-gear ratio	The setting of E-gear ratio exceeds the range (1/50~25600). Thus, when cycling power on the servo drive, an alarm occurs.	ALM	Servo off
AL060	The absolute position is lost	Due to battery undervoltage or the failure of power supply, the encoder lost the internal record.	WARN	Servo On
AL061	Encoder under voltage	The voltage of the absolute encoder is lower than the specification.	WARN	Servo On
AL062	The multi-turn of absolute encoder overflows	The multi-turn of absolute encoder exceeds the maximum range: -32768 ~ +32767.	WARN	Servo On
AL067	Encoder temperature warning	Encoder temperature exceeds the warning level. (But it is still within the protective range.)	WARN	N/A
AL068	Absolute data transmitted via I/O is in error	The sequence is wrong when reading the absolute position via DIO.	WARN	Servo On
AL069	Wrong motor type	Incremental motor is not allowed to activate the absolute function.	ALM	Servo Off

Display	Alarm Name	Alarm Description	Corresponding DO	Servo Status
AL06A	The absolute coordinate has not been initialized	The absolute origin coordinate has not been created. The possible causes might be: 1. The motor is used for the first time. 2. The battery had run dry but has replaced a new one causing the loss of absolute position.	WARN	Servo On
AL070	Encoder does not complete the command which is issued by servo drive	Command is not completed when the barcode is written to the encoder.	WARN	Servo Off
AL072	Encoder overspeed	When the encoder is powered by the servo drive: the speed is over 8,800 rpm or the acceleration is over 1×10^5 rad/s ² ; when the encoder is powered by the battery: the speed is over 10,000 rpm or the acceleration is over 4×10^3 rad/s ² .	ALM	Servo Off
AL073	Encoder memory error	An error occurs when the encoder is reading data from or writing data to EEPROM.	ALM	Servo Off
AL074	Absolute encoder single turn position error	Absolute encoder single turn position error.	ALM	Servo Off
AL075	Absolute encoder position error	Absolute encoder position error.	ALM	Servo Off
AL077	Encoder computing error	Encoder internal error (internal computing error).	ALM	Servo Off
AL079	Encoder parameter error	The encoder is not cycled after the parameter is written, so the parameter value is not updated.	ALM	Servo Off
AL07A	Loss of encoder Z pulse	Loss of the encoder Z pulse position.	ALM	Servo Off
AL07B	Encoder memory busy	Encoder memory is busy.	ALM	Servo Off
AL07C	Command to clear the absolute position is issued when the motor speed is over 200 rpm	The command to clear the absolute position is issued when the motor speed is over 200 rpm.	WARN	Servo On
AL07D	Servo drive power is cycled before AL07C is cleared	AL07C occurs and is not cleared before the power is cycled on the servo drive, and then the motor stops operating.	ALM	Servo Off

Display	Alarm Name	Alarm Description	Corresponding DO	Servo Status
AL07E	Encoder clearing procedure error	Number of attempts to clear the encoder exceeds the maximum.	ALM	Servo Off
AL083	Servo drive outputs excessive current	When the output current from servo drive exceeds the setting level, AL083 will be triggered to protect IGBT. This could avoid IGBT to be burned out because of the excessive current.	ALM	Servo Off
AL085	Regeneration setting error	Regeneration control error.	ALM	Servo off
AL086	Input voltage is too high	When the servo drive detects no regenerative power, but other regenerative energy (such as interference) is input to the servo drive, or voltage input is higher than the permissible rated voltage.	ALM	Servo Off
AL095	The servo drive does not connect to external regenerative resistor	As for the 220V 5.5 kW model or above, if the value of P1-53 is not 0 and the external regenerative resistor or the brake is not connected, the alarm occurs.	WARN	Servo On
AL099	DSP Firmware Upgrade	EEPROM has not been reset after DSP firmware is upgraded. To clear the alarm, set P2-08 to 30 first and then set it to 28. Next, cycle power on the servo drive.	ALM	Servo Off
AL500	STO function is enabled	Safe torque off function (STO) is enabled.	ALM	Servo Off
AL501	STO_A loss (signal loss or signal error)	Loss of STO_A signal or STO_A and STO_B signals are not synchronized for more than 1 sec.	ALM	Servo Off
AL502	STO_B loss (signal loss or signal error)	Loss of STO_B signal or STO_A and STO_B signals are not synchronized for more than 1 sec.	ALM	Servo Off
AL503	STO self-diagnostic error	STO self-diagnostic error	ALM	Servo Off

10.2 Alarm of CANopen Communication

Display	Alarm Name	Alarm Description	Corrective Actions	Corresponding DO	Servo Status
AL111	CANopen SDO receives buffer overflow	SDO Rx Buffer overflow (receives more than two SDOs within 1 millisecond)	NMT: Reset node or 0x6040.Fault Reset	ALM	Servo On
AL112	CANopen PDO receives buffer overflow	PDO Rx Buffer overflow (receives more than two same PDOs of the COBID within 1 millisecond)	Same as above	ALM	Servo On
AL121	Index error occurs when accessing CANopen PDO	The specified Index in the message does not exist.	Same as above	ALM	Servo On
AL122	Sub-Index error occurs when accessing CANopen PDO	The specified Sub-Index in the message does not exist.	Same as above	ALM	Servo On
AL123	Data Size error occurs when accessing CANopen PDO	The data length in the message does not match to the specified object.	Same as above	ALM	Servo On
AL124	Data range error occurs when accessing CANopen PDO	The data value in the message is over the range of the specified object.	Same as above	ALM	Servo On
AL125	CANopen PDO is read-only and write-protected	The specified object in the message is write-protected.	Same as above	ALM	Servo On
AL126	CANopen PDO is not allowed in PDO	The specified object in the message does not support PDO	Same as above	ALM	Servo On
AL127	CANopen PDO is write-protected when Servo On	The specified object in the message is write-protected when Servo ON.	Same as above	ALM	Servo On
AL128	Error occurs when reading CANopen PDO via EEPROM	An error occurs when loading the default value via ROM at start-up. All objects of CAN returns to the default value automatically.	Same as above	ALM	Servo On

Display	Alarm Name	Alarm Description	Corrective Actions	Corresponding DO	Servo Status
AL129	Error occurs when writing CANopen PDO via EEPROM	An error occurs when saving the current value into ROM.	Same as above	ALM	Servo On
AL130	The accessing address of EEPROM is out of range when using CANopen PDO.	The quantity of the data inside ROM is over the planned space. It is probably because the software has been updated. The data inside ROM is stored by the old version. Thus, it cannot be used.	Same as above	ALM	Servo On
AL131	CRC of EEPROM calculation error occurs when using CANopen PDO	It indicates that the data stored in ROM has been damaged. All objects of CAN will return to the default setting automatically.	Same as above	ALM	Servo On
AL132	Enter the incorrect password when using CANopen PDO	When entering parameters via CAN, the parameters are password-protected. Users have to enter the password to unlock.	Same as above	ALM	Servo On
AL170	Heartbeat or NodeGuarding error	Heartbeat or NodeGuarding error	Same as above	WARN	On
AL180	Heartbeat or NodeGuarding error	Heartbeat or NodeGuarding error	Same as above	ALM	On
AL185	Abnormal CAN Bus hardware	The communication of CAN Bus is breakdown or Error Rx/Tx Counter is over 128.	NMT: Reset node or re-servo on	ALM	Servo On
AL186	CAN Bus off	CAN data transmission error	-	ALM	On

10.3 Alarm of Motion Control

Display	Alarm Name	Alarm Description	Corrective Actions	Corresponding DO	Servo Status
AL201	An error occurs when loading CANopen data	An error occurs when loading data via EEPROM.	DI.ARST, CANopen 0x1011 Restore default parameter	WARN	Servo On
AL207	Parameter group of PR#8 is out of range	The group of PR#8 command source, P_Grp exceeds the range.	DI.ARST, CANopen 0x1011 Restore default parameter	WARN	Servo On
AL209	The parameter number of PR#8 is out of range	Parameter number P_Idx of PR#8 command exceeds the range.	DI.ARST, CANopen 0x1011 Restore default parameter	WARN	Servo On
AL213	The parameter setting of PR#8 is wrong	Write parameters via PR #8: the value is over the range. Please refer to Chapter 7 for detailed description.	DI.ARST, CANopen 0x1011 Restore default parameter	WARN	Servo On
AL215	Write parameters: read-only	Write parameters via PR procedure: the parameter is read-only	DI.Alm Reset or P0-01= 0	WARN	Servo On
AL217	Write parameters: parameter locked	Write parameters via PR procedure: it is write-protected when the servo is ON or the input data is unreasonable.	Correct the PR command and parameter	WARN	Servo On
AL231	The setting of monitor item of PR#8 is out of range	The setting of monitor item of PR#8, Sys_Var exceeds the range.	DI.ARST, CANopen 0x1011 Restore default parameter	WARN	Servo On
AL235	PR command overflows	Feedback position counter overflows and executes the absolute positioning command.	Execute the homing procedure	WARN	Servo On

Display	Alarm Name	Alarm Description	Corrective Actions	Corresponding DO	Servo Status
AL237	Indexing coordinate is undefined	When executing indexing function, if the index positioning command is directly executing before defining the start point of index coordinate, the alarm will therefore occur.	DI.Alm Reset or write 0 into P0-01	WARN	Servo On
AL245	PR positioning timeout	The PR positioning is triggered, and the execution of positioning command is too long.	DI.Alm Reset or write 0 into P0-01; cycle the power	ALM	Servo Off
AL249	The number of PR command exceeds the limit	The number of triggered PR command exceeds the limit.	DI.Alm Reset or write 0 into P0-01; cycle the power	ALM	Servo Off
AL283	Forward Software Limit	The value of position command is bigger than forward software limit (P5-08).	The fault will be cleared automatically when the motor operates backwards.	WARN	Servo On
AL285	Reverse Software Limit	The value of position command is smaller than reverse software limit (P5-09).	The fault will be cleared automatically when the motor operates backwards.	WARN	Servo On
AL289	Feedback position counter overflows	Feedback position counter overflows.	NMT: Reset node or 0x6040.Fault Reset	WARN	Servo On
AL291	Servo OFF error	Servo OFF when the motion path is incomplete.	Same as above	WARN	Servo On
AL301	CANopen fails to synchronize	CANopen IP mode fails to synchronize with the controller.	Same as above	WARN	Servo On
AL302	The synchronized signal of CANopen is sent too fast	The synchronized signal, SYNC of CANopen is sent too fast.	Same as above	WARN	Servo On

Display	Alarm Name	Alarm Description	Corrective Actions	Corresponding DO	Servo Status
AL303	The synchronized signal of CANopen is sent too slow	The synchronized signal, SYNC of CANopen has not been received in time.	Same as above	WARN	Servo On
AL304	CANopen IP command is failed	Command cannot be issued in CANopen IP mode.	Same as above	WARN	Servo On
AL305	SYNC Period is in error	CANopen 301 Obj 0x1006 Data Error.	Same as above	WARN	Servo On
AL35F	Emergency stop (during deceleration)	DI(0x47) is rising-edge triggered. When the speed reaches 0, AL3CF occurs.	Cycle the power	Mode B: WARN Mode C: ALM	Servo On
AL380	Position Deviation Alarm for DO: MC_OK	Please refer to the description of parameter P1-48. After DO.MC_OK is ON, DO.MC_OK becomes OFF because DO.TPOS turns OFF.	DI.Alm Reset or P0-01= 0	WARN	Servo On
AL3CF	Emergency stop	After AL35F has occurred, the speed reaches 0.	Cycle the power	Mode B: WARN Mode C: ALM	Servo Off
AL3F1	Absolute index coordinate undefined	This alarm occurs when you use the communication type servo drives (CANopen, DMCNET, and EtherCAT) with incremental type motors and position overflow occurs, and you send an absolute positioning command without first executing the homing procedure.	Execute homing procedure	ALM	Servo Off
AL400	Index coordinates error	The setting value of P2-52 is set too small and causes index coordinates error.	Adjust the value of P2-52 to the appropriate one	ALM	Off
AL401	NMT Reset command is received when Servo On	NMT Reset command is received when Servo On.	NMT:Reset node or 0x6040.Fault Reset	ALM	Off

AL404	Value of PR special filter setting is too big	The setting value of P1-22 causes inner position error to overflow.	Re-adjust the value of P1-22 until it is appropriate.	ALM	Off
AL555	System Failure	DSP processing error	N/A	N/A	Do not Switch

Note:

If the alarm occurs and is different from the alarm showed in **Alarm of Servo Drive**, **Alarm of CANopen Communication**, and **Alarm of Motion Control**, please contact the distributors or technical personnel.

10.4 Causes and Corrective Actions

Alarm Display

AL001 : Over current

Causes	Checking Method	Corrective Actions
The drive output is short-circuited.	Check if the wiring between the motor and the drive is correct and see if the wire is short-circuited.	Eliminate the short circuit and keep metal conductor from being exposed.
The motor wiring is in error.	Check if the wiring steps are correct when connecting the motor to the drive.	Rewiring by following the wiring description from the user manual.
IGBT is abnormal.	The temperature of the heat sink is abnormal.	Send the drive back to the distributors or contact Delta.
The control parameter setting is in error.	Check if the setting value exceeds the default setting.	Setting back to the default setting and then gradually adjust the value.
Unreasonable command	Check if the command changes greatly.	Less steep command used or filter applying to smooth command.

AL002 : Over voltage

Causes	Checking Method	Corrective Actions
A wrong regenerative resistor is selected or the external regenerative resistor is not connected.	Check the connections for the regenerative resistor.	Re-calculate the value for the regenerative resistor, and reset the values of P1-52 and P1-53. If this does not clear the alarm, please send the servo drive back to Delta.
The input voltage of the main circuit is higher than the rated allowable voltage.	Use the voltmeter to see if the input voltage of the main circuit is within the rated allowable voltage value. (please refer to section 11.1)	Apply to the correct power supply or serial voltage regulator.
Wrong power input (incorrect power system)	Use the voltmeter to see if the power system matches the specification.	Apply to the correct power supply or serial adaptor.
The hardware of the servo drive malfunctions	Use the voltmeter to see if the input voltage of the main circuit is within the rated allowable voltage value but still shows the error.	Send the drive back to the distributors or contact Delta.

AL003 : Under voltage

Causes	Checking Method	Corrective Actions
The input voltage of the main circuit is lower than the rated allowable voltage.	Check if the input voltage wiring of the main circuit is normal.	Re-confirm the voltage wiring.
No power supply for the main circuit.	Use the voltmeter to see if the voltage of the main circuit is normal.	Check the power switch.
Wrong power input (incorrect power system)	Use the voltmeter to see if the power system matches the specification.	Apply to the correct power supply or serial adaptor.

AL004 : Motor Combination Error

Causes	Checking Method	Corrective Actions
The encoder is damaged.	The encoder is abnormal.	Change the motor.
The encoder is loose.	Check the encoder connector.	Install the motor again.
Motor Combination Error	Connect to the right motor.	Change the motor.

AL005 : Regeneration Error

Causes	Checking Method	Corrective Actions
A wrong regenerative resistor is selected or the external regenerative resistor is not connected.	Check the connections for the regenerative resistor.	Re-calculate the value for the regenerative resistor, and reset the values of P1-52 and P1-53. If this does not clear the alarm, please send the servo drive back to Delta.
Parameter P1-53 is not set to zero when the regenerative resistor is not in use.	Check if parameter P1-53 of regenerative resistor is set to zero.	Set parameter P1-53 of regenerative resistor to zero when it is not applying.
Wrong parameter setting	Check the setting values of parameters P1-52 and P1-53.	Correctly reset the setting.

AL006 : Overload

Causes	Checking Method	Corrective Actions
The load is over the rated range and the servo drive is in a persistent overload condition.	Set parameter P0-02 to 11 and see if the average torque [%] is over 100% all the time.	Increase the motor capacity or reduce the load.
The setting of the control system parameter is inappropriate.	1. Check if there is any mechanical vibration. 2. Check if the acceleration / deceleration constant are set too fast.	1. Adjust the gain value of the control circuit. 2. Slow down the acceleration / deceleration setting time.
Wrong wiring of the motor and the encoder.	Check the wiring of U, V, and W and the encoder.	Correct the wiring.
The encoder of the motor is defective.	Send the drive back to the distributors or contact Delta.	

AL007 : Overspeed

Causes	Checking Method	Corrective Actions
A dramatic change in speed	Use the scope to check if the signal of analog voltage is abnormal.	Adjust the signal changing rate or enable the filter function
Inappropriate parameter setting	Check if the setting of parameter P2-34 is too small (the condition of over-speed warning).	Correctly set parameter P2-34 (the condition of over-speed warning).
Torque limit	<ol style="list-style-type: none"> 1. Check if DI.TRQLM (torque limit) is used. 2. Check if the default torque limit of P1-02 is enabled. 3. Check if the torque limit setting in P1-12 ~ P1-14 is enabled. 	<ol style="list-style-type: none"> 1. Disable the torque limit DI. 2. Disable the default setting. 3. P1-12 ~ P1-14 = 100%

AL008 : Abnormal Pulse Command

Causes	Checking Method	Corrective Actions
The pulse command frequency is higher than the rated input frequency.	Use the scope to check if the input frequency is over the rated input frequency.	Correctly set the input pulse frequency.

AL009 : Excessive Deviation of Position Command

Causes	Checking Method	Corrective Actions
The maximum position deviation is set too low	Check the setting value of parameter P2-35 (The warning condition of excessive position deviation).	Increase the setting value of P2-35 (The warning condition of excessive position deviation).
The setting of the gain value is too small.	Check if the setting value is appropriate.	Correctly adjust the gain value.
The torque limit is too low.	Check the torque limit value.	Correctly adjust the torque limit value.
Excessive external load	Check the external load.	Reduce the external load or evaluate the motor capacity again
Improper setting of E-gear ratio	Make sure if the proportion of P1-44 and P1-45 is appropriate.	Correctly setup the E-gear ratio.

AL011 : Encoder Error

Causes	Checking Method	Corrective Actions
Wrong wiring of the encoder	Check if the wiring follows the suggested wiring of the user manual.	Correct the wiring.
The encoder is loose	Check the drive connector of CN2 and encoder	Install the encoder again.
Bad connection of the encoder	Check if the connection between CN2 of the drive and the encoder of the servo motor is loose.	Reconnect the wiring.
The encoder is damaged.	Check if the motor is damaged.	Change the motor.

AL012 : Adjustment Error

Causes	Checking Method	Corrective Actions
The analog input contact is incorrectly set back to zero.	Measure if the voltage of the analog input contact is the same as the ground voltage.	Correctly ground the analog input contact.
The detection device is damaged.	Reset the power supply.	If the error still occurs after reset, send the drive back to the distributors or contact Delta.

AL013 : Emergency Stop

Causes	Checking Method	Corrective Actions
The emergency stop button is pressed.	Check if the emergency stop button is enabled.	Activate emergency stop.

AL014 : Reverse Limit Error

Causes	Checking Method	Corrective Actions
Reverse limit switch is activated.	Check if the limit switch is enabled.	Enable the reverse limit switch.
The servo system is unstable.	Check the control parameter and inertia ratio.	Re-adjust the parameter or evaluate the motor capacity.

AL015 : Forward Limit Error

Causes	Checking Method	Corrective Actions
Forward limit switch is activated.	Check if the limit switch is enabled.	Enable the forward limit switch.
The servo system is unstable.	Check the control parameter and inertia ratio.	Re-adjust the parameter or re-estimate the motor capacity.

AL016 : IGBT Overheat

Causes	Checking Method	Corrective Actions
The load is over the rated range and the servo drive is in a persistent overload condition.	Check if it is overloading or the motor current is too high.	Increase the motor capacity or reduce the load.
The drive output is short-circuited.	Check the drive output wiring.	Correct the wiring.

AL017 : Abnormal EEPROM

Causes	Checking Method	Corrective Actions
It is in error when DSP accesses EEPROM.	Press the SHIFT Key on the panel and it shows EXGAB. X = 1, 2, 3 G = group code of the parameter AB = hexadecimal of the parameter If it shows E320A, it means it is parameter P2-10; if it shows E3610,	The fault occurs when applying to the power. It means one of the parameters is over the reasonable range. Please re-power on after adjusting. The fault occurs in normal operation. It means it is in error

Causes	Checking Method	Corrective Actions
	it means it is parameter P6-16. Please check the parameter.	when writing the parameter. The alarm can be cleared by DI.ARST.
Abnormal hidden parameter	Press the SHIFT Key on the panel and it shows E100X.	The fault occurs in parameter reset. The setting of the drive is wrong. Please set the correct type of the drive.
Data in ROM is damaged.	Press the SHIFT Key on the panel and it shows E0001.	The fault occurs when the servo is on. Usually it is because the data in ROM is damaged or there is no data in ROM. Please send the drive back to the distributors or contact Delta.

AL018 : Abnormal Signal Output

Causes	Checking Method	Corrective Actions
The encoder is in error and thus causes abnormal signal output.	Check the fault records (P4-00 ~ P4-05). See if the encoder error occurs (AL011, AL024, AL025, and AL026).	Conduct the corrective actions of AL011, AL024, AL025, and AL026.
The output pulse exceeds the hardware allowable range.	Check if the following conditions produce: P1-76 < Motor Speed or $\frac{\text{Motor Speed}}{60} \times P1 - 46 \times 4 > 19.8 \times 10^6$	Correctly set parameter P1-76 and P1-46: P1-76 > Motor Speed or $\frac{\text{Motor Speed}}{60} \times P1 - 46 \times 4 < 19.8 \times 10^6$

AL019 : Serial Communication Error

Causes	Checking Method	Corrective Actions
Improper setting of the communication parameter	Check the setting value of communication parameter.	Correctly set the parameter value.
Incorrect communication address	Check the communication address.	Correctly set the communication address.
Incorrect communication value	Check the accessing value.	Correctly set the value.

AL020 : Serial Communication Time Out

Causes	Checking Method	Corrective Actions
Improper setting of the time-out parameter	Check the parameter setting.	Correctly set the value.
The drive hasn't received the communication command for a long time.	Check if the communication cable is loose or broken.	Correct the wiring.

AL022 : Main circuit power leak phase

Causes	Checking Method	Corrective Actions
The main circuit power is abnormal.	Check if RST power cable is loose or there is no power. This alarm occurs when the 1.5 kW (or below) A2 servo drive is not connected to the three-phase power supply. For 2 kW (or above) A2 servo drives, the alarm occurs when one single phase is not connected to the power supply.	Make sure it applies to the power. If the issue persists, please send the drive back to the distributors or contact Delta.

AL023 : Early warning for overload

Causes	Checking Method	Corrective Actions
Early warning for overload	<ol style="list-style-type: none"> 1. Check if it is used in an overload condition. 2. Check if the value of parameter P1-56 is set too small. 	<ol style="list-style-type: none"> 1. Please refer to the corrective actions of AL006. 2. Please increase the setting value of parameter P1-56. Or set the value over 100 and deactivate the overload warning function.

AL024 : Encoder initial magnetic field error

Causes	Checking Method	Corrective Actions
The initial magnetic field of the encoder is in error (Signal, U, V, W of the encoder magnetic field is in error.)	<ol style="list-style-type: none"> 1. Check if the servo motor is properly grounded. 2. Check if the encoder cable separates from the power supply or the high-current circuit to avoid the interference. 3. Check if the shielding cables are used for the encoder. 	If the issue persists, please send the drive back to the distributors or contact Delta.

AL025 : The internal of the encoder is in error

Causes	Checking Method	Corrective Actions
The internal of the encoder is in error. (The internal memory and the internal counter are in error.)	<ol style="list-style-type: none"> 1. Check if the servo is properly grounded. 2. Check if the encoder cable separates from the power supply or the high-current circuit to avoid the interference. 3. Check if the shielding cables are used for the encoder. 	<ol style="list-style-type: none"> 1. Please connect the UVW connector (color green) to the heat sink of the servo drive. 2. Please check if the encoder cable separates from the power supply or the high-current circuit. 3. Please use shielding mesh. 4. If issue persists, please send the drive back to the distributors or contact Delta.
When powered on, the motor operates because of the mechanical inertia or other causes.	When powered on, please make sure the motor shaft stands still and will not operate.	Make sure the motor shaft does not move when power is turned on.

AL026 : Unreliable internal data of the encoder

Causes	Checking Method	Corrective Actions
The encoder is in error. (Errors occur in the internal data for three consecutive times.)	<ol style="list-style-type: none"> 1. Check if the servo is properly grounded. 2. Check if the encoder cable separates from the power supply or the high-current circuit to avoid the interference. 3. Check if the shielding cables are used in the wiring of the encoder. 	<ol style="list-style-type: none"> 1. Please connect the UVW connector (color green) to the heat sink of the servo drive. 2. Please check if the encoder cable separates from the power supply or the high-current circuit. 3. Please use shielding mesh. 4. If the issue persists, please send the drive back to the distributors or contact Delta.

AL027 : The internal of the motor is in error

Causes	Checking Method	Corrective Actions
The internal reset of the encoder is in error.	<ol style="list-style-type: none"> 1. Check if the encoder cable is firmly connected. 2. Check if the power supply for the encoder is stable. 3. Check if the operation temperature is over 95°C (203°F). 	<ol style="list-style-type: none"> 1. Check if the encoder signal cable works normally. 2. Use shielded cable for the encoder signal cable. 3. If the situation is not improving, please send the drive back to the distributors or contact Delta.

AL028 : Encoder voltage error or the internal of the encoder is in error

Causes	Checking Method	Corrective Actions
Battery voltage is too high.	<ol style="list-style-type: none"> 1. Check if the charging circuit exists in the servo drive. 2. Check if the battery is correctly installed. (voltage > 3.8V) 	According to the procedure of Over voltage to check. When corrective actions are done, AL028 will be cleared automatically.
The internal encoder is in error.	<ol style="list-style-type: none"> 1. Check if it is the absolute type encoder. 2. Check if the servo is properly grounded. 3. Check if the encoder cable separates from the power supply or the high-current circuit to avoid the interference. 4. Check if the shielding cables are used in the wiring of the encoder. 	<ol style="list-style-type: none"> 1. If the situation is not improving, please send the drive back to the distributors or contact Delta. 2. Please connect the UVW connector (color green) to the heat sink of the servo drive. 3. Please check if the encoder cable separates from the power supply or the high-current circuit. 4. Please use shielding mesh. If the situation is not improving, please send the drive back to the distributors or contact Delta.

AL029 : Gray code error

Causes	Checking Method	Corrective Actions
Absolute position is in error.	Re-power on to operate the motor and check if the alarm will occur again.	If the alarm occurs again, please change the encoder.

AL030 : Motor Crash Error

Causes	Checking Method	Corrective Actions
Motor Crash Error	<ol style="list-style-type: none"> 1. Check if P1-57 is enabled. 2. Check if P1-57 is set too small and the time of P1-58 is set too short. 	<ol style="list-style-type: none"> 1. If it is enabled by mistake, please set P1-57 to zero. 2. According to the actual torque setting, if the value is set too small, the alarm will be triggered by mistake. However, if the value is set too big, it will lose the function of protection.

AL031 : Incorrect wiring of the motor power line U, V, W

Causes	Checking Method	Corrective Actions
The wiring of U, V, W of the motor is incorrect connected or the connection is breakdown. (Function of connection detection can be enabled or disabled via P2-65 Bit 9. Its default setting is to disable the function.)	Check if U, V, W of the motor is incorrect connected or the connection is breakdown.	Follow the user manual to correctly wire U, V, and W and make sure it is grounded.

AL034 : Internal communication of the encoder is in error

Causes	Checking Method	Corrective Actions
Internal communication of the encoder is in error.	<ol style="list-style-type: none"> 1. Internal communication error of the absolute encoder 2. Internal error of other type of encoder 3. Incorrect wiring of the battery cable. 4. Check the wiring. 5. Check the voltage. 	Conduct the wiring of the battery again and then cycle power on the system.

AL035 : Encoder temperature exceeds the protective range

Causes	Checking Method	Corrective Actions
Encoder temperature exceeds the protective range, above 100°C (212°F).	Check the setting: set the value of P0-02 to 120 to display the temperature.	<ol style="list-style-type: none"> 1. Improve heat dissipation or reduce the loading of operation. The temperature should be lower than 100°C (212°F). 2. If the encoder's temperature is higher than the motor's (more than 30°C (86°F)). Please send the motor back to the distributors.

AL040 : Excessive deviation of full closed-loop position control

Causes	Checking Method	Corrective Actions
Excessive deviation of full closed-loop position control	<ol style="list-style-type: none"> 1. Check if P1-73 is set too small. 2. Check if the connector is loose or there is any connection problem of other mechanism. 	<ol style="list-style-type: none"> 1. Increase the value of P1-73. 2. Check if the connection is well connected.

AL041 : Communication of linear scale is breakdown

Causes	Checking Method	Corrective Actions
The communication of linear scale is breakdown	Check the communication of linear scale.	Check the communication of linear scale again.

AL042 : Analog input voltage error

Causes	Checking Method	Corrective Actions
The analog input voltage is higher than the value of P1-83.	Check if analog input voltage is too high.	<p>Check all analog input voltages.</p> <p>Check if there is any problem about the sources of analog speed commands.</p>

AL044 : Warning of servo drive function overload

Causes	Checking Method	Corrective Actions
Warning of servo drive function overload	N/A	Setting P2-66 Bit4 to 1 can disable the display of this alarm.

AL045 : Wrong setting of E-gear ratio

Causes	Checking Method	Corrective Actions
Setting of E-gear ratio is wrong when power on the servo drive	Check if the setting of E-gear ratio is within the range (1/50~25600).	Modify the range of E-gear ratio and cycle power on the servo drive.

AL060 : The absolute position is lost

Causes	Checking Method	Corrective Actions
Battery under voltage	Check if the voltage of the battery is lower than 2.8V.	After changing the battery, conduct homing procedure again. Please refer to the description of creating the absolute origin coordinate in Chapter 12.
The battery is replaced when the main power of the servo drive is off.	Do not change or remove the battery when the power is OFF, which is controlled by the servo drive.	Conduct homing procedure again. Please refer to the description of creating the absolute coordinate in Chapter 12.
After activating the absolute function, the absolute origin coordinate has not been created.	<ol style="list-style-type: none"> 1. Install the battery. 2. Check the wiring between the battery pack and the power cable of the servo drive. 3. Check the wiring of the encoder. 	Conduct homing procedure. Please refer to the description of creating the absolute origin coordinate in Chapter 12.
Poor connection or disconnection of the battery power circuit	<ol style="list-style-type: none"> 1. Check the wiring of the encoder. 2. Check the wiring between the battery pack and the power cable of the servo drive. 	Connect or repair the wiring of the battery so as to supply the power to the encoder. Conduct homing procedure again. Please refer to the description of creating the absolute origin coordinate in Chapter 12.

AL061 : Encoder under voltage

Causes	Checking Method	Corrective Actions
Battery under voltage	<ol style="list-style-type: none"> 1. Check if the voltage of the battery on the panel is lower than 3.1V (tentative specification). 2. Measure if the voltage of the battery is lower than 3.1V (tentative specification). 	Do not change the battery when the power is ON which is controlled by the servo drive. After you change the battery, AL061 will be cleared automatically.

AL062 : The multi-turn of absolute encoder overflows

Causes	Checking Method	Corrective Actions
Motor's rotation cycle exceeds the allowable range.	Check if the motor's number of turns while operating is within the range between -32768 and +32767.	Conduct homing procedure again. Please refer to the description of creating absolute origin coordinate in Chapter 12.

AL067 : Encoder temperature warning

Causes	Checking Method	Corrective Actions
Encoder temperature exceeds the warning level. (But it is still within the protective range 85°C to 100°C, 185°F to 212°F.)	Check the setting: Set the value of P0-02 to 120 to display the temperature.	<ol style="list-style-type: none"> 1. Improve heat dissipation or reduce the loading of operation. The temperature should be lower than 100°C (212°F). 2. If the encoder's temperature is higher than the motor's (more than 30°C (86°F)). Please send the motor back to the distributors.

AL068 : Absolute data transmitted via I/O is in error

Causes	Checking Method	Corrective Actions
Sequence error	<ol style="list-style-type: none"> 1. Switch OFF DI ABSQ until DO ABSR is OFF. 2. Switch ON ABSQ until DO ABSR is ON. 	Correct the reading sequence of I/O.
Reading time out	Check if the time between switching ON DO ABSR and switching ON ABSQ exceeds 200 ms.	After switching ON DO ABSR (the absolute position data is ready), read DO ABSD and switch ON DI ABSQ within 200 ms so as to inform the servo drive data reading is completed.

AL069 : Wrong motor type

Causes	Checking Method	Corrective Actions
Incremental motor is not allowed to activate the absolute function.	<ol style="list-style-type: none"> 1. Check if the motor is incremental or absolute encoder. 2. Check parameter P2-69. 	If the user desires to use the absolute function, please choose an absolute motor. If not, please set parameter P2-69 to 0.

AL06A : The absolute coordinate has not been initialized

Causes	Checking Method	Corrective Actions
<p>Voltage of the battery is normal, but the encoder loses number of revolutions.</p> <ol style="list-style-type: none"> 1. The motor is used for the first time. 2. The battery had run dry but has replaced a new one. 3. Poor connection or disconnection of the battery power circuit. 	<ol style="list-style-type: none"> 1. Check if the absolute origin coordinate has been created. 2. Check the encoder wiring. 3. Check the connection between the battery box and the servo drive. 	<ol style="list-style-type: none"> 1. Create the absolute origin coordinate. 2. Ensure the battery wiring and execute homing again.

AL070 : Encoder does not complete the command which is issued by servo drive

Causes	Checking Method	Corrective Actions
The servo drive has not completely written barcode into the encoder or the encoder does not complete the command issued by the servo drive.	Check if the encoder wiring is correct or there is any loose connection.	Correctly connect the encoder wiring again.

AL072 : Encoder overspeed

Causes	Checking Method	Corrective Actions
<p>When encoder is powered by the servo drive: the speed is over 8,800 rpm or the acceleration exceeds $1 \times 10^5 \text{ rad/s}^2$.</p> <p>When the encoder is powered by the battery: the speed is over 10,000 rpm or the acceleration is over $4 \times 10^3 \text{ rad/s}^2$.</p>	<ol style="list-style-type: none"> 1. Check if the motor is well grounded. 2. Check if the encoder cable is separated from the power supply or any high-current cable to avoid interference. 3. Check if the encoder uses shielded cable. 4. Check the motor speed. When the application has a high reduction ratio and the connecting mechanism is moved, it results in motor overspeed. 	<ol style="list-style-type: none"> 1. Make sure the UVW connector is grounded to the heat sink of the servo drive. 2. Make sure the encoder signal cable is separated from the power supply or any high-current cable. 3. Use shielded cable for the encoder. 4. Make sure the motor speed is within the rated range. 5. Create the absolute origin coordinate again. 6. If the issue persists, please send your servo drive back to the distributor or contact Delta.

AL073 : Encoder memory error

Causes	Checking Method	Corrective Actions
An error occurs when the encoder is reading data from or writing data to EEPROM.	<ol style="list-style-type: none"> 1. Check if the motor is well grounded. 2. Check if the encoder cable is separated from the power supply or any high-current cable to avoid interference. 3. Check if the encoder uses shielded cable. 4. Check the motor speed. 	<ol style="list-style-type: none"> 1. Make sure the UVW connector is grounded to the heat sink of the servo drive. 2. Make sure the encoder signal cable is separated from the power supply or any high-current cable. 3. Use shielded cable for the encoder. 4. Make sure the motor speed is within the rated range. 5. If the issue persists, please send your servo drive back to the distributor or contact Delta.

AL074 : Absolute encoder single turn position error

Causes	Checking Method	Corrective Actions
Absolute encoder single turn position error	<ol style="list-style-type: none"> 1. Check if the motor is well grounded. 2. Check if the encoder cable is separated from the power supply or any high-current cable to avoid interference. 3. Check if the encoder uses shielded cable. 4. Check the motor speed. 	<ol style="list-style-type: none"> 1. Make sure the UVW connector is grounded to the heat sink of the servo drive. 2. Make sure the encoder signal cable is separated from the power supply or any high-current cable. 3. Use shielded cable for the encoder. 4. Make sure the motor speed is within the rated range. 5. If the issue persists, please send your servo drive back to the distributor or contact Delta.

AL075 : Absolute encoder position error

Causes	Checking Method	Corrective Actions
Absolute encoder position error	<ol style="list-style-type: none"> 1. Check if the motor is well grounded. 2. Check if the encoder cable is separated from the power supply or any high-current cable to avoid interference. 3. Check if the encoder uses shielded cable. 4. Check the motor speed. 	<ol style="list-style-type: none"> 1. Make sure the UVW connector is grounded to the heat sink of the servo drive. 2. Make sure the encoder signal cable is separated from the power supply or any high-current cable. 3. Use shielded cable for the encoder. 4. Make sure the motor speed is within the rated range. 5. If the issue persists, please send your servo drive back to the distributor or contact Delta.

AL077 : Encoder computing error

Causes	Checking Method	Corrective Actions
Encoder internal error (internal computing error)	<ol style="list-style-type: none"> 1. Check if the motor is well grounded. 2. Check if the encoder cable is separated from the power supply or any high-current cable to avoid interference. 3. Check if the encoder uses shielded cable. 4. Check the motor speed. 	<ol style="list-style-type: none"> 1. Make sure the UVW connector is grounded to the heat sink of the servo drive. 2. Make sure the encoder signal cable is separated from the power supply or any high-current cable. 3. Use shielded cable for the encoder. 4. Make sure the motor speed is within the rated range. 5. If the issue persists, please send your servo drive back to the distributor or contact Delta.

AL079 : Encoder parameter error

Causes	Checking Method	Corrective Actions
The encoder is not cycled after the parameter is written, so the parameter value is not updated.	Check if the parameter is written to the encoder.	Cycle power on the servo drive.

AL07A : Loss of encoder Z pulse

Causes	Checking Method	Corrective Actions
Loss of encoder Z pulse position	<ol style="list-style-type: none"> 1. Check if the motor is well grounded. 2. Check if the encoder cable is separated from the power supply or any high-current cable to avoid interference. 3. Check if the encoder uses shielded cable. 	<ol style="list-style-type: none"> 1. Make sure the UVW connector is grounded to the heat sink of the servo drive. 2. Make sure the encoder signal cable is separated from the power supply or any high-current cable. 3. Use shielded cable for the encoder. 4. If the issue persists, please send your servo drive back to the distributor or contact Delta.

AL07B : Encoder memory busy

Causes	Checking Method	Corrective Actions
Encoder memory is busy.	<ol style="list-style-type: none"> 1. Check if the motor is well grounded. 2. Check if the encoder cable is separated from the power supply or any high-current cable to avoid interference. 3. Check if the encoder uses shielded cable. 4. Check the motor speed. 	<ol style="list-style-type: none"> 1. Make sure the UVW connector is grounded to the heat sink of the servo drive. 2. Make sure the encoder signal cable is separated from the power supply or any high-current cable. 3. Use shielded cable for the encoder. 4. Make sure the motor speed is within the rated range. 5. If the issue persists, please send your servo drive back to the distributor or contact Delta.

AL07C : Command to clear the absolute position is issued when the motor speed is over 200 rpm

Causes	Checking Method	Corrective Actions
The command to clear the absolute position is issued when the motor speed is over 200 rpm.	Do not issue a command to clear the absolute position when the motor speed is over 200 rpm.	Follow the procedure for clearing the absolute position to clear this alarm.

AL07D : Servo drive power is cycled before AL07C is cleared

Causes	Checking Method	Corrective Actions
AL07C occurs and is not cleared before the power is cycled on the servo drive, then the motor stops operating.	Check if the encoder parameter is written.	Use DI.ARST to clear the alarm. Once this alarm is cleared, AL07C occurs.

AL07E : Encoder clearing procedure error

Causes	Checking Method	Corrective Actions
The attempts to clear the encoder exceed the limit.	If the issue persists, check the communication quality with the encoder.	Use DI.ARST to clear the alarm.

AL083 : Servo drive outputs excessive current

Causes	Checking Method	Corrective Actions
UVW cable is short-circuited.	Check the configuration of motor power cable and connector cable. See if the metal wire is exposed or AWG is worn and causes short circuit of Uvw cable.	Replace by new UVW cable and avoid the metal conductor being exposed so as to eliminate the short circuit.
Wrong motor wiring	<ol style="list-style-type: none"> If applying non-standard power cable recommended by Delta, please check if the wiring sequence of UVW cable is correct. Check if there is any problem of lack phase when connecting UVW from servo to motor (unconnected or wrong connection). 	Please refer to the description of wiring in Chapter 3 and conduct the wiring again.
Analog signal (GND) from servo drive is interfered.	Check if the GND of analog signal is misconnected to another ground signal.	Please refer to Chapter 3 and conduct the wiring again. GND of analog signal cannot be grounded with other signals.

AL085 : Regeneration error

Causes	Checking Method	Corrective Actions
Choose wrong regenerative resistor or does not connect to external regenerative resistor.	Check the connection of regenerative resistor.	Calculate the value of the regenerative resistor again and correctly set the values of P1-52 and P1-53. If the issue persists, please send the drive back to the distributors or contact Delta.
Parameter P1-53 is not set to zero when the regenerative resistor is not in use.	Check if parameter P1-53 of regenerative resistor is set to zero.	Set parameter P1-53 of regenerative resistor to zero when it is not applying.
Wrong parameter setting	Check the setting value of parameters P1-52 and P1-53.	Correctly reset the values of P1-52 and P1-53.

AL086 : Input voltage is too high

Causes	Checking Method	Corrective Actions
The servo drive detects no regenerative power, but other regenerative energy (such as interference) is input to the servo drive, or voltage input is higher than the permissible rated voltage.	Use a voltmeter to measure if the input voltage from the power source is within the permissible rated value (see the servo drive specifications). If the voltage exceeds the rated value, please remove the interference source.	Use the correct voltage source or connect the voltage regulator in series.
Servo drive (hardware) malfunction	Check if the issue persists when the voltmeter detects that the voltage from the main circuit is within the permissible rated range.	Please send the drive back to distributors or contact Delta.

AL095 : The servo drive does not connect to external regenerative resistor

Causes	Checking Method	Corrective Actions
The input of regenerative resistor capacity is over 0 and the servo drive does not connect to external regenerative resistor	<ol style="list-style-type: none"> 1. Check if it is connected to regenerative resistor. 2. Check if the setting value of P1-53 is 0. 	<ol style="list-style-type: none"> 1. If wishing to apply regenerative brake, please connect to external regenerative resistor. Then, check if the setting of P1-53 is correct. 2. If not applying to regenerative brake, please set P1-53 to 0. 3. If the issue persists after conducting the above two steps, please send the drive back to distributors or contact Delta.

AL099 : DSP firmware upgrade

Causes	Checking Method	Corrective Actions
Upgrade DSP firmware.	Check if the firmware is upgraded.	Firstly set P2-08 to 30. Then set P2-08 to 28, the alarm will be cleared when cycling power on.

AL111 : CANopen SDO receives overflow

Causes	Checking Method	Corrective Actions
SDO Rx Buffer overflow (receives more than two SDOs within 1 ms)	Check if the servo drive receives (sends) more than one SDO within 1 ms.	NMT: Reset node or 0x6040.Fault Reset

AL112 : CANopen PDO receives overflow

Causes	Checking Method	Corrective Actions
PDO Rx Buffer overflow (receives more than two PDOs of COBID within one millisecond)	Check if the servo drive receives (sends) more than one PDO of COBID within 1 ms.	NMT: Reset node or 0x6040.Fault Reset

AL121 : Index error occurs when accessing CANopen PDO

Causes	Checking Method	Corrective Actions
The specified Index in the message does not exist.	Check if the Entry Index of PDO Mapping is modified when PDO is receiving or sending.	NMT: Reset node or 0x6040.Fault Reset

AL122 : Sub-Index error occurs when accessing CANopen PDO

Causes	Checking Method	Corrective Actions
The specified Sub-Index in the message does not exist.	Check if the Entry Sub-index of PDO Mapping is modified when PDO is receiving or sending.	NMT: Reset node or 0x6040.Fault Reset

AL123 : Data Size error occurs when accessing CANopen PDO

Causes	Checking Method	Corrective Actions
The data length in the message does not match to the specified object.	Check if the data length of Entry of PDO Mapping is modified when PDO is receiving or sending.	NMT: Reset node or 0x6040.Fault Reset

AL124 : Data range error occurs when accessing CANopen PDO

Causes	Checking Method	Corrective Actions
The data value in the message is over the range of the specified object.	Check if the written range is wrong when PDO is receiving or sending.	NMT: Reset node or 0x6040.Fault Reset

AL125 : CANopen PDO is read-only and write-protected

Causes	Checking Method	Corrective Actions
The specified object in the message is write-protected.	Check if the specified object is read-only when PDO is receiving or sending.	NMT: Reset node or 0x6040.Fault Reset

AL126 : CANopen PDO is not allowed in PDO

Causes	Checking Method	Corrective Actions
The specified object in the message does not support PDO.	Check if the specified object allows PDO Mapping when PDO is receiving or sending.	NMT: Reset node or 0x6040.Fault Reset

AL127 : CANopen PDO is write-protected when Servo On

Causes	Checking Method	Corrective Actions
The specified object in the message is write-protected when Servo ON.	Check that when PDO is receiving or sending, if the specified object is write-protected when Servo On.	NMT: Reset node or 0x6040.Fault Reset

AL128 : Error occurs when reading CANopen PDO via EEPROM

Causes	Checking Method	Corrective Actions
An error occurs when loading the default value via ROM at start-up. All objects of CAN returns to the default value automatically.	When PDO is receiving or sending, check if the error occurs because the specified object reads EEPROM.	NMT: Reset node or 0x6040.Fault Reset

AL129 : Error occurs when writing CANopen PDO via EEPROM

Causes	Checking Method	Corrective Actions
An error occurs when saving the current value into ROM.	When PDO is receiving or sending, check if the error occurs because the specified object is written into EEPROM.	NMT: Reset node or 0x6040.Fault Reset

AL130 : The accessing address of EEPROM is out of range when using CANopen PDO

Causes	Checking Method	Corrective Actions
The quantity of the data in the ROM is over the allowable space. It is probably because the software has been updated. The data in the ROM is stored by the old version. Thus, it cannot be used.	Check if the addressing in EEPROM exceeds the range for the specified object during PDO receiving or sending.	NMT: Reset node or 0x6040.Fault Reset

AL131 : CRC of EEPROM calculation error occurs when using CANopen PDO

Causes	Checking Method	Corrective Actions
It means the data stored in ROM is damaged. All CANopen objects automatically returns to the default value.	Check if the specified object would cause CRC calculation error in EEPROM when PDO is receiving or sending.	NMT: Reset node or 0x6040.Fault Reset

AL132 : Enter the incorrect password when using CANopen PDO

Causes	Checking Method	Corrective Actions
When entering parameters via CAN, parameters are password-protected. Users have to decode the password first.	Check if the specified object enters the wrong password when PDO is receiving or sending.	NMT: Reset node or 0x6040.Fault Reset

AL170 : CANopen Heartbeat or NodeGuarding error

Causes	Checking Method	Corrective Actions
CANopen communication breaks.	Check if CANopen communication and connection is normal.	NMT:Reset node or 0x6040.Fault Reset

AL180 : CANopen Heartbeat or NodeGuarding error

Causes	Checking Method	Corrective Actions
CANopen communication breaks.	Check if CANopen communication and connection is normal.	NMT:Reset node or 0x6040.Fault Reset

AL185 : Abnormal CAN Bus hardware

Causes	Checking Method	Corrective Actions
Abnormal CAN Bus hardware	<ol style="list-style-type: none"> 1. Check if the communication cable of CAN Bus is connected. 2. Check the communication quality. (It is suggested to use common grounding and shielded cable) 	NMT: Reset node or re-servo on

AL186 : Bus off

Causes	Checking Method	Corrective Actions
CAN Bus transfer error	Check if the communication is correctly connected or if there is any interference.	Change the communication cable or eliminate the noise.
	The number of slave station is excessive and the communication cycle period is too short.	Lengthen the communication cycle.

AL201 : An error occurs when loading CANopen data

Causes	Checking Method	Corrective Actions
An error occurs when loading CANopen data	<ol style="list-style-type: none"> 1. If the alarm is cleared when cycling power on the servo drive, it means the data error occurs instantaneously when accessing in the previous time. 2. If the error still exists after cycling power on the servo drive, it means the data in EEPROM is damaged. It has to enter the correct value again. The method is as the followings: <ol style="list-style-type: none"> a. If the user desires to enter the default value, it can set P2-08 to 30, 28 or CANopen object as 0x1011. b. If the user desires to enter the current value, it can set CANopen object to 0x1010. (Please refer to CANopen description.) 	DI.ARST, CANopen 0x1011 Restore default parameter

AL207 : Parameter group of PR#8 is out of the range

Causes	Checking Method	Corrective Actions
The parameter group of command source exceeds the range.	Writing parameter via PR procedure: The parameter group of command source exceeds the range.	DI.Alm Reset or write 0 into P0-01

AL209 : Parameter number of PR#8 is out of the range

Causes	Checking Method	Corrective Actions
The parameter number of command source exceeds the range.	Writing parameter via PR procedure: The parameter number of command source exceeds the range.	DI.Alm Reset or write 0 into P0-01

AL213 ~ AL217 : An error occurs when writing parameter via PR

Causes	Checking Method	Corrective Actions
PR commands TYPE 8 Error occurs when writing parameters.	AL213: parameter exceeds the range	DI.Alm Reset or P0-01 = 0
	AL215: the parameter is read-only	
	AL217: Servo On or invalid value	Re-adjust PR command and parameters.

AL231 : The setting of monitor item of PR#8 is out of the range

Causes	Checking Method	Corrective Actions
The monitor item of the command source exceeds the range.	Writing parameter via PR procedure: The monitor item number of command source exceeds the range.	DI.Alm Reset or write 0 into P0-01

AL235 : PR command overflows

Causes	Checking Method	Corrective Actions
PR command error	<p>Incremental type: PR mode continuously operates in one direction and causes feedback register (FB_PUU) overflows. And the coordinate system cannot reflect the correct position. If issuing the absolute positioning command at this time, the error will occur.</p> <p>Absolute type: The error occurs in following situations:</p> <ol style="list-style-type: none"> 1. Feedback register (FB_PUU) overflows 2. After P1-01.Z is modified, the system neither returns to the original point nor conducts homing procedure. 3. It does not conduct homing procedure after the E-gear ratio is modified (P1-44 and P1-45). 4. Returning to the original point is triggered and the homing procedure is not complete. 5. When AL060 and AL062 occur, please use the scope to check if the feedback position has overflowed. Check steps 1- 4 above and perform the homing procedure. 	Conduct homing procedure.

AL237 : Indexing coordinate is undefined

Causes	Checking Method	Corrective Actions
When executing indexing function, if the index positioning command is directly executing before defining the start point of index coordinate, the alarm will therefore occur.	Indexing coordinate is undefined and then execute index positioning command.	<ol style="list-style-type: none"> 1. Before executing indexing function, please conduct homing first so as to avoid this alarm. 2. When the alarm occurs, please use DI:Alm Reset or write 0 into P0-01 to clear the alarm. 3. The alarm can be cleared when it is Servo ON.

AL245 : PR Positioning Timeout

Causes	Checking Method	Corrective Actions
PR positioning command is triggered and the execution time for positioning is too long.	Check the causes of not completing the PR command, such as the waiting conditions are not set or not triggered.	When the alarm occurs, please use DI:Alm Reset or write 0 into P0-01 to clear the alarm.

AL249 : The number of PR command exceeds the limit

Causes	Checking Method	Correction Actions
The triggered PR path exceeds 63.	Check if the PR command jumps to the path that exceeds the range and if the PR command format is correct.	When the alarm occurs, please use DI:Alm Reset or write 0 into P0-01 to clear the alarm.

AL283 : Forward Software Limit

Causes	Checking Method	Corrective Actions
Forward software limit	Forward Software Limit is determined by the position command, not the actual feedback position. It is because the command will arrive first and then the feedback. When the protection function is activated, the actual position might not over the limit. Therefore, setting an appropriate decelerating time could satisfy the demand. Please refer to the description of parameter P5-03.	NMT: Reset node or 0x6040.Fault Reset

AL285 : Reverse Software Limit

Causes	Checking Method	Corrective Actions
Reverse software limit	Reverse Software Limit is determined by the position command, not the actual feedback position. It is because the command will arrive first and then the feedback. When the protection function is activated, the actual position might not over the limit. Therefore, setting an appropriate decelerating time could satisfy the demand. Please refer to the description of parameter P5-03.	NMT: Reset node or 0x6040.Fault Reset

AL289 : Feedback position counter overflows

Causes	Checking Method	Corrective Actions
Feedback position counter overflows.	<ol style="list-style-type: none"> 1. Set the gear ratio properly according to the total traveling distance of the absolute motor and the actual application requirements to avoid the feedback position counter overflow. 2. If you have set P2-69.Z to 1 to disable the index coordinate overflow function, set P2-70 [Bit 2] to 1. 	NMT: Reset node or 0x6040.Fault Reset

AL291 : Servo Off error

Causes	Checking Method	Corrective Actions
Servo Off error	<ol style="list-style-type: none"> 1. Check if the wiring of DI.SERVO ON is correct. 2. Check if the controller switch the servo to on too early. 	NMT: Reset node or 0x6040.Fault Reset

AL301 : CANopen fails to synchronize

Causes	Checking Method	Corrective Actions
CANopen fails to synchronize.	<ol style="list-style-type: none"> 1. Check if the communication quality of the circuit is bad. 2. Check if the controller sends SYNC signal successfully. 3. Check if the setting of P3-09 is reasonable. (It is better to use the default value.) 	NMT: Reset node or 0x6040.Fault Reset

AL302 : The synchronized signal of CANopen is sent too fast

Causes	Checking Method	Corrective Actions
The synchronized signal of CANopen is sent too fast.	<ol style="list-style-type: none"> 1. Check if synchronized cycle 0x1006 is the same as the setting of controller. 2. Check if the setting of P3-09 is reasonable. (It is better to use the default value.) 3. Ensure the correct time sequence of sending packets from the controller. 	NMT: Reset node or 0x6040.Fault Reset

AL303 : The synchronized signal of CANopen is sent too slow

Causes	Checking Method	Corrective Actions
The synchronized signal of CANopen is sent too slow.	<ol style="list-style-type: none"> 1. Check if the communication quality of the circuit is bad. 2. Check if synchronized cycle 0x1006 is the same as the setting of controller. 3. Check if the setting of P3-09 is reasonable. (It is better to use the default value.) 4. Ensure the correct time sequence of sending packets from the controller. 	NMT: Reset node or 0x6040.Fault Reset

AL304 : CANopen IP command fails

Causes	Checking Method	Corrective Actions
CANopen IP command fails.	The computing time in IP mode takes too long. Please disable the USB monitoring function.	NMT: Reset node or 0x6040.Fault Reset

AL305 : SYNC Period is in error

Causes	Checking Method	Corrective Actions
SYNC Period is in error.	Examine the content of 0x1006.If it is smaller than or equals to 0, the alarm will occur.	NMT: Reset node or 0x6040.Fault Reset

AL35F : Emergency Stop (during deceleration)

Causes	Checking Method	Corrective Actions
The DI (0x47) is rising-edge triggered and the motor decelerates to 0 before AL3CF occurs.	Check if the DI (0x47) is accidentally triggered because of the parameter setting.	Cycle power on the servo drive.

AL380 : Position deviation alarm

Causes	Checking Method	Corrective Actions
DO.MC_OK is ON and becomes OFF.	<p>Please refer to the description of parameter P1-48.</p> <p>After DO.MC_OK has been ON, DO.MC_OK becomes OFF because DO.TPOS turns OFF.</p> <p>The position of the motor might be deviated by the external force after positioning. This alarm can be cleared by P1-48.Y=0.</p>	DI.Alm Reset or P0-01= 0

AL3CF : Emergency Stop

Causes	Checking Method	Corrective Actions
After AL35F occurs, the motor decelerates to 0.	Check if the DI (0x47) is accidentally triggered because of the parameter setting.	Cycle power on the servo drive.

AL3F1 : Absolute index coordinate undefined

Causes	Checking Method	Corrective Actions
<p>This alarm occurs when you use the communication type servo drives (CANopen, DMCNET, and EtherCAT) with incremental type motors and position overflow occurs, and you send an absolute positioning command without first executing the homing procedure.</p> <p>Causes:</p> <ol style="list-style-type: none"> 1. The absolute coordinate system has not been created. 2. Overflow occurs because the motor keeps rotating in the same direction. 	<ol style="list-style-type: none"> 1. Create an absolute coordinate system. 2. Set the origin again. 	Set the origin again.

AL400 : Index coordinates error

Causes	Checking Method	Corrective Actions
Setting of P2-52 is wrong	Check if the setting of P2-52 is within the range. If the setting value is too small, it would cause index coordinates error.	Re-adjust the value of P5-52 until it is appropriate.

AL401 : Receives NMT reset command when Servo On

Causes	Checking Method	Corrective Actions
Receives NMT reset command when Servo On	Check if the servo drive receives NMT reset command when Servo On.	NMT: Reset node or 0x6040.Fault Reset

AL404 : Value of PR special filter setting is too big

Causes	Checking Method	Corrective Actions
Inner position error overflows.	Check the setting of P1-22. If the value is too high, the following error exceeds the allowable range faster.	Re-adjust the value of P1-22 until it is appropriate.

AL500 : STO function is enabled

Causes	Checking Method	Corrective Actions
Safe torque off function (STO) is enabled.	Safe torque off function (STO) is enabled. Please check why it is enabled.	Use DI.ARST or 0x6040.Fault Reset, or set P0-01 to 0.

AL501 : STO_A loss (signal loss or signal error)

Causes	Checking Method	Corrective Actions
Loss of STO_A signal or STO_A and STO_B signals are not synchronized for more than 1 sec.	Check if the wiring of STO_A is correct.	Use DI.ARST or 0x6040.Fault Reset, or set P0-01 to 0.

AL502 : STO_B lost (signal loss or signal error)

Causes	Checking Method	Corrective Actions
Loss of STO_B signal or STO_A and STO_B signals are not synchronized for more than 1 sec.	Make sure the wiring of STO_B is correct.	Use DI.ARST or 0x6040.Fault Reset, or set P0-01 to 0.

AL503 : STO_error

Causes	Checking Method	Corrective Actions
An error occurs during STO self-diagnosis.	N/A	It might be that the STO circuit is causing the error. Please contact the distributor.

AL555 : System failure

Causes	Checking Method	Corrective Actions
DSP processing error	N/A	If AL555 occurs, do not do anything and send the drive back to Delta.

10.5 Corrective Actions after the Alarm Occurs

AL001	: Over current	Turn DI.ARST on to clear the alarm.
AL002	: Over voltage	Turn DI.ARST on to clear the alarm.
AL003	: Undervoltage	Cycle power on the servo drive to clear the alarm. For the alarm to clear automatically after the voltage returns to normal, please set with P2-66 Bit2.
AL004	: The magnetic field of the motor is abnormal	The alarm can be cleared after power cycling.
AL005	: Regeneration error	Turn DI.ARST on to clear the alarm.
AL006	: Overload	Turn DI.ARST on to clear the alarm.
AL007	: Excessive speed deviation	Turn DI.ARST on to clear the alarm.
AL008	: Abnormal pulse command	Turn DI.ARST on to clear the alarm.
AL009	: Excessive deviation of position control	Turn DI.ARST on to clear the alarm.
AL011	: Encoder error	The alarm can be cleared after power cycling.
AL012	: Adjustment error	The alarm can be cleared when removing CN1 wiring and execute auto adjustment.
AL013	: Emergency stop	The alarm can be cleared automatically after turning DI.EMGS off.
AL014	: Reverse limit error	Turn DI.ARST on or Servo Off to clear the alarm. The alarm also can be cleared when the motor operates backwards.
AL015	: Forward limit error	Turn DI.ARST on or Servo Off to clear the alarm. The alarm also can be cleared when the motor operates backwards.
AL016	: The temperature of IGBT is abnormal	Turn DI.ARST on to clear the alarm.
AL017	: Abnormal EEPROM	If the alarm occurs, then parameter reset is a must. And re-servo on again. If it happens during the operation, please turn DI.ARST on to clear the alarm.
AL018	: Abnormal signal output	Turn DI.ARST on to clear the alarm.
AL019	: Serial communication error	Turn DI.ARST on to clear the alarm.

AL020	: Serial communication timeout	Turn DI.ARST on to clear the alarm.
AL022	: Main circuit power leak phase	Turn DI.ARST on to clear the alarm.
AL023	: Early warning for overload	Turn DI.ARST on to clear the alarm.
AL024	: Encoder initial magnetic field error	The alarm can be cleared after power cycling.
AL025	: The internal of the encoder is in error	The alarm can be cleared after power cycling.
AL026	: The encoder is in error	The alarm can be cleared after power cycling.
AL027	: The internal of the motor is in error	The alarm can be cleared after power cycling.
AL028	: The encoder is over voltage or the internal of the encoder is in error	The alarm can be cleared after power cycling.
AL029	: Gray code error	The alarm can be cleared after power cycling.
AL030	: Motor crash error	Turn DI.ARST on to clear the alarm.
AL031	: Incorrect wiring of the motor power line U, V, W, GND	Turn DI.ARST on to clear the alarm.
AL034	: Internal communication of the encoder is in error	The alarm can be cleared after power cycling.
AL035	: Encoder temperature exceeds the protective range	The temperature sensor of motor shall below 100°C (212°F). And the alarm can be cleared after cycling power on.
AL040	: Excessive deviation of full closed-loop position control	Turn DI.ARST on to clear the alarm.
AL041	: Linear scale communication is cut off	Turn DI.ARST on to clear the alarm.
AL042	: Analog input voltage error	Turn DI.ARST on to clear the alarm.
AL044	: Warning of servo drive function overload	Set P2-66 Bit4 to 1 and then cycle power on the servo drive.
AL045	: Wrong setting of E-gear ratio	The alarm can be cleared after correctly setting up the parameter.
AL060	: The absolute position is lost	The alarm can be cleared after power cycling.
AL061	: Encoder under voltage	Change the battery and AL061 will be cleared automatically.
AL062	: The multi-turn if absolute encoder overflows	The alarm can be cleared after power cycling.
AL067	: Encoder temperature warning	Turn DI.ARST on to clear the alarm.

AL068	: Absolute data transmitted via I/O is in error	The alarm can be cleared after power cycling.
AL069	: Wrong motor type	Set P2-69 to 0 and then cycle power on the servo drive.
AL06A	: The absolute coordinate has not been initialized	The alarm can be cleared after creating the absolute origin coordinate.
AL070	: Encoder does not complete the command which is issued by servo drive	The alarm can be cleared after power cycling.
AL072	: Encoder overspeed	Turn DI.ARST on to clear the alarm.
AL073	: Encoder memory error	Turn DI.ARST on to clear the alarm.
AL074	: Absolute encoder single turn position error	Turn DI.ARST on to clear the alarm.
AL075	: Absolute encoder position error	Turn DI.ARST on to clear the alarm.
AL077	: Encoder computing error	Turn DI.ARST on to clear the alarm.
AL079	: Encoder parameter error	Turn DI.ARST on to clear the alarm.
AL07A	: Loss of encoder Z pulse	Cycle power on the servo drive to clear the alarm.
AL07B	: Encoder memory busy	Turn DI.ARST on to clear the alarm.
AL07C	: Command to clear the absolute position is issued when the motor speed is over 200 rpm	Perform the position reset when the motor speed is under 200 rpm.
AL07D	: Servo drive power is cycled before AL07C is cleared	Turn DI.ARST on to clear the alarm.
AL07E	: Encoder clearing procedure error	Turn DI.ARST on to clear the alarm.
AL083	: Servo drive outputs excessive current	Turn DI.ARST on to clear the alarm.
AL085	: Regeneration error	Turn DI.ARST on to clear the alarm.
AL086	: Input voltage is too high	Turn DI.ARST on to clear the alarm.
AL095	: The servo drive does not connect to external regenerative resistor	Turn DI.ARST on to clear the alarm.
AL099	: DSP firmware upgrade	Firstly set P2-08 to 30. Then set it to 28. And the alarm will be cleared after power cycling.
AL111	: CANopen SDO receives buffer overflow	NMT: Reset node or 0x6040.Fault Reset
AL112	: CANopen PDO receives buffer overflow	NMT: Reset node or 0x6040.Fault Reset
AL121	: Index error occurs when accessing CANopen PDO	NMT: Reset node or 0x6040.Fault Reset

AL122	: Sub-Index error occurs when accessing CANopen PDO	NMT: Reset node or 0x6040.Fault Reset
AL123	: Data Size error occurs when accessing CANopen PDO	NMT: Reset node or 0x6040.Fault Reset
AL124	: Data range error occurs when accessing CANopen PDO	NMT: Reset node or 0x6040.Fault Reset
AL125	: CANopen PDO is read-only and write-protected.	NMT: Reset node or 0x6040.Fault Reset
AL126	: CANopen PDO is not allowed in PDO	NMT: Reset node or 0x6040.Fault Reset
AL127	: CANopen PDO is write-protected when Servo On	NMT: Reset node or 0x6040.Fault Reset
AL128	: Error occurs when reading CANopen PDO via EEPROM	NMT: Reset node or 0x6040.Fault Reset
AL129	: Error occurs when writing CANopen PDO via EEPROM	NMT: Reset node or 0x6040.Fault Reset
AL130	: The accessing address of EEPROM is out of range when using CANopen PDO	NMT: Reset node or 0x6040.Fault Reset
AL131	: CRC of EEPROM calculation error occurs when using CANopen PDO	NMT: Reset node or 0x6040.Fault Reset
AL132	: Enter the incorrect password when using CANopen PDO	NMT: Reset node or 0x6040.Fault Reset
AL170	: Heartbeat or NodeGuarding error	NMT: Reset node or 0x6040.Fault Reset
AL180	: Heartbeat or NodeGuarding error	NMT: Reset node or 0x6040.Fault Reset
AL185	: Abnormal CAN Bus hardware	NMT: Reset node or power cycling
AL186	: CAN bus off	NMT: Reset node or 0x6040.Fault Reset
AL201	: An error occurs when loading CANopen data	Turn DI.ARST on to clear the alarm. CANopen 0x1011 Restore default parameter
AL207	: Parameter group of PR#8 is out of range	Turn DI.ARST on to clear the alarm or set P0-01 to 0.
AL209	: Parameter number of PR#8 is out of range	Turn DI.ARST on to clear the alarm or set P0-01 to 0.
AL213	: An error occurs when writing parameter via PR : exceeds the range	Turn DI.ARST on to clear the alarm or set P0-01 to 0.

AL215	: An error occurs when writing parameter via PR : read-only	Turn DI.ARST on to clear the alarm or set P0-01 to 0.
AL217	: An error occurs when writing parameter via PR : parameter locked	Re-adjust PR command and parameter.
AL231	: The setting of monitor item of PR#8 is out of range	Turn DI.ARST on to clear the alarm or set P0-01 to 0.
AL235	: PR command overflows	Execute the homing procedure.
AL237	: Indexing coordinate is undefined	Turn DI.ARST on to clear the alarm or set P0-01 to 0.
AL245	: PR Positioning Timeout	Turn DI.ARST on to clear the alarm or set P0-01 to 0; cycle the power.
AL249	: The number of PR command exceeds the limit	Turn DI.ARST on to clear the alarm or set P0-01 to 0; cycle the power.
AL283	: Forward Software Limit	NMT: Reset node or 0x6040.Fault Reset
AL285	: Reverse Software Limit	NMT: Reset node or 0x6040.Fault Reset
AL289	: Feedback position counter overflows	NMT: Reset node or 0x6040.Fault Reset
AL291	: Servo Off error	NMT: Reset node or 0x6040.Fault Reset
AL301	: CANopen fails to synchronize	NMT: Reset node or 0x6040.Fault Reset
AL302	: The synchronized signal of CANopen is sent too fast	NMT: Reset node or 0x6040.Fault Reset
AL303	: The synchronized signal of CANopen is sent too slow	NMT: Reset node or 0x6040.Fault Reset
AL304	: CANopen IP command is failed	NMT: Reset node or 0x6040.Fault Reset
AL305	: SYNC Period is in error	NMT: Reset node or 0x6040.Fault Reset
AL380	: Position Deviation Alarm	Turn DI.ARST on to clear the alarm or set P0-01 to 0.
AL400	: Index coordinates error	Turn DI.ARST on to clear the alarm.
AL401	: NMT Reset command is received when Servo On	Turn DI.ARST on to clear the alarm.
AL404	: Value of PR special filter setting is too big	Turn DI.ARST on to clear the alarm.

AL500	: STO function is enabled	Use DI.ARST or 0x6040.Fault Reset, or set P0-01 to 0.
AL501	: STO_A loss (signal loss or signal error)	Use DI.ARST or 0x6040.Fault Reset, or set P0-01 to 0.
AL502	: STO_B lost (signal loss or signal error)	Use DI.ARST or 0x6040.Fault Reset, or set P0-01 to 0.
AL503	: STO_error	STO circuit error; please contact the distributor.
AL555	: System failure	N/A

(This page is intentionally left blank.)



Chapter 11 Specifications

11.1 Specifications of Servo Drives (ASDA-A2 Series)

11.1.1 ASDA-A2 220V Series

ASDA-A2 Series		100 W	200 W	400 W	750 W	1 kW	1.5 kW	2 kW	3 kW	4.5 kW	5.5 kW	7.5 kW	11 kW	15 kW
		01	02	04	07	10	15	20	30	45	55	75	1B	1F
Main Circuit Power Supply	Phase / Voltage	Single-phase / Three-phase 220 V _{AC}						Three-phase 220 V _{AC}						
	Permissible Voltage	Single-phase / Three-phase 200 to 230 V _{AC} , -15% to 10%						Three-phase 200 to 230 V _{AC} , -15% to 10%						
	Input Current (3PH) Unit: Arms	0.39	1.11	1.86	3.66	4.68	5.9	8.76	9.83	17.5	19.4	26.3	48	63
	Input Current (1PH) Unit: Arms	0.69	1.92	3.22	6.78	8.88	10.3	-	-	-	-	-	-	-
	Continuous Output Current Unit: Arms	0.9	1.55	2.6	5.1	7.3	8.3	13.4	19.4	32.5	40	47.5	54.4	70
Cooling method		Natural cooling				Fan Cooling								
Encoder Resolution (Servo Drive Resolution)		Incremental type: 20-bit; absolute type: 17-bit (1280000 p/rev)												
Main Circuit Control		SVPWM (Space Vector Pulse Width Modulation) Control												
Control Mode		Auto / Manual												
Regenerative Resistor		None		Built-in							External			
Position Control Mode	Max. Input Pulse Frequency (except DMCNET mode)	Line driver: 500 Kpps / 4 Mpps; open collector: 200 Kpps												
	Pulse Type (except DMCNET mode)	Pulse + Direction, A phase + B phase, CCW pulse + CW pulse												
	Command Source	External pulse (except DMCNET mode) / Register												
	Smoothing Strategy	Low-pass and P-curve filter												
	E-gear ratio	E-gear ratio N/M multiple (1/50 < N/M < 25600) N: 1 to (2 ²⁹ -1), M: 1 to (2 ³¹ -1)												
	Torque Limit	Parameter settings												
	Feed Forward Compensation	Parameter settings												
Speed Control Mode	Analog Command Input (except DMCNET mode)	Voltage Range	0 to ±10 V _{DC}											
		Input Resistance	10 kΩ											
		Time Constant	2.2 us											
	Speed Control Range *1	1 : 5000										1 : 3000		1 : 2000
	Command Source	External analog command (except DMCNET mode) / Register												
	Smoothing Strategy	Low-pass and S-curve filter												
Torque Limit	Via parameter settings or analog input (except DMCNET mode)													
Bandwidth	Maximum 1 kHz													

ASDA-A2 Series		100 W	200 W	400 W	750 W	1 kW	1.5 kW	2 kW	3k W	4.5 kW	5.5 kW	7.5 kW	11 kW	15 kW
		01	02	04	07	10	15	20	30	45	55	75	1B	1F
	Speed Accuracy *2	0.01% or less at 0 to 100% load fluctuation												
		0.01% or less at ±10% power fluctuation												
		0.01% or less at 0°C to 50°C ambient temperature fluctuation												
Torque Control Mode	Analog Command Input (DMCNET mode is not included)	Voltage Range	0 to ±10 V _{DC}											
		Input Resistance	10 kΩ											
		Time Constant	2.2 us											
	Command Source	External analog command (except DMCNET mode) / Register												
	Smoothing Strategy	Low-pass filter												
	Speed Limit	Via parameter settings or analog input (except DMCNET mode)												
	Analog Monitor Output	Monitor signal can be set by parameters (Output voltage range: ±8V)												
Digital Input/Output	Input	Servo on, Fault reset, Gain switch, Pulse clear, Zero clamp, Command input reverse control, Internal position command trigger, Torque limit, Speed limit, Internal position command selection, Motor stop, Speed command selection, Speed / position mode switching, Speed / torque mode switching, Torque / position mode switching, PT / PR command switching, Emergency stop, Positive / negative limit, Original point, Forward / reverse operation torque limit, Homing activated, E-CAM engage, Forward / reverse JOG input, Event trigger, E-gear N selection, Pulse input prohibition *DMCNET mode is not included for the DI mentioned above. When applying DMCNET mode, it is suggested to use communication for DI input. Its DI only supports emergency stop, forward/reverse limit and homing.												
	Output	A, B, Z Line Driver output Servo on, Servo ready, Zero speed, Target speed reached, Target position reached, torque limiting, Servo alarm, Brake control, Homing completed, Early warning for overload, Servo warning, Position command overflows, Software negative limit (reverse direction), Software positive limit (forward direction), Internal position command completed, Capture procedure completed, Servo procedure completed, Master position area of E-CAM												
Protective Function	Over current, Overvoltage, Under voltage, Overheat, Regeneration error, Overload, Excessive speed deviation, Excessive position deviation, Encoder error, Adjustment error, Emergency stop, Negative / positive limit error, Excessive deviation of full-closed loop control, Serial communication error, Rst leak phase, Serial communication timeout, Short-circuit protection of terminal U, V, W and CN1, CN2, CN3													
Communication Interface	RS-232 / RS-485 / CANopen / USB / DMCNET													
Environment	Installation Site	Indoors (avoid the direct sunlight), no corrosive fog (avoid fume, flammable gas, and dust)												
	Altitude	Altitude 1,000 m (3280.84 ft) or lower above sea level												
	Atmospheric pressure	86 kPa to 106 kPa												
	Operating Temperature	0°C to 55°C (32°F to 131°F) (If operating temperature is above 45°C (113°F), forced cooling will be required)												
	Storage Temperature	-20°C to 65°C (-4°F to 149°F)												
	Humidity	Under 0 to 90% RH (non-condensing)												
	Vibrating	9.80665 m/s ² (1 G) less than 20 Hz, 5.88 m/s ² (0.6 G) 20 to 50 Hz												
	IP Rating	IP20												
	Power System	TN System*3												

ASDA-A2 Series		100 W	200 W	400 W	750 W	1 kW	1.5 kW	2 kW	3k W	4.5 kW	5.5 kW	7.5 kW	11 kW	15 kW
		01	02	04	07	10	15	20	30	45	55	75	1B	1F
	Approvals	IEC/EN 61800-5-1, UL 508C, C-tick   												



Note:

- *1 Within the rated load, the speed ratio is: the minimum speed (smooth operation) / rated speed.
- *2 When the command is the rated speed, the velocity correction ratio is: (rotational speed with no load – rotational speed with full load) / rated speed.
- *3 Please refer to section 11.4 for overload features.
- *4 TN system: The neutral point of the power system connects to the ground directly. The exposed metal components connect to the ground via the protective earth conductor.
- *5 Please use a single-phase three-wire power system for the single-phase power model.

11.1.2 ASDA-A2 400V Series

ASDA-A2 Series		750 W	1 kW	1.5 kW	2 kW	3 kW	4.5 kW	5.5 kW	7.5 kW	11kW	15kW	
		07	10	15	20	30	45	55	75	1B	1F	
Power	Input Voltage	24 V _{DC} , ±10%										
	Input Current	0.89 A			1.18 A				1.66 A	2 A		
	Input Power	21.4 W			28.2 W				39.85 W	48 W		
Main Circuit Power		Three-phase, 380 to 480 V _{AC} , ±10%										
Input Current (3PH) Unit: Arms		2.22	3.02	4.24	5.65	8.01	11.9	14.1	17.27	28.95	39.47	
Continuous Output Current Unit: Arms		3.07	3.52	5.02	6.66	11.9	20	22.04	28.39	28.1	38.65	
Instantaneous Max. Output Current Unit: Arms		9.21	9.86	10.04	18.65	33.32	44	48.49	62.46	61.82	85.03	
Cooling method		Fan Cooling										
Encoder Resolution (Servo Drive Resolution)		Incremental type: 20-bit (1280000 p/rev); Absolute type: 17-bit (1280000 p/rev)										
Main Circuit Control		SVPWM (Space Vector Pulse Width Modulation) Control										
Control Modes		Auto / Manual										
Regenerative Resistor		Built-in				External						
Position Control Mode	Max. Input Pulse Frequency (except DMCNET mode)	Line driver: 500 Kpps / 4 Mpps; Open collector: 200 Kpps										
	Pulse Type (except DMCNET mode)	Pulse + Direction, A phase + B phase, CCW pulse + CW pulse										
	Command Source	External pulse train (except DMCNET mode) / Internal parameters										
	Smoothing Strategy	Low-pass and P-curve filter										
	E-gear ratio	E-gear ratio: N/M multiple (1/50 < N/M < 25600) N: 1 to (2 ²⁹ -1) / M: 1 to (2 ³¹ -1)										
	Torque Limit	Parameter settings										
	Feed Forward Compensation	Parameter settings										
Speed Control Mode	Analog Command Input (except DMCNET mode)	Voltage Range	0 to ±10 V _{DC}									
		Input Resistance	10 kΩ									
		Time Constant	2.2 us									
	Speed Control Range *1	1 : 5000					1 : 3000					
	Command Source	External analog command (DMCNET is not included) / Register										
	Smoothing Strategy	Low-pass and S-curve filter										
	Torque Limit	Via parameter settings or analog input (DMCNET mode is not included)										
Bandwidth	Maximum 1 kHz											

ASDA-A2 Series			750 W	1 kW	1.5 kW	2 kW	3 kW	4.5 kW	5.5 kW	7.5 kW	11kW	15kW
			07	10	15	20	30	45	55	75	1B	1F
Speed Control Mode	Speed Accuracy ^{*2}		0.01% or less at 0 to 100% load fluctuation									
			0.01% or less at ±10% power fluctuation									
			0.01% or less at 0°C to 50°C (35°F to 122°F) ambient temperature fluctuation									
Torque Control Mode	Analog Command Input (except DMCNET mode)	Voltage Range	0 to ±10 V _{DC}									
		Input Resistance	10 kΩ									
		Time Constant	2.2 us									
	Command Source		External analog command (except DMCNET mode) / Register									
	Smoothing Strategy		Low-pass filter									
	Speed Limit		Via parameter settings or analog input (except DMCNET mode)									
Analog Monitor Output			Monitor signal can set by parameters (Output voltage range: ±8V)									
Digital Input/Output	Input		Servo on, Fault reset, Gain switching, Pulse clear, Zero speed CLAMP, Command input reverse control, Command triggered, Torque limit., Speed limit, Position command selection, Motor stop, Speed command selection, Position / Speed mode switching, Speed / Torque mode switching, Torque / Position mode switching, PT / PR command switching, Emergency stop, Forward / Reverse inhibit limit, Original point for homing, Forward / Reverse operation torque limit, Homing activated, E-Cam engage, Forward / Reverse JOG input, Event trigger PR command, Electronic gear ratio (Numerator) selection and Pulse inhibit input *DMCNET mode is not included for the DI mentioned above. When applying DMCNET mode, it is suggested to use communication for DI input. Its DI only supports emergency stop, forward/reverse limit and homing.									
	Output		A, B, Z Line Driver output Servo on, Servo ready, Zero speed, Target speed reached, Target position reached, torque limiting, Servo alarm, Brake control, Homing completed, Early warning for overload, Servo warning, Position command overflows, Software negative limit (reverse direction), Software positive limit (forward direction), Internal position command completed, Capture procedure completed, Servo procedure completed, Master position area of E-CAM									
Protective Function			Overcurrent, Overvoltage, Undervoltage, Overheat, Regeneration error, Overload, Excessive speed deviation, Excessive position deviation, Encoder error, Adjustment error, Emergency stop, Negative / positive limit error, Excessive deviation of full-closed loop control, Serial communication error, Rst leak phase, Serial communication timeout, Short-circuit protection of terminal U, V, W and CN1, CN2, CN3									
Communication Interface			RS-232 / RS-485 / CANopen / USB / DMCNET									
Environment	Installation Site		Indoor (avoid the direct sunlight), no corrosive fog (avoid fume, flammable gas, and dust)									
	Altitude		Altitude 1,000 m (3280.84 ft) or lower above sea level									
	Atmospheric pressure		86 kPa to 106 kPa									
	Operating Temperature (°C)		0°C to 55°C (32°F to 131°F) (If operating temperature is above 45°C (113°F), forced air circulation will be required)									
	Storage Temperature (°C)		-20°C to 65°C (-4°F to 149°F)									
	Humidity		0 to 90% (non-condensing)									
Vibrating		9.80665 m/s ² (1 G) less than 20 Hz, 5.88 m/s ² (0.6 G) 20 to 50 Hz										

ASDA-A2 Series		750 W	1 kW	1.5 kW	2 kW	3 kW	4.5 kW	5.5 kW	7.5 kW	11kW	15kW
		07	10	15	20	30	45	55	75	1B	1F
	IP Rating	IP20									
	Power System	TN System ^{*3}									
	Approvals	IEC/EN 61800-5-1, UL 508C, C-tick   									

Note:

- *1 Within the rated load, the speed ratio is: the minimum speed (smooth operation) / rated speed.
- *2 When the command is the rated speed, the velocity correction ratio is: (rotational speed with no load – rotational speed with full load) / rated speed.
- *3 Please refer to section 11.4 for overload features.
- *4 TN system: The neutral point of the power system connects to the ground directly. The exposed metal components connect to the ground via the protective earth conductor.

11.2 Specifications of Servo Motors (ECMA Series)

11.2.1 ECMA 220V Series

Low Inertia Series

ECMA Series	C104	C△04	C△06		C△08		C△09	
	0F	01	02	04□S	04	07	07	10
Rated power (kW)	0.05	0.1	0.2	0.4	0.4	0.75	0.75	1.0
Rated torque (N-m) ^{*1}	0.159	0.32	0.64	1.27	1.27	2.39	2.39	3.18
Max. torque (N-m)	0.477	0.96	1.92	3.82	3.82	7.16	7.14	8.78
Rated speed (r/min)	3000						3000	
Max. speed (r/min)	5000						3000	
Rated current (Arms)	0.69	0.90	1.55	2.60	2.60	5.10	3.66	4.25
Max. instantaneous current (Arms)	2.05	2.70	4.65	7.80	7.80	15.3	11.0	12.37
Power rating (kW/s)	12.27	27.7	22.4	57.6	24.0	50.4	29.6	38.6
Rotor inertia (× 10 ⁻⁴ kg.m ²)	0.0206	0.037	0.177	0.277	0.68	1.13	1.93	2.62
Mechanical constant (ms)	1.2	0.75	0.80	0.53	0.74	0.63	1.72	1.20
Torque constant-KT (N-m/A)	0.23	0.36	0.41	0.49	0.49	0.47	0.65	0.75
Voltage constant-KE (mV/(r/min))	9.8	13.6	16.0	17.4	18.5	17.2	24.2	27.5
Armature resistance (Ohm)	12.7	9.30	2.79	1.55	0.93	0.42	1.34	0.897
Armature inductance (mH)	26.0	24.0	12.07	6.71	7.39	3.53	7.55	5.7
Electric constant (ms)	2.05	2.58	4.30	4.30	7.96	8.36	5.66	6.35
Insulation class	Class A (UL), Class B (CE)							
Insulation resistance	> 100 MΩ, DC 500V							
Insulation strength	1.8k V _{AC} , 1 sec							
Weight (kg) (without brake)	0.42	0.5	1.2	1.6	2.1	3.0	2.9	3.8
Weight (kg) (with brake)	--	0.8	1.5	2.0	2.9	3.8	3.69	5.5
Radial max. loading (N)	78.4	78.4	196	196	245	245	245	245
Axial max. loading (N)	39.2	39.2	68	68	98	98	98	98
Power rating (kW/s) (with brake)	--	25.6	21.3	53.8	22.1	48.4	29.3	37.9
Rotor inertia (× 10 ⁻⁴ kg.m ²) (with brake)	--	0.04	0.19	0.30	0.73	1.18	1.95	2.67
Mechanical constant (ms) (with brake)	--	0.81	0.85	0.57	0.78	0.65	1.74	1.22
Brake holding torque [Nt-m (min)] ^{*2}	--	0.3	1.3	1.3	2.5	2.5	2.5	2.5
Brake operating voltage	24V _{DC} ± 10%							

ECMA Series	C104	C△04	C△06		C△08		C△09	
	0F	01	02	04□S	04	07	07	10
Brake power consumption (at 20°C) [W]	--	7.9	7.2	7.2	8.4	8.4	8.4	8.4
Brake release time [ms (Max)]	--	20	20	20	40	40	40	40
Brake pull-in time [ms (Max)]	--	35	70	70	70	70	70	70
Vibration grade (μm)	15							
Operating temperature (°C)	0°C to 40°C (32°F to 104°F)							
Storage temperature (°C)	-10°C to 80°C (14°F to 170°F)							
Operating humidity	20% to 90% RH (non-condensing)							
Storage humidity	20% to 90% RH (non-condensing)							
Vibration capacity	2.5 G							
IP Rating	IP65 (when waterproof connectors are used, or when an oil seal is used to be fitted to the rotating shaft (an oil seal model is used))							
Approvals								

Note:

*1. The rated torque is the continuous permissible torque between 0 to 40°C (32°F to 104°F) operating temperature which is suitable for the following heat sink dimension.

ECMA-__ 04 / 06 / 08 : 250 mm x 250 mm x 6 mm

ECMA-__ 10 : 300 mm x 300 mm x 12 mm

ECMA-__ 13 : 400 mm x 400 mm x 20 mm

ECMA-__ 18 : 550 mm x 550 mm x 30 mm

ECMA-__ 22 : 650 mm x 650 mm x 35mm

Material: Aluminum – F40, F60, F80, F100, F130, F180, F220

*2. The built-in brake of the servo motor is for remaining the item in stop status. Do not use it to decelerate or as the dynamic brake.

Low Inertia Series

ECMA Series	CΔ10		CΔ13
	10	20	30
Rated power (kW)	1.0	2.0	3.0
Rated torque (N-m) *1	3.18	6.37	9.55
Max. torque (N-m)	9.54	19.11	28.65
Rated speed (r/min)	3000		
Max. speed (r/min)	5000		4500
Rated current (Arms)	7.30	12.05	17.2
Max. instantaneous current (Arms)	21.9	36.15	47.5
Power rating (kW/s)	38.1	90.6	71.8
Rotor inertia ($\times 10^{-4}$ kg.m ²)	2.65	4.45	12.7
Mechanical constant (ms)	0.74	0.61	1.11
Torque constant-KT (N-m/A)	0.44	0.53	0.557
Voltage constant-KE (mV/(r/min))	16.8	19.2	20.98
Armature resistance (Ohm)	0.20	0.13	0.0976
Armature inductance (mH)	1.81	1.50	1.21
Electric constant (ms)	9.30	11.4	12.4
Insulation class	Class A (UL), Class B (CE)		
Insulation resistance	> 100 MΩ, DC 500V		
Insulation strength	1.8k V _{AC} , 1 sec		
Weight (kg) (without brake)	4.3	6.2	7.8
Weight (kg) (with brake)	4.7	7.2	9.2
Radial max. loading (N)	490	490	490
Axial max. loading (N)	98	98	98
Power rating (kW/s) (with brake)	30.4	82.0	65.1
Rotor inertia ($\times 10^{-4}$ kg.m ²) (with brake)	3.33	4.95	14.0
Mechanical constant (ms) (with brake)	0.93	0.66	1.22
Brake holding torque [Nt-m (min)] *2	8.0	8.0	10.0
Brake operating voltage	24V _{DC} \pm 10%		
Brake power consumption (at 20°C) [W]	19.4	19.4	21.5
Brake release time [ms (Max)]	20	20	50
Brake pull-in time [ms (Max)]	100	100	110
Vibration grade (μ m)	15		

ECMA Series	CΔ10		CΔ13
	10	20	30
Operating temperature (°C)	0°C to 40°C (32°F to 104°F)		
Storage temperature (°C)	-10°C to 80°C (14°F to 176°F)		
Operating humidity	20% to 90% RH (non-condensing)		
Storage humidity	20% to 90% RH (non-condensing)		
Vibration capacity	2.5 G		
IP Rating	IP65 (use the waterproof connector and shaft seal installation (or oil seal model))		
Approvals			

Note:

*1. The rated torque is the continuous permissible torque between 0 to 40°C (32°F to 104°F) operating temperature which is suitable for the following heat sink dimension.

ECMA-__ 04 / 06 / 08 : 250 mm x 250 mm x 6 mm

ECMA-__ 10 : 300 mm x 300 mm x 12 mm

ECMA-__ 13 : 400 mm x 400 mm x 20 mm

ECMA-__ 18 : 550 mm x 550 mm x 30 mm

ECMA-__ 22 : 650 mm x 650 mm x 35 mm

Material: Aluminum – F40, F60, F80, F100, F130, F180, F220

*2. The built-in brake of the servo motor is for remaining the item in stop status. Do not use it to decelerate or as the dynamic brake.

Medium / High Inertia Series

ECMA Series	E△13				E△18			G△13		
	05	10	15	20	20	30	35	03	06	09
Rated power (kW)	0.5	1.0	1.5	2.0	2.0	3.0	3.5	0.3	0.6	0.9
Rated torque (N-m) *1	2.39	4.77	7.16	9.55	9.55	14.32	16.71	2.86	5.73	8.59
Max. torque (N-m)	7.16	14.3	21.48	28.65	28.65	42.97	50.13	8.59	17.19	21.48
Rated speed (r/min)	2000							1000		
Max. speed (r/min)	3000							2000		
Rated current (Arms)	2.9	5.6	8.3	11.01	11.22	16.1	19.2	2.5	4.8	7.5
Max. instantaneous current (Arms)	8.7	16.8	24.9	33.03	33.66	48.3	57.6	7.5	14.4	22.5
Power rating (kW/s)	7.0	27.1	45.9	62.5	26.3	37.3	50.8	10.0	39.0	66.0
Rotor inertia ($\times 10^{-4}\text{kg}\cdot\text{m}^2$)	8.17	8.41	11.18	14.59	34.68	54.95	54.95	8.17	8.41	11.18
Mechanical constant (ms)	1.91	1.51	1.10	0.96	1.62	1.06	1.08	1.84	1.40	1.06
Torque constant-KT (N-m/A)	0.83	0.85	0.87	0.87	0.85	0.89	0.87	1.15	1.19	1.15
Voltage constant-KE (mV/(r/min))	30.9	31.9	31.8	31.8	31.4	32.0	32.0	42.5	43.8	41.6
Armature resistance (Ohm)	0.57	0.47	0.26	0.174	0.119	0.052	0.052	1.06	0.82	0.43
Armature inductance (mH)	7.39	5.99	4.01	2.76	2.84	1.38	1.38	14.29	11.12	6.97
Electric constant (ms)	12.96	12.88	15.31	15.86	23.87	26.39	26.39	13.50	13.50	16.06
Insulation class	Class A (UL), Class B (CE)									
Insulation resistance	> 100 MΩ, DC 500V									
Insulation strength	1.8k V _{AC} , 1 sec									
Weight (kg) (without brake)	6.8	7.0	7.5	7.8	13.5	18.5	18.5	6.8	7.0	7.5
Weight (kg) (with brake)	8.2	8.4	8.9	9.2	17.5	22.5	22.5	8.2	8.4	8.9
Radial max. loading (N)	490	490	490	490	1176	1470	490	490	490	490
Axial max. loading (N)	98	98	98	98	490	490	98	98	98	98
Power rating (kW/s) (with brake)	6.4	24.9	43.1	57.4	24.1	35.9	48.9	9.2	35.9	62.1
Rotor inertia ($\times 10^{-4}\text{kg}\cdot\text{m}^2$) (with brake)	8.94	9.14	11.90	15.88	37.86	57.06	57.06	8.94	9.14	11.9
Mechanical constant (ms) (with brake)	2.07	1.64	1.19	1.05	1.77	1.10	1.12	2.0	1.51	1.13
Brake holding torque [Nt-m (min)] *2	10.0	10.0	10.0	10.0	25.0	25.0	25.0	10.0	10.0	10.0
Brake operating voltage	24V _{DC} ± 10%									
Brake power consumption (at 20°C) [W]	21.5	21.5	21.5	21.5	31	31	31	21.5	21.5	21.5

ECMA Series	EΔ13				EΔ18			GΔ13		
	05	10	15	20	20	30	35	03	06	09
Brake release time [ms (Max)]	50	50	50	50	30	30	30	50	50	50
Brake pull-in time [ms (Max)]	110	110	110	110	120	120	120	110	110	110
Vibration grade (μm)	15									
Operating temperature (°C)	0°C to 40°C (32°F to 104°F)									
Storage temperature (°C)	-10°C to 80°C (14°F to 176°F)									
Operating humidity	20% to 90% RH (non-condensing)									
Storage humidity	20% to 90% RH (non-condensing)									
Vibration capacity	2.5 G									
IP Rating	IP65 (use the waterproof connector and shaft seal installation (or oil seal) model)									
Approvals										

Note:

*1. The rated torque is the continuous permissible torque between 0 to 40°C (32°F to 104°F) operating temperature which is suitable for the following heat sink dimension.

ECMA-__ 04 / 06 / 08 : 250 mm x 250 mm x 6 mm

ECMA-__ 10 : 300 mm x 300 mm x 12 mm

ECMA-__ 13 : 400 mm x 400 mm x 20 mm

ECMA-__ 18 : 550 mm x 550 mm x 30 mm

ECMA-__ 22 : 650 mm x 650 mm x 35 mm

Material: Aluminum – F40, F60, F80, F100, F130, F180, F220

*2. The built-in brake of the servo motor is for remaining the item in stop status. Do not use it to decelerate or as the dynamic brake.

Medium-High / High Inertia Series

ECMA Series	FΔ13				FΔ18				F122	
	05	08	13	18	30	45	55	75	1B	1F
Rated power (kW)	0.5	0.85	1.3	1.8	3.0	4.5	5.5	7.5	11	15
Rated torque (N-m) *1	3.18	5.41	8.34	11.48	19.10	28.65	35.01	47.74	70	95.4
Max. torque (N-m)	8.92	13.8	23.3	28.7	57.29	71.62	87.53	119.36	175	224.0
Rated speed (r/min)	1500									
Max. speed (r/min)	3000								2000	
Rated current (Arms)	3.9	7.1	12.6	13.0	19.4	32.5	40.0	47.5	51.8	67.0
Max. instantaneous current (Arms)	12.1	19.4	38.6	36.0	58.2	81.3	100.0	118.8	129.5	162.0
Power rating (kW/s)	9.8	21.52	34.78	52.93	66.4	105.5	122.9	159.7	144.9	201.8
Rotor inertia ($\times 10^{-4}$ kg.m ²)	10.3	13.6	20.0	24.9	54.95	77.75	99.78	142.7	338	451
Mechanical constant (ms)	2.8	2.43	1.62	1.7	1.28	0.92	0.96	0.63	1.38	1.23
Torque constant-KT (N-m/A)	0.82	0.76	0.66	0.88	0.98	0.88	0.88	1.01	1.37	1.42
Voltage constant-KE (mV/(r/min))	29.5	29.2	24.2	32.2	35.0	32.0	31.0	35.5	49.0	50.0
Motor resistance (Ohm)	0.624	0.38	0.124	0.185	0.077	0.032	0.025	0.015	0.026	0.0184
Motor inductance (mH)	7.0	4.77	1.7	2.6	1.27	0.89	0.60	0.40	0.65	0.48
Electric constant (ms)	11.22	12.55	13.71	14.05	16.5	27.8	24.0	26.7	24.79	26.09
Insulation class	Class A (UL), Class B (CE)									
Insulation resistance	> 100 MΩ, DC 500V									
Insulation strength	1.8k V _{AC} , 1 sec									
Weight (kg) (without brake)	6.3	8.6	9.4	10.5	18.5	23.5	30.5	40.5	56.4	75.0
Weight (kg) (with brake)	7.7	10.0	10.8	11.9	22.5	29.0	36.0	46.0	68.4	87.0
Radial max. loading (N)	490	490	490	490	1470	1470	1764	1764	3300	3300
Axial max. loading (N)	98	98	98	98	490	490	588	588	1100	1100
Power rating (kW/s) (with brake)	8.8	19.78	32.66	50.3	63.9	101.8	119.4	156.6	141.4	197.1
Rotor inertia ($\times 10^{-4}$ kg.m ²) (with brake)	11.5	14.8	21.3	26.2	57.06	80.65	102.70	145.55	346.5	461.8
Mechanical constant (ms) (with brake)	3.12	2.65	1.73	1.79	1.33	0.96	0.99	0.64	1.41	1.25
Brake holding torque [Nt-m (min)] *2	10.0	10.0	10.0	10.0	25.0	55.0	55.0	55.0	115	115
Brake operating voltage	24V _{DC} ± 10%									
Brake power consumption (at 20°C) [W]	21.5	21.5	21.5	21.5	31	31	31	31	32	32

ECMA Series	FΔ13				FΔ18				F122	
	05	08	13	18	30	45	55	75	1B	1F
Brake release time [ms (Max)]	50	50	50	50	30	50	50	50	100	100
Brake pull-in time [ms (Max)]	110	110	110	110	120	150	150	150	500	500
Vibration grade (μm)	15									
Operating temperature (°C)	0°C to 40°C (32°F to 104°F)									
Storage temperature (°C)	-10°C to 80°C (14°F to 176°F)									
Operating humidity	20% to 90% RH (non-condensing)									
Storage humidity	20% to 90% RH (non-condensing)									
Vibration capacity	2.5 G									
IP Rating	IP65 (use the waterproof connector and shaft seal installation (or oil seal) model)									
Approvals										

Note:

*1 The rated torque is the continuous permissible torque between 0 to 40°C (32°F to 104°F) operating temperature which is suitable for the following heat sink dimension.

ECMA-__04 / 06 / 08 : 250 mm x 250 mm x 6 mm

ECMA-__10 : 300 mm x 300 mm x 12 mm

ECMA-__13 : 400 mm x 400 mm x 20 mm

ECMA-__18 : 550 mm x 550 mm x 30 mm

ECMA-__22 : 650 mm x 650 mm x 35 mm

Material: Aluminum – F40, F60, F80, F100, F130, F180, F220

*2 The built-in brake of the servo motor is for remaining the item in stop status. Do not use it to decelerate or as the dynamic brake.

3 If desiring to reach the max. torque limit of motor 250%, it is suggested to use the servo drive with higher watt.

High Inertia Series

ECMA	C△06	C△08
	04□H	07□H
Rated power (kW)	0.4	0.75
Rated torque (N-m)*1	1.27	2.39
Max. torque (N-m)	3.82	7.16
Rated speed (r/min)	3000	3000
Max. speed (r/min)	5000	5000
Rated current (Arms)	2.6	5.1
Max. instantaneous current (Arms)	7.8	15.3
Max. power per second (kW/s)	21.7	19.63
Rotor inertia (× 10 ⁻⁴ kg.m ²)	0.743	2.91
Mechanical constant (ms)	1.42	1.6
Torque constant – KT (N-m/A)	0.49	0.47
Voltage constant – KE (mV/(r/min))	17.4	17.2
Armature resistance (Ohm)	1.55	0.42
Armature inductance (mH)	6.71	3.53
Electric constant (ms)	4.3	8.36
Insulation class	Class A (UL), Class B (CE)	
Insulation resistance	> 100MΩ, DC 500V	
Insulation strength	1.8k V _{AC} , 1 sec	
Weight – without brake (kg)	1.8	3.4
Weight – with brake (kg)	2.2	3.9
Radial max. loading (N)	196	245
Axial max. loading (N)	68	98
Max. power per second (kW/s) (with brake)	21.48	19.3
Rotor inertia (× 10 ⁻⁴ kg.m ²) (with brake)	0.751	2.96
Mechanical constant (ms) (with brake)	1.43	1.62
Brake holding torque [Nt-m (min)]*2	1.3	2.5
Brake operating voltage	24V _{DC} ± 10%	
Brake power consumption (at 20°C) [W]	7.2	8.4
Brake release time [ms (Max)]	20	40
Brake pull-in time [ms (Max)]	70	70
Vibration grade (μm)	15	
Operating temperature (°C)	0°C to 40°C (32°F to 104°F)	

ECMA	C△06	C△08
	04□H	07□H
Storage temperature (°C)	-10°C to 80°C (14°F to 176°F)	
Operating humidity	20 to 90% RH (non-condensing)	
Storage humidity	20 to 90% RH (non-condensing)	
Vibration capacity	2.5 G	
IP Rating	IP65 (use the waterproof connector and shaft seal installation (or oil seal)	
Approvals		

Note:

*1 The rated torque is the continuous permissible torque between 0 to 40°C (32°F to 104°F) operating temperature which is suitable for the following heat sink dimension.

ECMA-__ 04 / 06 / 08 : 250 mm x 250 mm x 6 mm

ECMA-__ 10 : 300 mm x 300 mm x 12 mm

ECMA-__ 13 : 400 mm x 400 mm x 20 mm

ECMA-__ 18 : 550 mm x 550 mm x 30 mm

ECMA-__ 22 : 650 mm x 650 mm x 35 mm

Material: Aluminum – F40, F60, F80, F100, F130, F180, F220

*2 The built-in brake of the servo motor is for remaining the item in stop status. Do not use it to decelerate or as the dynamic brake.

3 If desiring to reach the max. torque limit of motor 250%, it is suggested to use the servo drive with higher watt.

11.2.2 ECMA 400V Series

Low Inertia Series

ECMA Series	J△06	J△08	J△09		J△10		J△13
	04	07	07	10	10	20	30
Rated power (kW)	0.4	0.75	0.75	1	1.0	2.0	3.0
Rated torque (N-m) ^{*1}	1.27	2.39	2.39	3.18	3.18	6.37	9.55
Max. torque (N-m)	3.82	7.16	7.14	8.78	9.54	19.1	28.65
Rated speed (r/min)	3000		3000		3000		3000
Maximum speed (r/min)	5000		3000		5000		4500
Rated current (Arms)	1.62	3.07	2.16	2.4	4.15	7.09	9.8
Max. instantaneous current (Arms)	4.85	9.5	6.37	7.17	12.46	21.28	29.99
Power rating (kW/s)	58.2	50.4	29.6	38.6	38.2	91.2	71.8
Rotor inertia (× 10 ⁻⁴ kg.m ²)	0.277	1.13	1.93	2.62	2.65	4.45	12.7
Mechanical constant (ms)	0.47	0.66	1.56	1.06	0.77	0.58	0.99
Torque constant-KT (N-m/A)	0.79	0.78	1.12	1.29	0.77	0.9	0.97
Voltage constant-KE (mV/(r/min))	30.6	28.24	42	50.9	29.0	34.4	37.3
Armature resistance (Ohm)	3.95	1.22	3.62	2.58	0.617	0.388	0.269
Armature inductance (mH)	21.3	10.68	21.2	15.28	6.03	4.62	3.55
Electric constant (ms)	5.39	8.75	5.85	5.93	9.77	11.9	13.2
Insulation class	Class A (UL), Class B (CE)						
Insulation resistance	> 100 MΩ, DC 500V						
Insulation strength	2.3k V _{AC} , 1 sec						
Weight (kg) (without brake)	1.6	3.0	2.9	3.8	4.3	6.2	7.8
Weight (kg) (with brake)	2.0	3.8	-	-	4.7	7.2	9.2
Radial max. loading (N)	196	245	245	245	490	490	490
Axial max. loading (N)	68	98	98	98	98	98	98
Power rating (kW/s) (with brake)	53.8	48.4	29.3	37.9	30.4	82	65.1
Rotor inertia (× 10 ⁻⁴ kg.m ²) (with brake)	0.3	1.18	1.95	2.67	3.33	4.95	14.0
Mechanical constant (ms) (with brake)	0.52	0.65	1.57	1.08	0.96	0.65	1.09
Brake holding torque [Nt-m (min)] ^{*2}	1.3	2.5	2.5	2.5	8.0	8.0	10.0
Brake operating voltage	24V _{DC} ± 10%						
Brake power consumption (at 20°C) [W]	7.2	8.4	8.4	8.4	19.4	19.4	21.5

ECMA Series	J△06	J△08	J△09		J△10		J△13
	04	07	07	10	10	20	30
Brake release time [ms (Max)]	20	40	40	40	20	20	50
Brake pull-in time [ms (Max)]	70	70	70	70	100	100	110
Vibration grade (μm)	15						
Operating temperature (°C)	0°C to 40°C (32°F to 104°F)						
Storage temperature (°C)	-10°C to 80°C (14°F to 176°F)						
Operating humidity	20% to 90% RH (non-condensing)						
Storage humidity	20% to 90% RH (non-condensing)						
Vibration capacity	2.5 G						
IP Rating	IP65 (use the waterproof connector and shaft seal installation (or oil seal) model)						
Approvals							

Note:

*1 The rated torque is the continuous permissible torque between 0 to 40°C (32°F to 104°F) operating temperature which is suitable for the following heat sink dimension.

ECMA-__ 08 : 250 mm x 250 mm x 6 mm

ECMA-__ 13 : 400 mm x 400 mm x 20 mm

ECMA-__ 18 : 550 mm x 550 mm x 30 mm

Material: Aluminum – F80, F130, F180

*2 The built-in brake of the servo motor is for remaining the item in stop status. Do not use it to decelerate or as the dynamic brake.

Medium Inertia Series

ECMA Series	K Δ 13				K Δ 18
	05	10	15	20	20
Rated power (kW)	0.5	1.0	1.5	2.0	2.0
Rated torque (N-m) ^{*1}	2.39	4.77	7.16	9.55	9.55
Max. torque (N-m)	7.16	14.32	21.48	28.65	28.65
Rated speed (r/min)	2000				
Maximum speed (r/min)	3000				
Rated current (Arms)	1.7	3.52	5.02	6.66	6.6
Max. instantaneous current (Arms)	5.2	10.56	15.06	19.98	19.88
Power rating (kW/s)	6.99	27.1	45.9	62.5	26.3
Rotor inertia ($\times 10^{-4}$ kg.m ²)	8.17	8.41	11.18	14.59	34.68
Mechanical constant (ms)	2.08	1.80	1.24	1.04	1.74
Torque constant-KT (N-m/A)	1.41	1.35	1.43	1.43	1.45
Voltage constant-KE (mV/(r/min))	51.5	53.2	55.0	55.0	54.0
Armature resistance (Ohm)	1.76	1.47	0.83	0.57	0.376
Armature inductance (mH)	22.4	17.79	11.67	8.29	7.87
Electric constant (ms)	12.73	12.04	14.04	14.39	20.9
Insulation class	Class A (UL), Class B (CE)				
Insulation resistance	> 100 M Ω , DC 500V				
Insulation strength	2.3k V _{AC} , 1 sec				
Weight (kg) (without brake)	6.8	7.0	7.5	7.8	13.5
Weight (kg) (with brake)	8.2	8.4	8.9	9.2	17.5
Radial max. loading (N)	490	490	490	490	1176
Axial max. loading (N)	98	98	98	98	490
Power rating (kW/s) (with brake)	6.39	24.9	43.1	59.7	24.1
Rotor inertia ($\times 10^{-4}$ kg.m ²) (with brake)	8.94	9.14	11.90	15.88	37.86
Mechanical constant (ms) (with brake)	2.28	1.96	1.32	1.13	1.9
Brake holding torque [Nt-m (min)] ^{*2}	10.0	10.0	10.0	10.0	25.0
Brake operating voltage	24V _{DC} \pm 10%				
Brake power consumption (at 20°C) [W]	21.5	21.5	21.5	21.5	31
Brake release time [ms (Max)]	50	50	50	50	30

ECMA Series	K△13				K△18
	05	10	15	20	20
Brake pull-in time [ms (Max)]	110	110	110	110	120
Vibration grade (μm)	15				
Operating temperature (°C)	0°C to 40°C (32°F to 104°F)				
Storage temperature (°C)	-10°C to 80°C (14°F to 176°F)				
Operating humidity	20% to 90% RH (non-condensing)				
Storage humidity	20% to 90% RH (non-condensing)				
Vibration capacity	2.5 G				
IP Rating	IP65 (use the waterproof connector and shaft seal installation (or oil seal) model)				
Approvals					

Note:

*1 The rated torque is the continuous permissible torque between 0 to 40°C (32°F to 104°F) operating temperature which is suitable for the following heat sink dimension.

ECMA-__ 08: 250 mm x 250 mm x 6 mm

ECMA-__ 13: 400 mm x 400 mm x 20 mm

ECMA-__ 18: 550 mm x 550 mm x 30 mm

Material: Aluminum – F80, F130, F180

*2 The built-in brake of the servo motor is for remaining the item in stop status. Do not use it to decelerate or as the dynamic brake.

Medium-High Inertia Series

ECMA Series	L Δ 18				L122	
	30	45	55	75	1B	1F
Rated power (kW)	3.0	4.5	5.5	7.5	11	15
Rated torque (N-m) *1	19.10	28.65	35.0	47.74	70	95.4
Max. torque (N-m)	57.29	71.62	87.53	119.36	175	224
Rated speed (r/min)	1500				1500	
Max. speed (r/min)	3000				2000	
Rated current (Arms)	11.53	20.8	22.37	27.3	27.2	41.6
Max. instantaneous current (Arms)	34.6	52.0	56.0	68.3	68	100
Power rating (kW/s)	66.4	105.5	122.9	159.7	145	201.8
Rotor inertia ($\times 10^{-4}$ kg.m ²)	54.95	77.75	99.78	142.7	338	451
Mechanical constant (ms)	1.11	0.94	0.88	0.77	1.42	1.34
Torque constant-KT (N-m/A)	1.66	1.38	1.56	1.75	2.57	2.29
Voltage constant-KE (mV/(r/min))	64.4	53.0	58.9	66.4	96	83.9
Motor resistance (Ohm)	0.21	0.09	0.07	0.06	0.0994	0.0545
Motor inductance (mH)	4.94	2.36	2.2	1.7	2.51	1.43
Electric constant (ms)	23.97	28.07	27.6	28.29	25.25	26.26
Insulation class	Class A (UL), Class B (CE)					
Insulation resistance	> 100 M Ω , DC 500V					
Insulation strength	2.3k V _{AC} , 1 sec					
Weight (kg) (without brake)	18.5	23.5	30.5	40.5	56.4	75
Weight (kg) (with brake)	22.5	29	36	46	68.4	87
Radial max. loading (N)	1470	1470	1764	1764	3300	3300
Axial max. loading (N)	490	490	588	588	1100	1100
Power rating (kW/s) (with brake)	63.9	101.8	119.4	156.6	141.4	197.1
Rotor inertia ($\times 10^{-4}$ kg.m ²) (with brake)	57.06	80.65	102.70	145.5	346.5	461.8
Mechanical constant (ms) (with brake)	1.16	0.95	0.91	0.79	1.46	1.37
Brake holding torque [Nt-m (min)]	25.0	55.0	55.0	55.0	115	115
Brake operating voltage	24V _{DC} \pm 10%					
Brake power consumption (at 20°C) [W]	31	31	31	31	32	32
Brake release time [ms (Max)]	30	50	50	50	100	100
Brake pull-in time [ms (Max)]	120	150	150	150	500	500

ECMA Series	L Δ 18				L122	
	30	45	55	75	1B	1F
Vibration grade (μm)	15					
Operating temperature ($^{\circ}\text{C}$)	0 $^{\circ}\text{C}$ to 40 $^{\circ}\text{C}$ (32 $^{\circ}\text{F}$ to 104 $^{\circ}\text{F}$)					
Storage temperature ($^{\circ}\text{C}$)	-10 $^{\circ}\text{C}$ to 80 $^{\circ}\text{C}$ (14 $^{\circ}\text{F}$ to 176 $^{\circ}\text{F}$)					
Operating humidity	20% to 90% RH (non-condensing)					
Storage humidity	20% to 90% RH (non-condensing)					
Vibration capacity	2.5 G					
IP Rating	IP65 (use the waterproof connector and shaft seal installation (or oil seal) model)					
Approvals						

Note:

*1 The rated torque is the continuous permissible torque between 0 to 40 $^{\circ}\text{C}$ (32 $^{\circ}\text{F}$ to 104 $^{\circ}\text{F}$) operating temperature which is suitable for the following heat sink dimension.

ECMA-__ 08: 250 mm x 250 mm x 6 mm

ECMA-__ 13: 400 mm x 400 mm x 20 mm

ECMA-__ 18: 550 mm x 550 mm x 30 mm

ECMA-__ 22: 650 mm x 650 mm x 35 mm

Material type: Aluminum – F80, F130, F180, F220

*2 The built-in brake of the servo motor is for remaining the item in stop status. Do not use it to decelerate or as the dynamic brake.

High Inertia Series

ECMA Series	L Δ 13				M Δ 13
	05	08	13	18	09
Rated power (kW)	0.5	0.85	1.3	1.8	0.9
Rated torque (N-m) ^{*1}	3.18	5.39	8.34	11.5	8.59
Max. torque (N-m)	8.92	13.8	23.3	28.7	21.48
Rated speed (r/min)	1500	1500	1500	1500	1000
Max. speed (r/min)	3000	3000	3000	3000	2000
Rated current (Arms)	2.1	3.4	5.02	11.2	4.4
Max. constant current (Arms)	6.1	8.85	15	30.4	13.1
Power rating (kW/s)	7.72	17.0	29.47	50.9	66
Rotor inertia ($\times 10^{-4}$ kg.m ²)	13.1	17.1	23.6	26	11.18
Mechanical constant (ms)	2.3	1.76	1.44	1.45	1.21
Torque constant-KT (N-m/A)	1.5	1.59	1.66	1.03	1.95
Voltage constant-KE (mV/(r/min))	55.5	58.9	61.1	37	71.7
Armature resistance (Ohm)	1.41	0.92	0.59	0.203	1.45
Armature inductance (mH)	20	14.1	9.54	3.09	23.3
Electrical constant (ms)	14.1	15.33	16.17	15.22	16.07
Insulation class	Class A (UL), Class B (CE)				
Insulation resistance	> 100 M Ω , DC 500V				
Insulation strength	2.3k V _{AC} , 1 sec				
Weight (kg) (without brake)	6.8	8.6	10.7	11.2	7.5
Weight (kg) (with brake)	-	10	-	-	8.9
Radial max. loading (N)	490	490	490	490	490
Axial max. loading (N)	98	98	98	98	98
Power rating (kW/s) (with brake)	7.02	14.82	27.82	48.3	62
Rotor inertia ($\times 10^{-4}$ kg.m ²) (with brake)	14.4	19.6	25	27.4	11.9
Mechanical time constant (ms) (with brake)	2.54	2.02	1.52	1.53	1.29
Brake holding torque [Nt-m (min)] ^{*2}	10.0	10.0	10.0	10.0	10.0
Brake operating voltage	24V _{DC} \pm 10%				
Brake power consumption (at 20°C) [W]	21.5	21.5	21.5	21.5	21.5
Brake release time [ms (Max.)]	50	50	50	50	50
Brake pull-in time [ms (Max.)]	110	110	110	110	110
Vibration grade (μ m)	15				
Operating temperature (°C)	0°C to 40°C (32°F to 104°F)				

ECMA Series	L Δ 13				M Δ 13
	05	08	13	18	09
Storage temperature (°C)	-10°C to 80°C (14°F to 176°F)				
Operating humidity	20 to 90% RH (non-condensing)				
Storage humidity	20 to 90% RH (non-condensing)				
Vibration capacity	2.5 G				
IP Rating	IP65 (use the waterproof connector and shaft seal installation (or oil seal) model)				
Approvals					

Note:

*1 The rated torque is the continuous permissible torque between 0 to 40°C (32°F to 104°F) operating temperature which is suitable for the following heat sink dimension.

ECMA-__ 08 : 250 mm x 250 mm x 6 mm

ECMA-__ 13 : 400 mm x 400 mm x 20 mm

ECMA-__ 18 : 550 mm x 550 mm x 30 mm

ECMA-__ 22 : 650 mm x 650 mm x 35 mm

Material type: Aluminum –F80, F130, F180, F220

*2 The built-in brake of the servo motor is for remaining the item in stop status. Do not use it to decelerate or as the dynamic brake.

3 Model of ECMA-L11308 is applying for UL approval.

11.3 Torque Features (T-N Curves)

11.3.1 220V Series

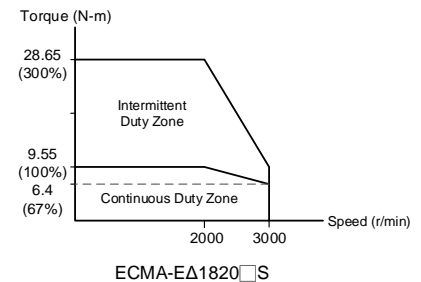
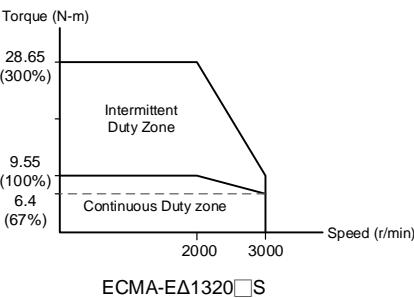
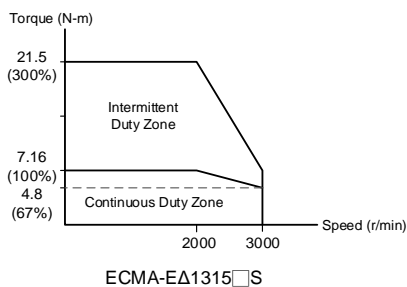
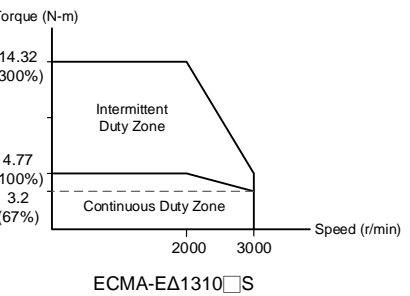
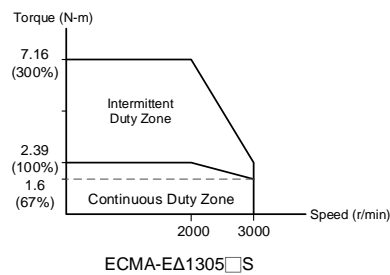
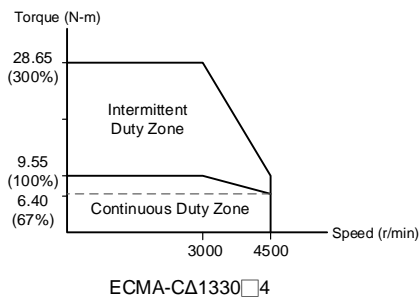
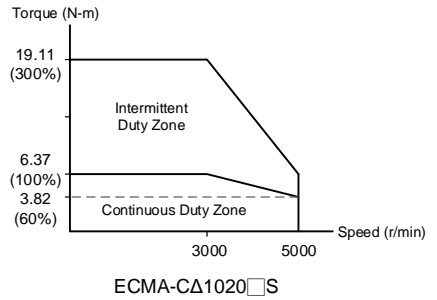
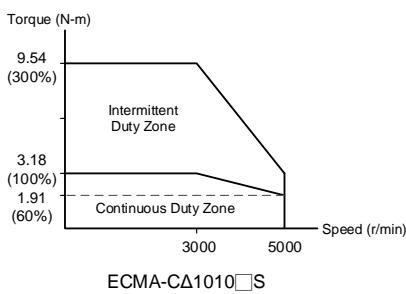
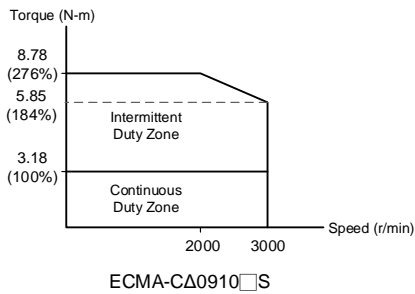
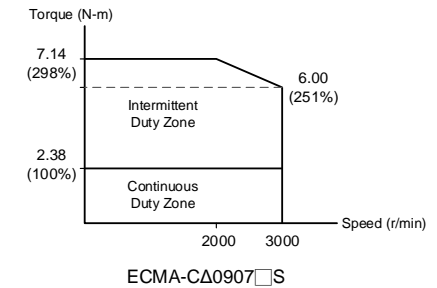
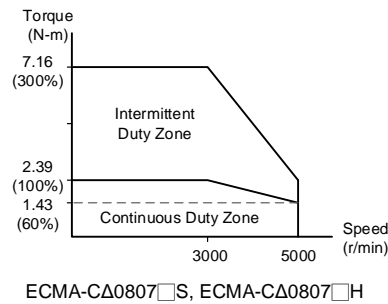
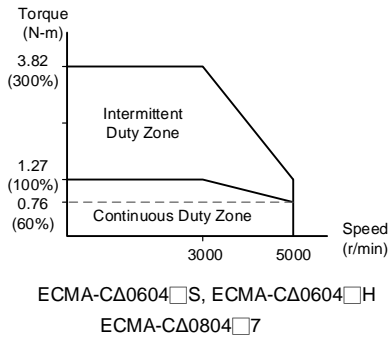
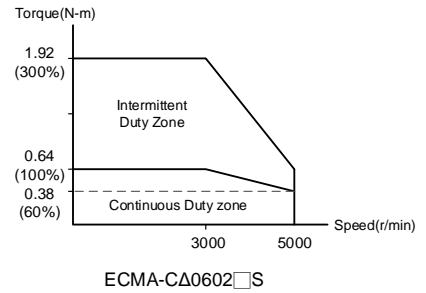
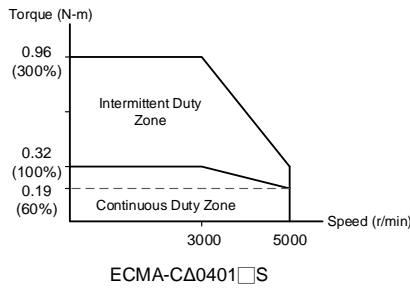
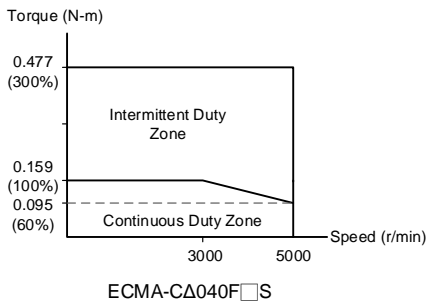

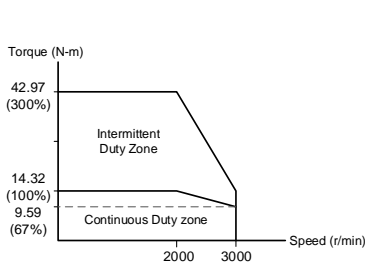

ECMA-EΔ1830□S

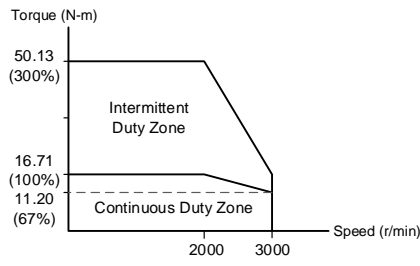

ECMA-EΔ1835□S

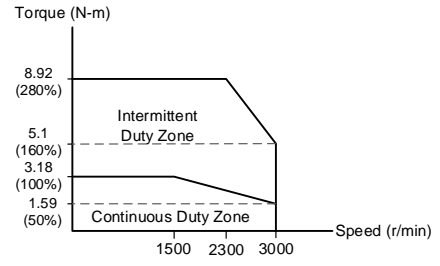

ECMA-FΔ1305□S

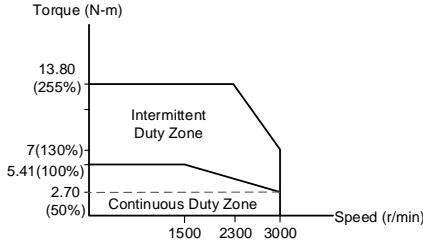

ECMA-FΔ1308□S

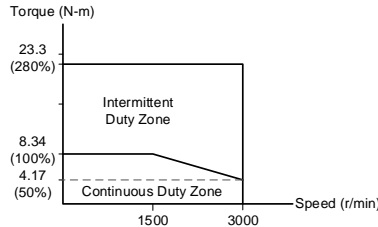

ECMA-FΔ1313□S

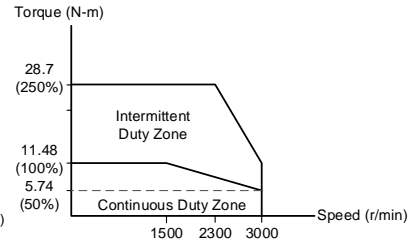

ECMA-FΔ1318□S

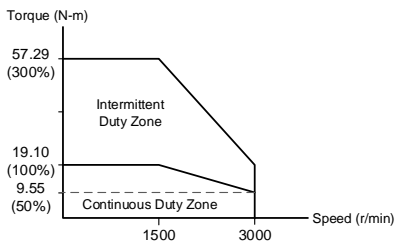

ECMA-FΔ1830□S

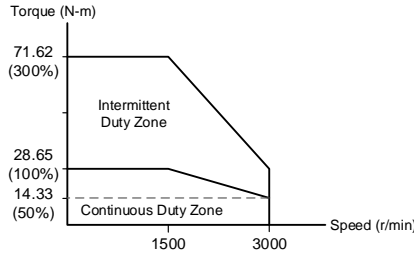

ECMA-FΔ1845□S

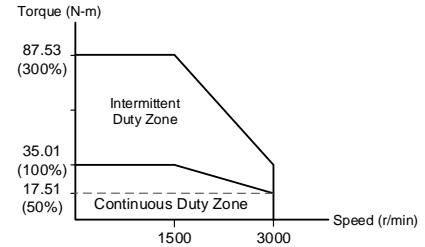

ECMA-FΔ1855□S

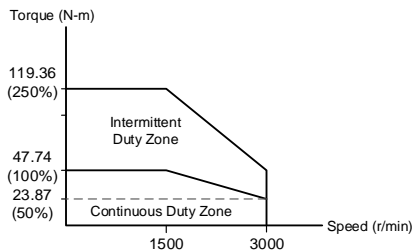

ECMA-FΔ1875□S

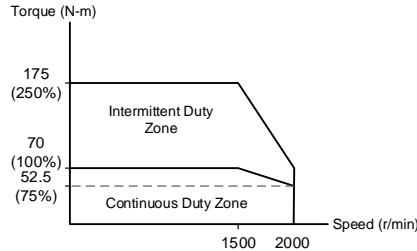

ECMA-F1221B□3

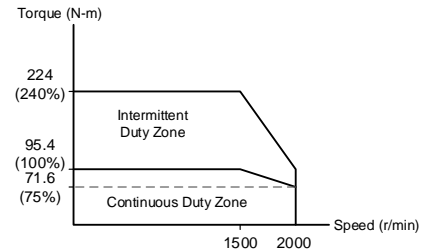

ECMA-F1221F□S

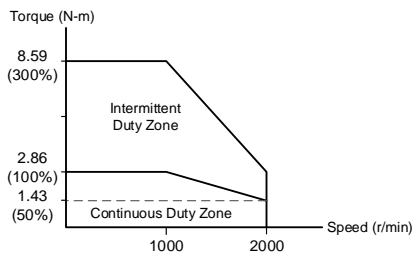

ECMA-GΔ1303□S

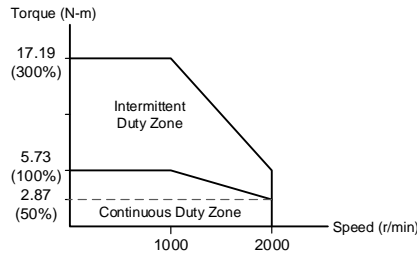

ECMA-GΔ1306□S

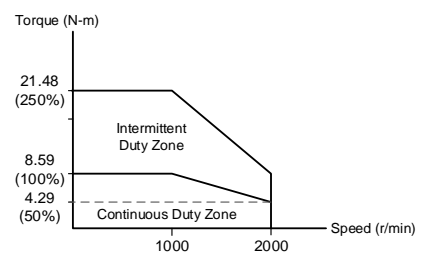

ECMA-GΔ1309□S

11.3.2 400V Series

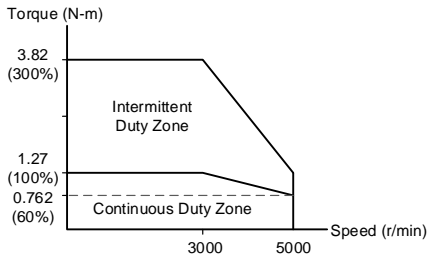

ECMA-JΔ0604 S

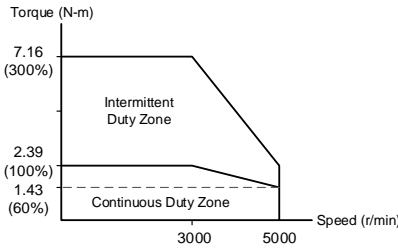

ECMA-JΔ0807 S

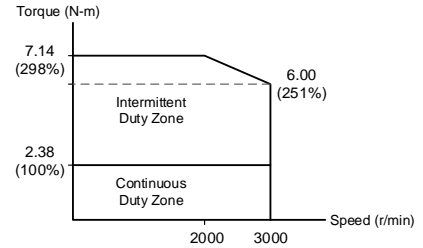

ECMA-JΔ0907 S

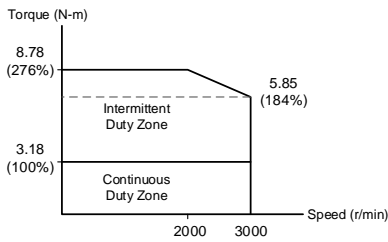

ECMA-JΔ0910 S

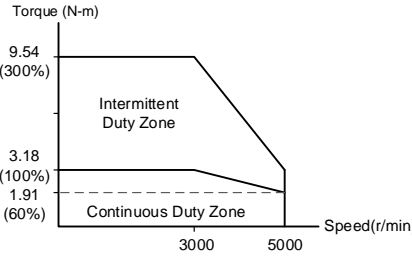

ECMA-JΔ1010 S

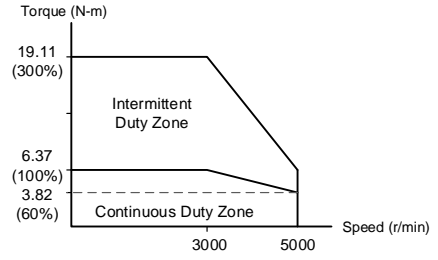

ECMA-JΔ1020 S

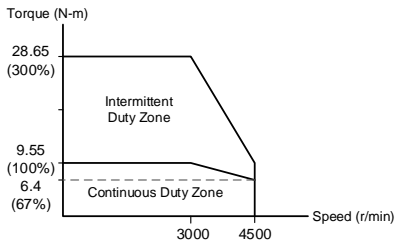

ECMA-JΔ1330 4

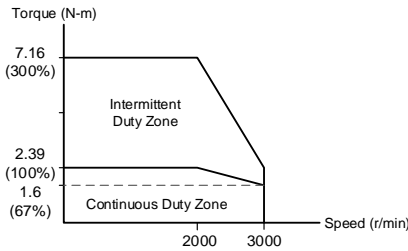

ECMA-KΔ1305 S

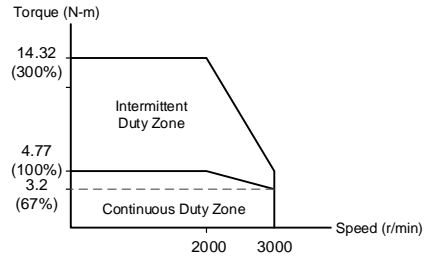

ECMA-KΔ1310 S

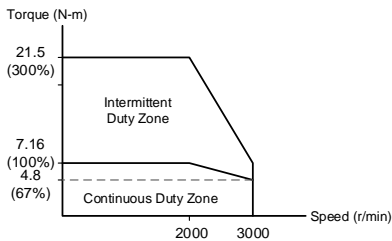

ECMA-KΔ1315 S

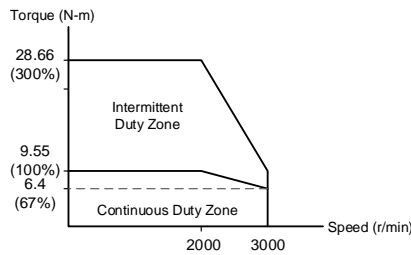

ECMA-KΔ1320 S

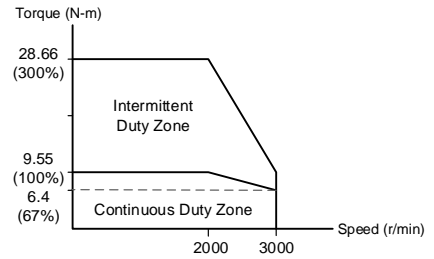

ECMA-KΔ1820 S

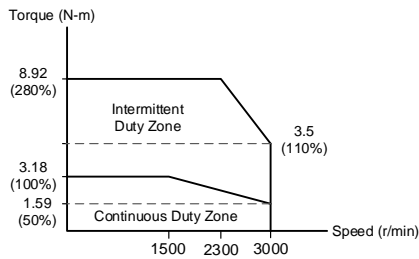

ECMA-LΔ1305 S

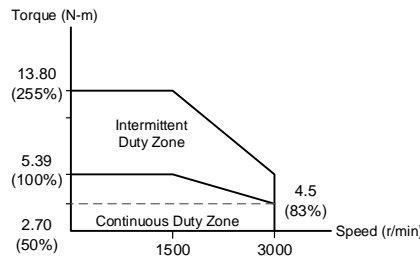

ECMA-LΔ1308 S

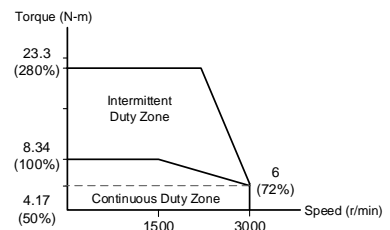

ECMA-LΔ1313 S

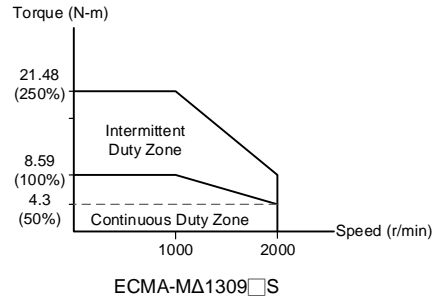
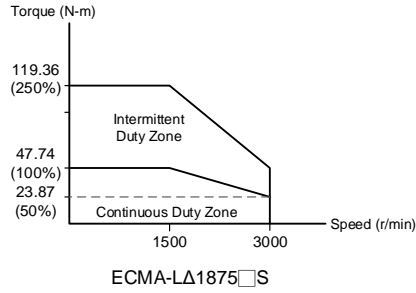
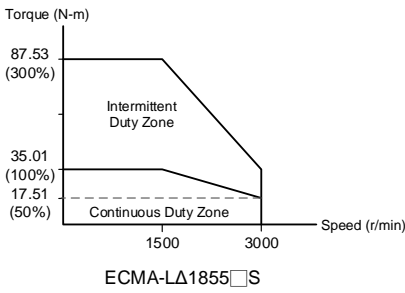
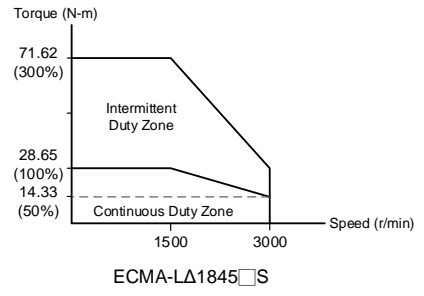
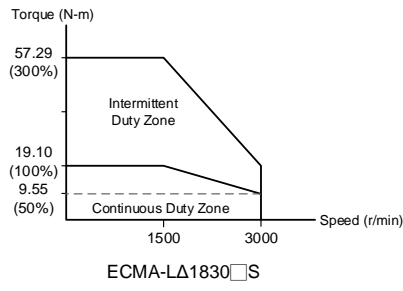
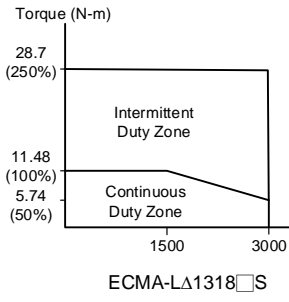

11.4 Overload Features

Definition of overload protection

The overload protection is to prevent the motor from overheating.

Cause of overload

- 1) When the motor operates over the rated torque, the operation time is too long
- 2) The inertia ratio is set too big and the motor accelerates / decelerates too often
- 3) Connection error between the power cable and encoder wiring
- 4) The servo gain setting error causes resonance of the motor
- 5) The motor with brake operates without releasing the brake

The graph of load and operating time

Low Inertia Series (ECMA C1, J1 Series)

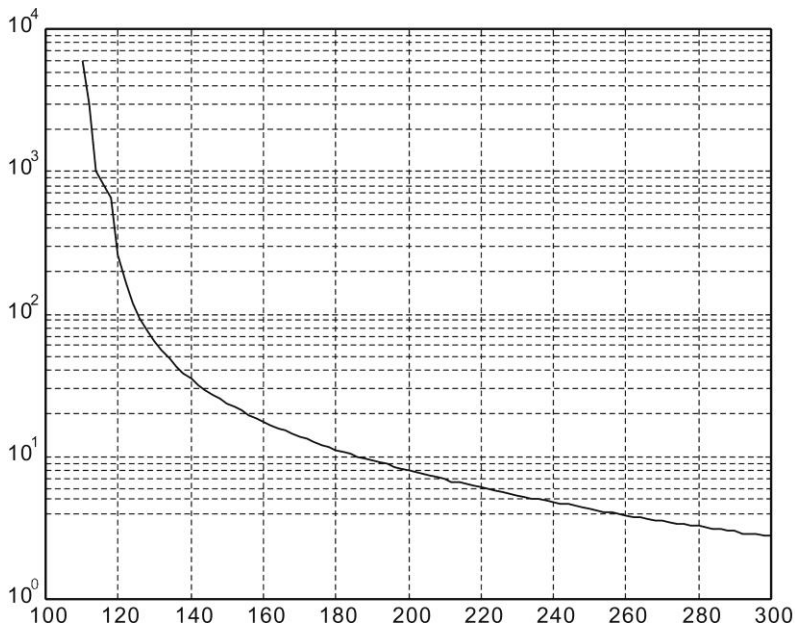

Load	Operating Time
120%	263.8s
140%	35.2s
160%	17.6s
180%	11.2s
200%	8s
220%	6.1s
240%	4.8s
260%	3.9s
280%	3.3s
300%	2.8s

Medium and Medium-High Inertia Series (ECMA E1, F1, K1 and L1 Series)

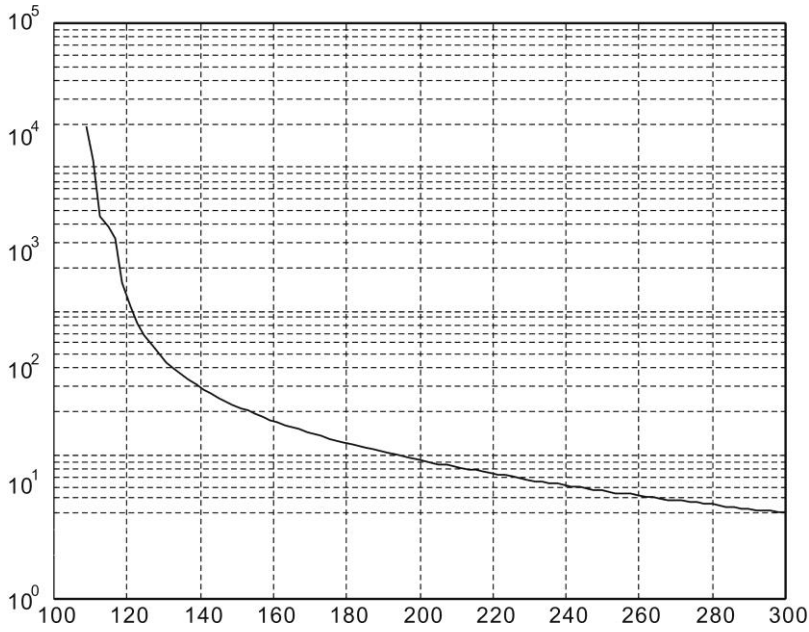

Load	Operating Time
120%	527.6s
140%	70.4s
160%	35.2s
180%	22.4s
200%	16s
220%	12.2s
240%	9.6s
260%	7.8s
280%	6.6s
300%	5.6s

High Inertia Series (ECMA G1 Series)

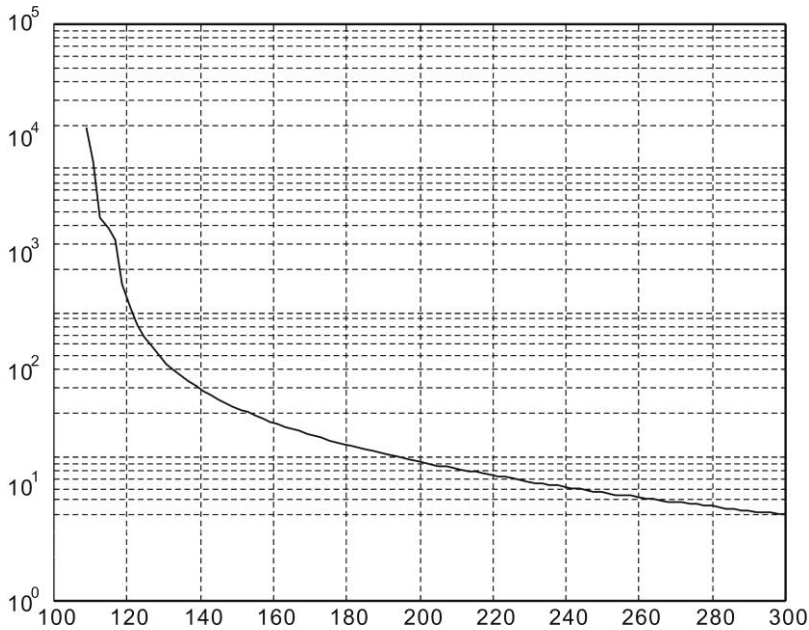

Load	Operating Time
120%	527.6s
140%	70.4s
160%	35.2s
180%	22.4s
200%	16s
220%	12.2s
240%	9.6s
260%	7.8s
280%	6.6s
300%	5.6s

11.5 Dimensions of Servo Drive

11.5.1 220V Series

ASD-A2-0121; ASD-A2-0221; ASD-A2-0421 (100 W ~ 400 W)

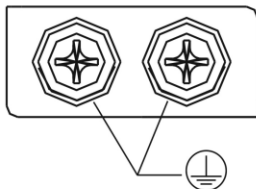
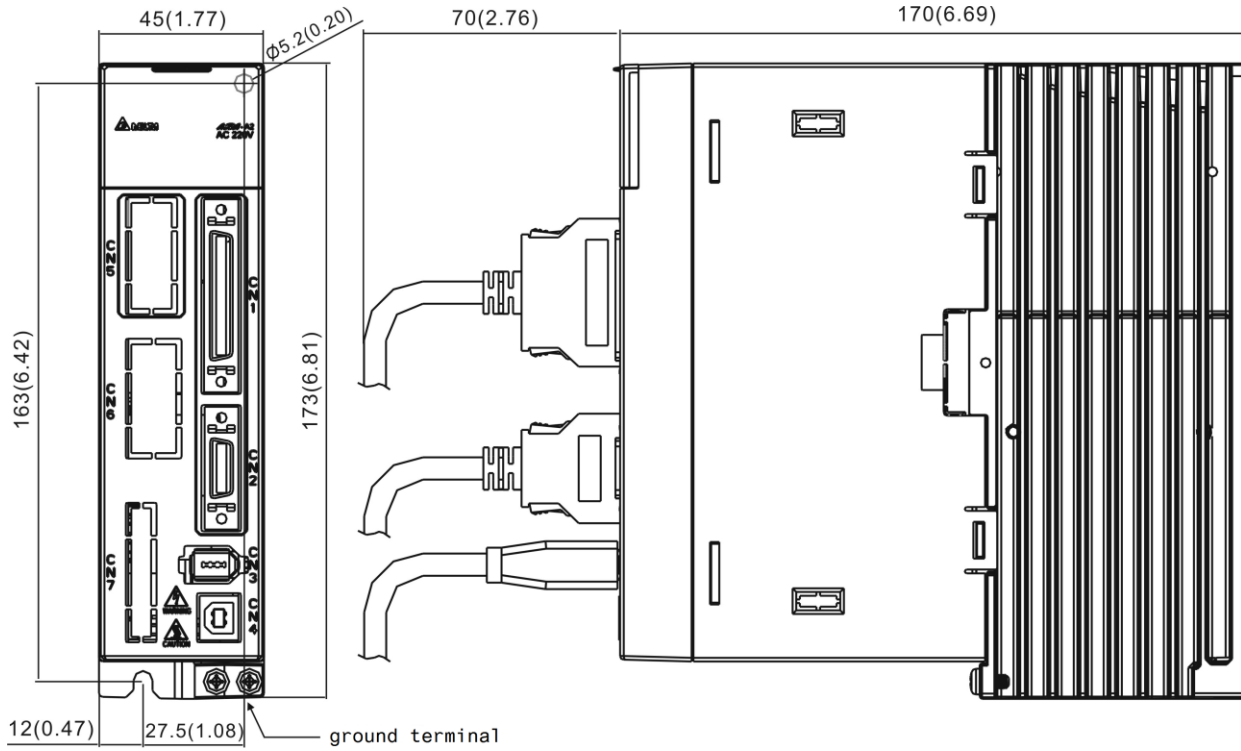

screw: M4 x 0.7
tightening torque: 14 (kgf-cm)

Weight
1.5 (3.3)

Note:

1. Dimensions are in millimeters (inches); weights are in kilograms (kg) and (pounds (lbs)).
2. Dimensions and weights of the servo drive may be revised without prior notice.

ASD-A2-0721; ASD-A2-1021; ASD-A2-1521 (750 W ~ 1.5 kW)

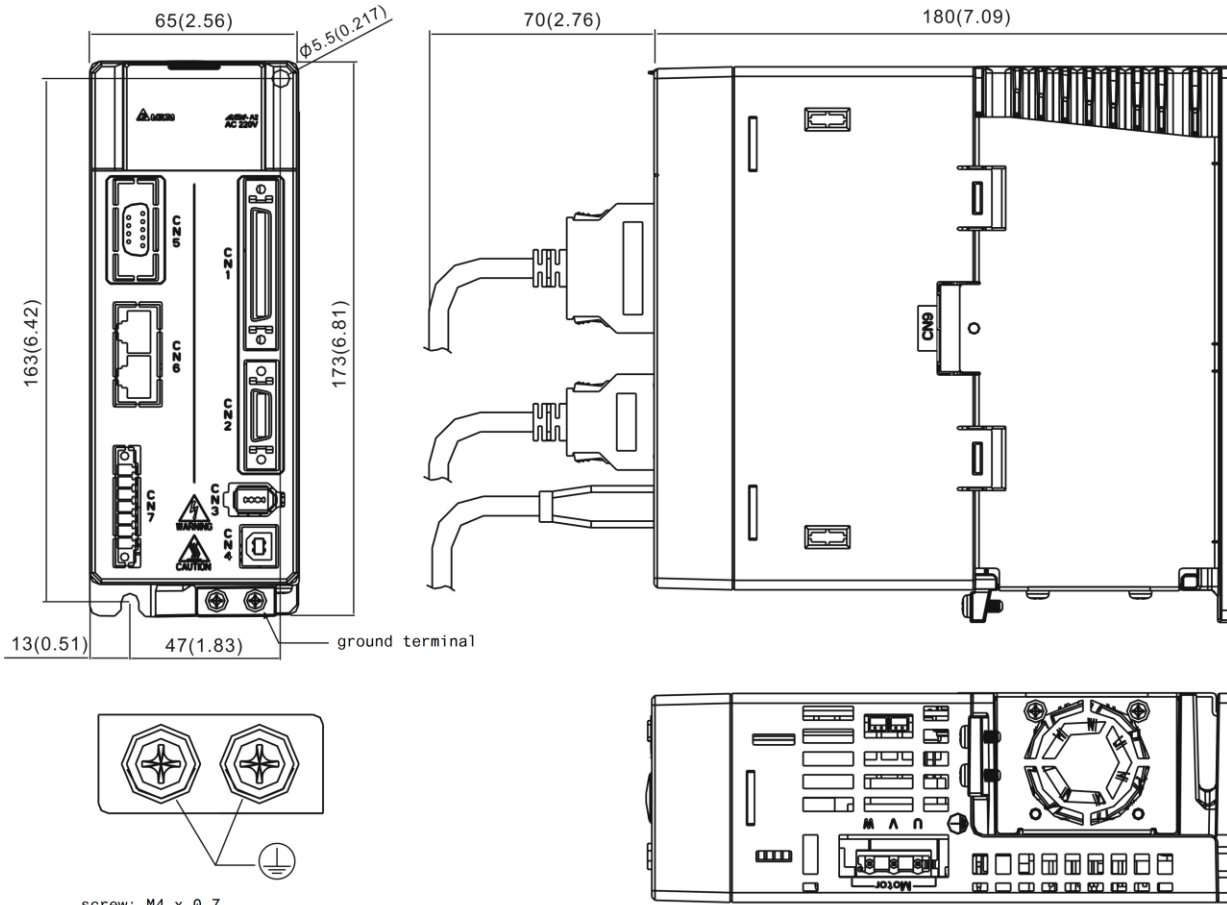

screw: M4 x 0.7
tightening torque: 14 (kgf-cm)

Weight
2.0 (4.4)

- Note:
1. Dimensions are in millimeters (inches); weights are in kilograms (kg) and (pounds (lbs)).
 2. Dimensions and weights of the servo drive may be revised without prior notice.

ASD-A2-2023; ASD-A2-3023 (2 kW ~ 3 kW)

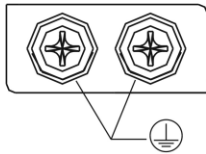
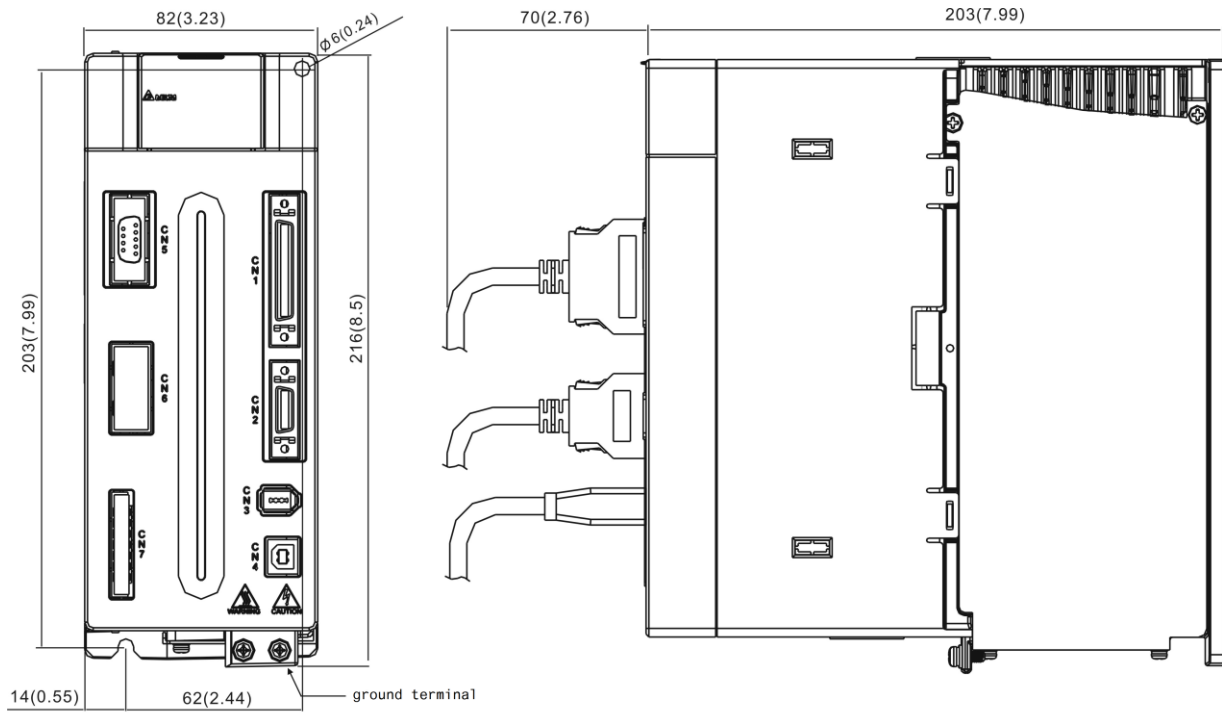

screw: M4 x 0.7
tightening torque: 14 (kgf-cm)

Weight
2.89 (6.36)

Note:

1. Dimensions are in millimeters (inches); weights are in kilograms (kg) and (pounds (lbs)).
2. Dimensions and weights of the servo drive may be revised without prior notice.

ASD-A2-4523 (4.5 kW)

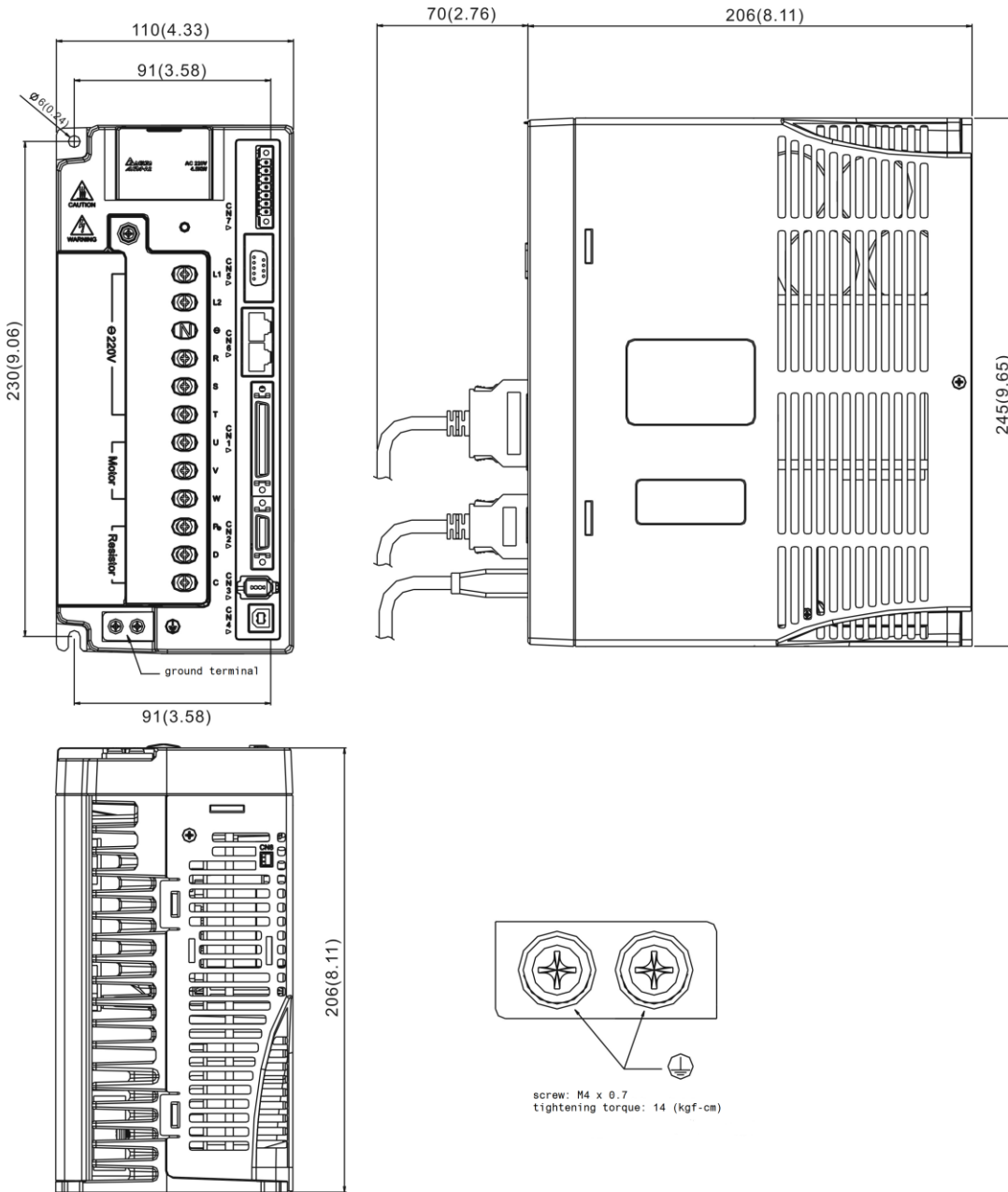

Weight
4.4 (10.0)

Note:

1. Dimensions are in millimeters (inches); weights are in kilograms (kg) and (pounds (lbs)).
2. Dimensions and weights of the servo drive may be revised without prior notice.

ASD-A2-5523 (5.5 kW)

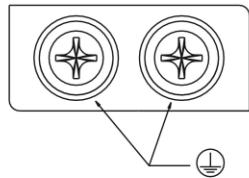
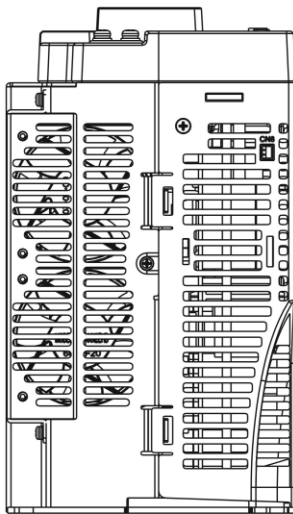
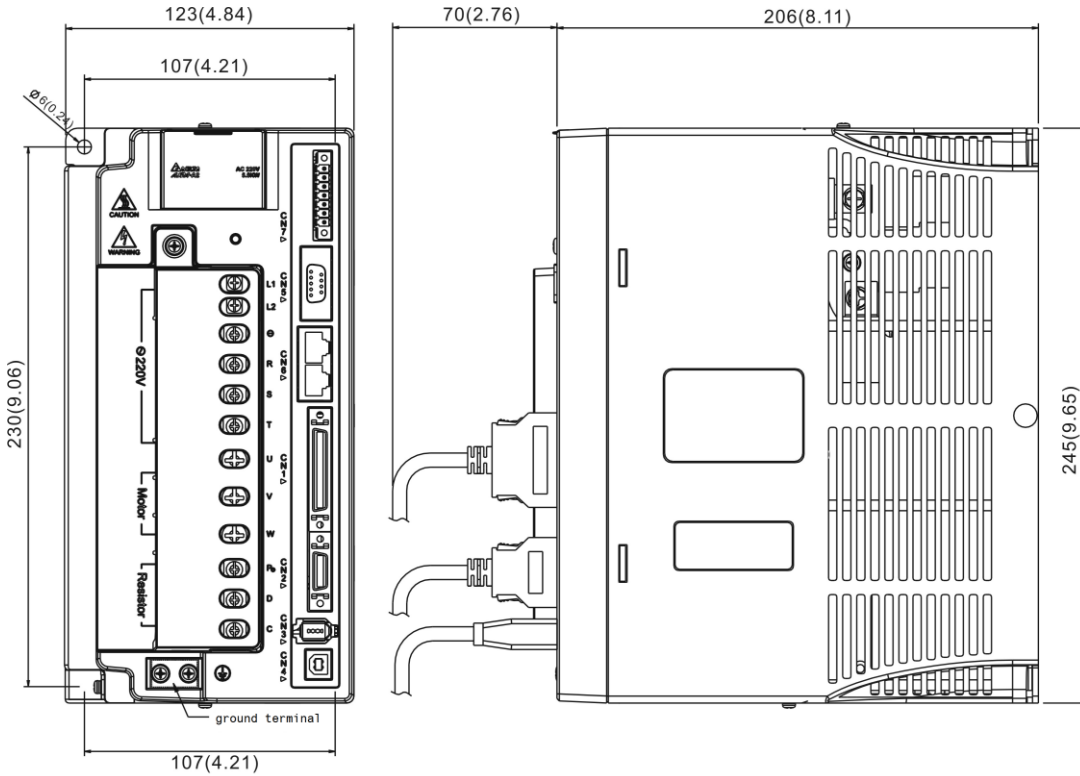

screw: M4 x 0.7
tightening torque: 14 (kgf-cm)

Weight
5.5 (12.1)

Note:

1. Dimensions are in millimeters (inches); weights are in kilograms (kg) and (pounds (lbs)).
2. Dimensions and weights of the servo drive may be revised without prior notice.

ASD-A2-7523 (7.5 kW)

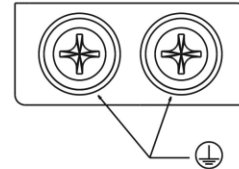
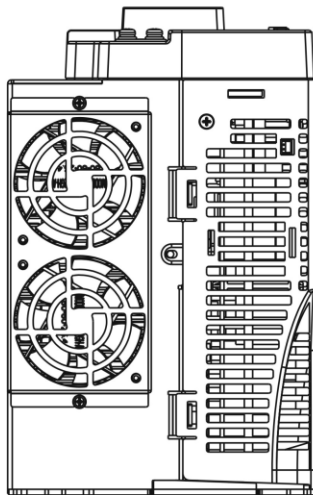
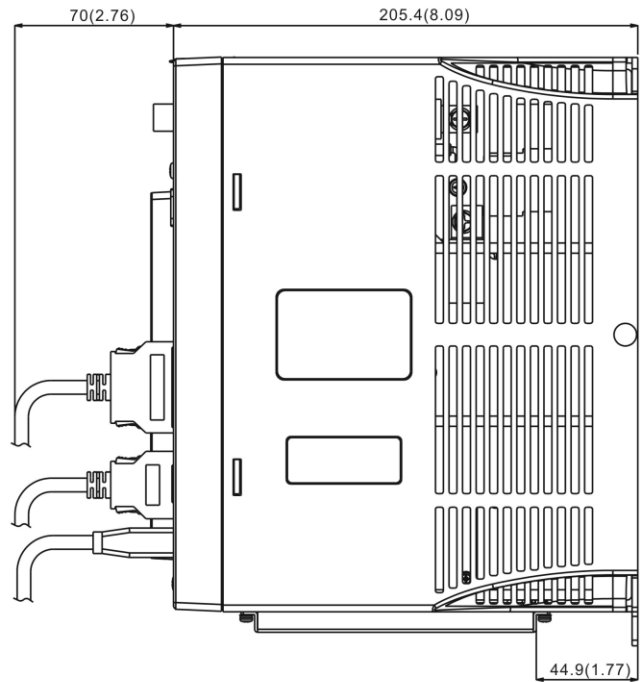
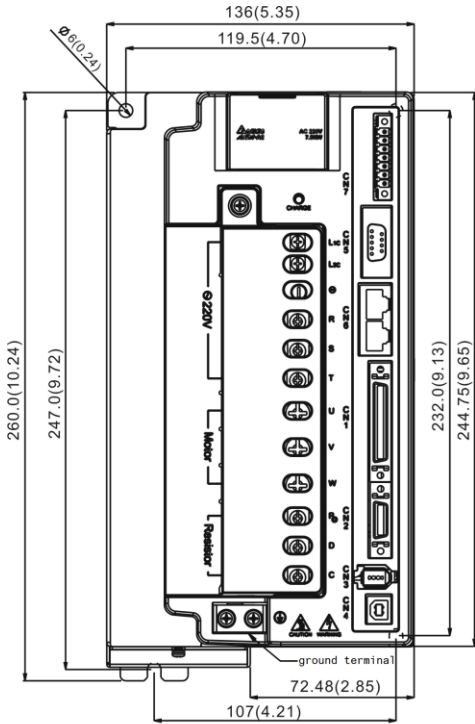

screw: M4 x 0.7
tightening torque: 14 (kgf-cm)

Weight
5.9 (13)

Note:

1. Dimensions are in millimeters (inches); weights are in kilograms (kg) and (pounds (lbs)).
2. Dimensions and weights of the servo drive may be revised without prior notice.

ASD-A2-1B23 (11 kW); ASD-A2-1F23 (15 kW)

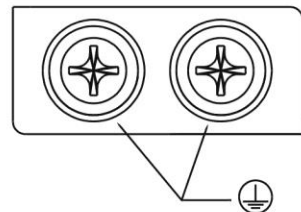
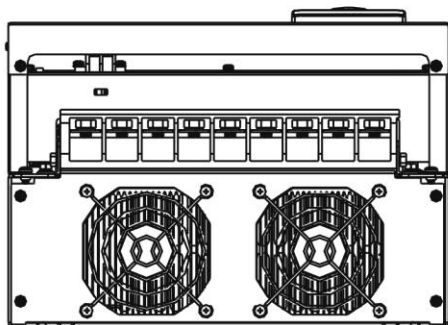
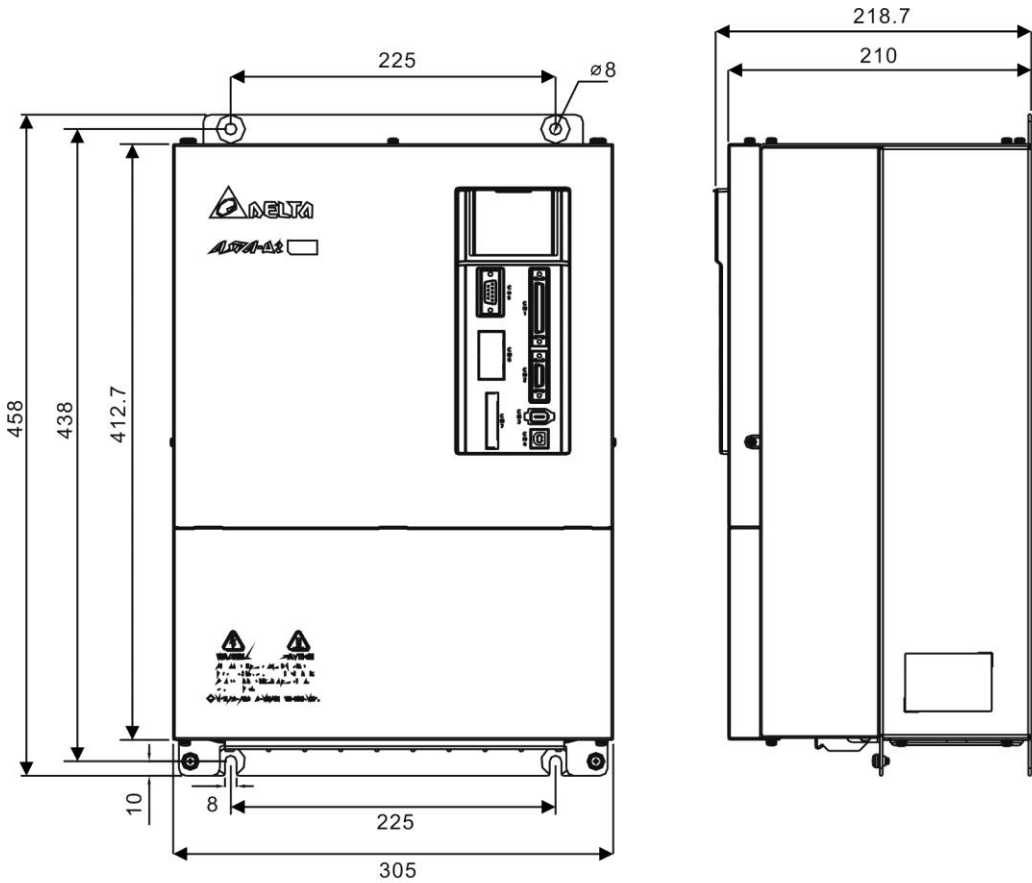

Screw: M 4 X 0.7
Screw Torque: 14 (kgf-cm)

Weight
20 (44)

Note:

1. Dimensions are in millimeters (inches); weights are in kilograms (kg) and (pounds (lbs)).
2. Dimensions and weights of the servo drive may be revised without prior notice.

11.5.2 400V Series

ASD-A2-0743; ASD-A2-1043; ASD-A2-1543 (750 W ~ 1.5 kW)

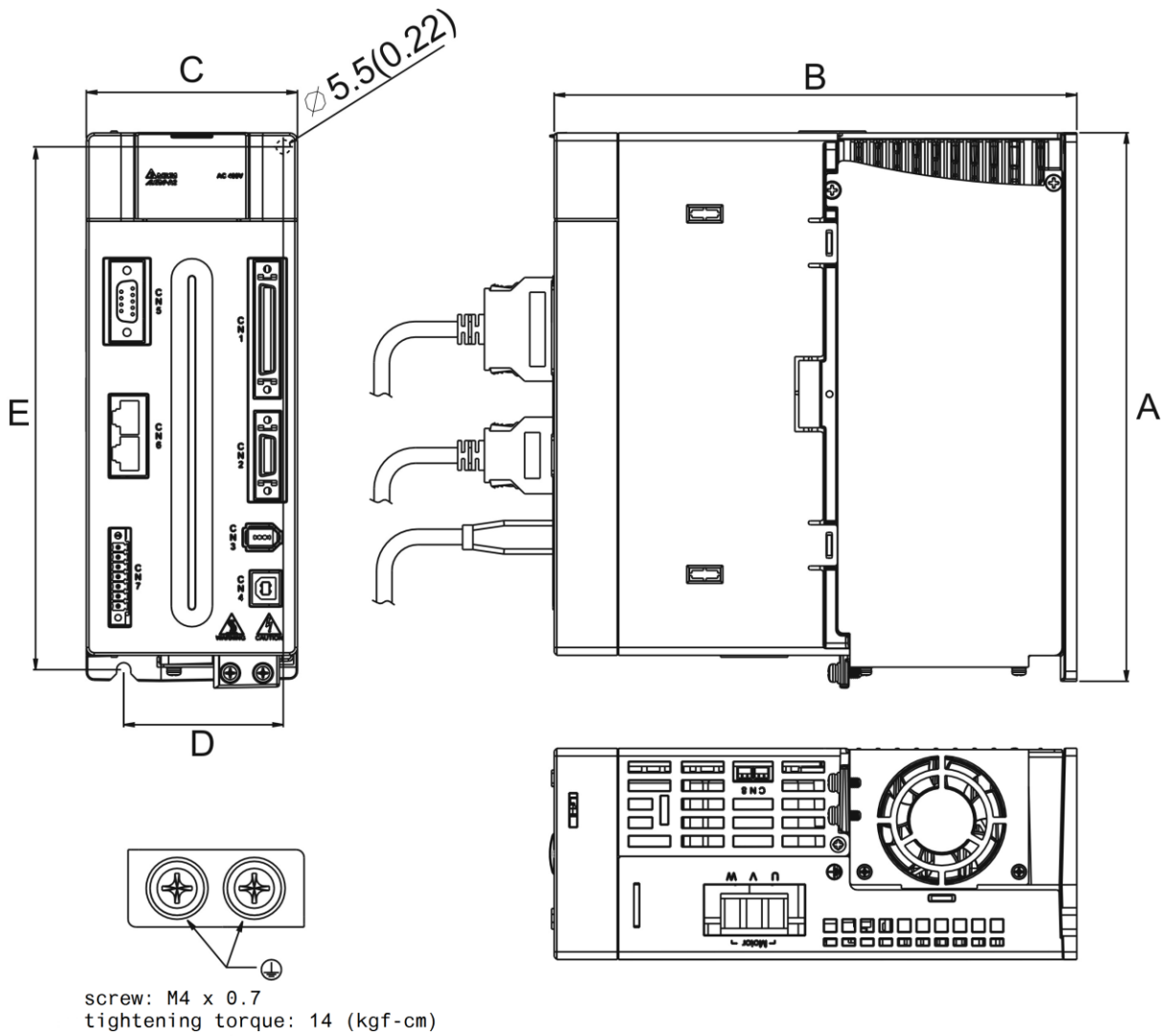

ASD-A2-2043; ASD-A2-3043, ASD-A2-4543; ASD-A2-5543 (2 kW ~ 5.5 kW)

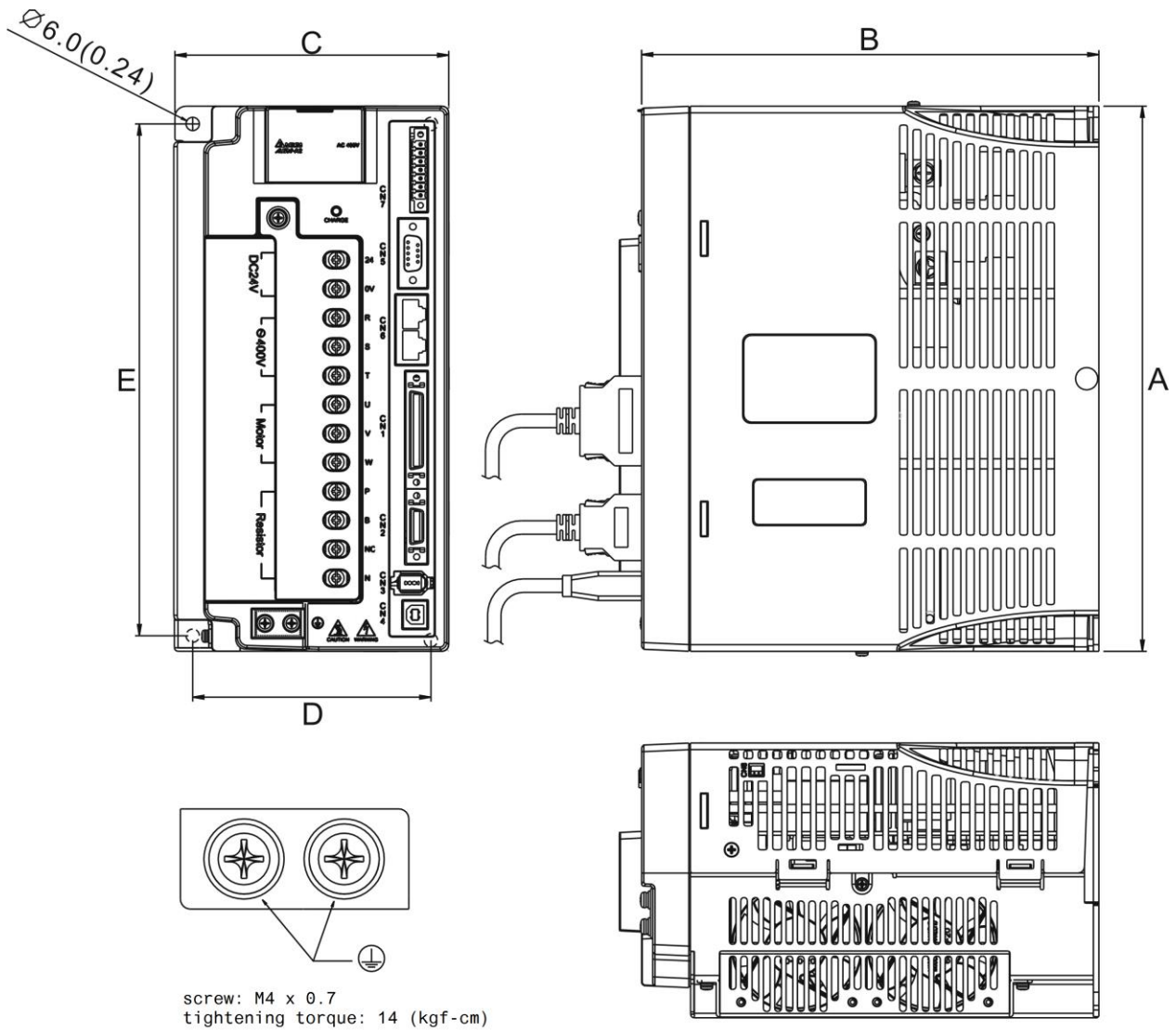

Power	A	B	C	D	E	Weight
750 W~ 1.5 kW	216 (8.50)	203 (7.99)	82 (3.23)	62 (2.44)	203 (7.99)	2.89 (6.36)
2 kW ~ 5.5 kW	245 (9.65)	205.4 (8.09)	123 (4.88)	107 (4.21)	230 (9.06)	5.5 (12.1)

ASD-A2-7543 (7.5 kW)

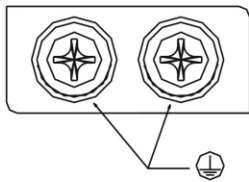
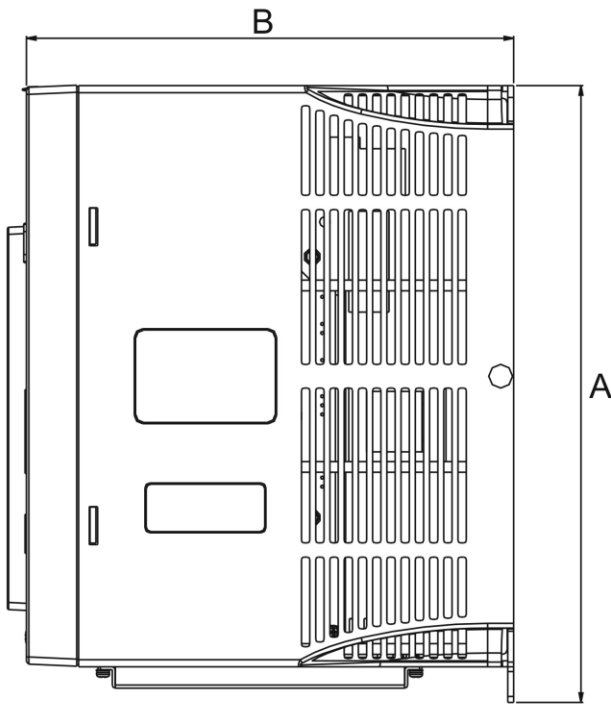
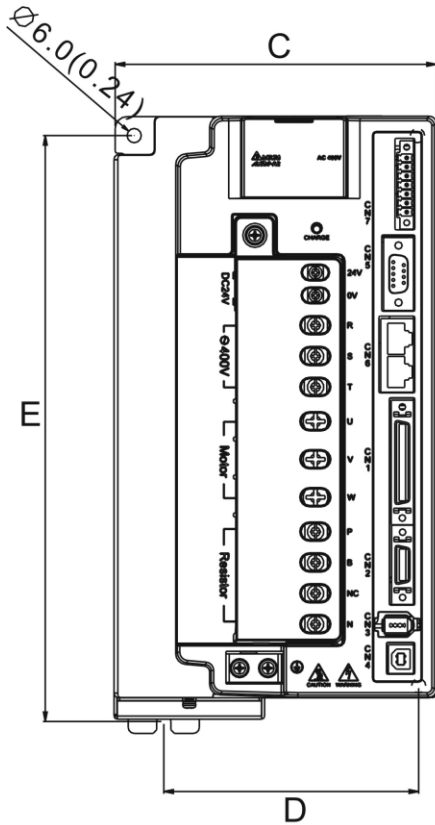

screw: M4 x 0.7
tightening torque: 14 (kgf-cm)

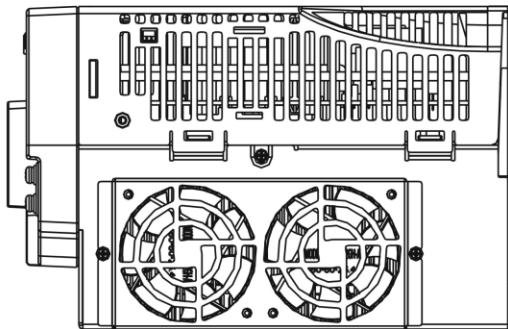

Power	A	B	C	D	E	Weight
7.5 kW	254.2 (10.01)	205.5 (8.09)	136 (5.35)	107 (4.21)	247 (9.72)	5.5 (12.1)

Note:

1. Dimensions are in millimeters (inches).
2. Weights are in kilograms (kg) and (pounds (lbs)).
3. The servo drive images shown here may differ from actual product appearance. Please refer to actual product appearance.
4. Actual measured values are in metric units. Dimensions and weights (in imperial units) are for reference only.

11.6 Dimensions of Servo Motors (ECMA Series)

11.6.1 220V Series

Motor Frame Size: 86 mm and below Models (Units: mm)

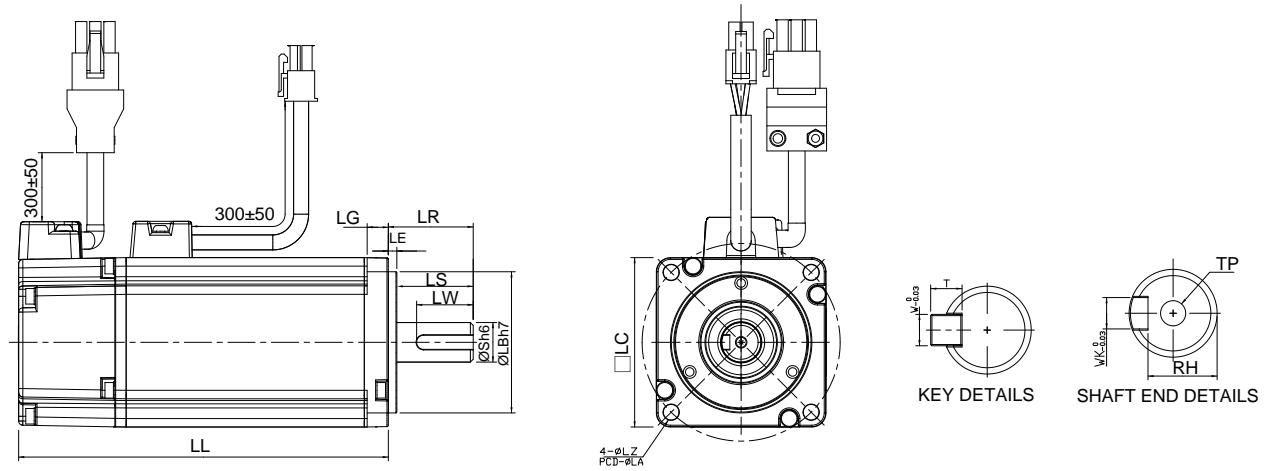

Model	C1040F□S	C△0401□S	C△0602□S	C△0604□S	C△0604□H
LC	40	40	60	60	60
LZ	4.5	4.5	5.5	5.5	5.5
LA	46	46	70	70	70
S	8 ^(+0/-0.009)	8 ^(+0/-0.009)	14 ^(+0/-0.011)	14 ^(+0/-0.011)	14 ^(+0/-0.011)
LB	30 ^(+0/-0.021)	30 ^(+0/-0.021)	50 ^(+0/-0.025)	50 ^(+0/-0.025)	50 ^(+0/-0.025)
LL (without brake)	79.1	100.6	105.5	130.7	145.8
LL (with brake)	--	136.8	141.6	166.8	176.37
LS	20	20	27	27	27
LR	25	25	30	30	30
LE	2.5	2.5	3	3	3
LG	5	5	7.5	7.5	7.5
LW	16	16	20	20	20
RH	6.2	6.2	11	11	11
WK	3	3	5	5	5
W	3	3	5	5	5
T	3	3	5	5	5
TP	M3 Depth 8	M3 Depth 8	M4 Depth 15	M4 Depth 15	M4 Depth 15

Note:

1. Dimensions are in millimeters. Actual measured values are in metric units.
2. Dimensions of the servo motor may be revised without prior notice.
3. The boxes (□) in the model names represent shaft end/brake or the number of oil seal.
4. Please refer to Chapter 1 for the boxes (△) in the model names (which represent encoder type).

Motor frame size: 86 mm and below Models (Units: mm)

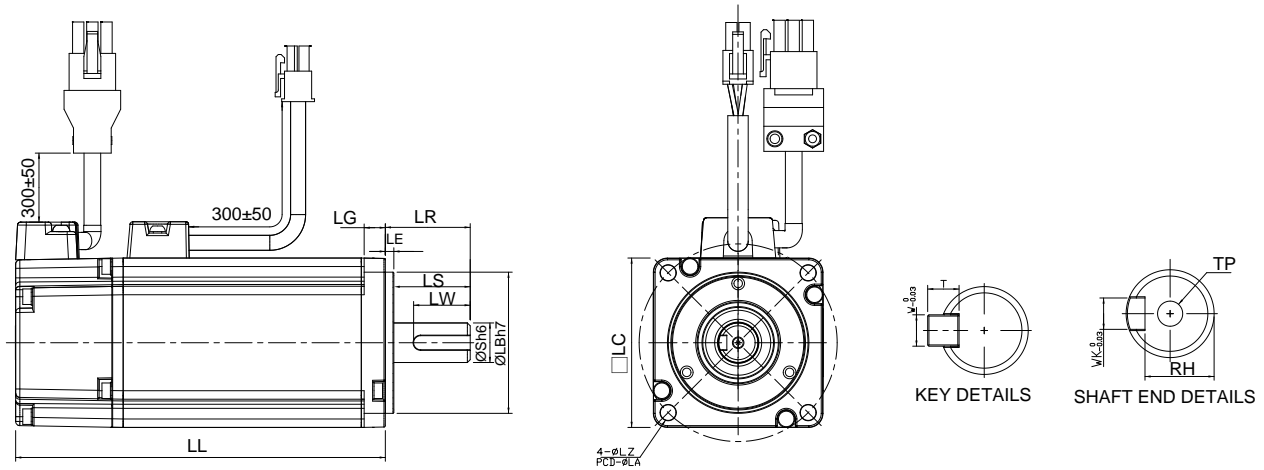

Model	C Δ 0804 \square 7	C Δ 0807 \square S	C Δ 0807 \square H	C Δ 0907 \square S	C Δ 0910 \square S
LC	80	80	80	86	86
LZ	6.6	6.6	6.6	6.6	6.6
LA	90	90	90	100	100
S	14 $^{+0}_{-0.011}$	19 $^{+0}_{-0.013}$	19 $^{+0}_{-0.013}$	16 $^{+0}_{-0.011}$	16 $^{+0}_{-0.011}$
LB	70 $^{+0}_{-0.030}$	70 $^{+0}_{-0.030}$	70 $^{+0}_{-0.030}$	80 $^{+0}_{-0.030}$	80 $^{+0}_{-0.030}$
LL (without brake)	112.3	138.3	154.8	130.2	153.2
LL (with brake)	152.8	178	187.8	161.3	184.3
LS	27	32	32	30	30
LR	30	35	35	35	35
LE	3	3	3	3	3
LG	8	8	8	8	8
LW	20	25	25	20	20
RH	11	15.5	15.5	13	13
WK	5	6	6	5	5
W	5	6	6	5	5
T	5	6	6	5	5
TP	M4 Depth 15	M6 Depth 20	M6 Depth 20	M5 Depth 15	M5 Depth 15

Note:

1. Dimensions are in millimeters. Actual measured values are in metric units.
2. Dimensions of the servo motor may be revised without prior notice.
3. The boxes (\square) in the model names represent shaft end/brake or the number of oil seal.
4. Please refer to Chapter 1 for the boxes (Δ) in the model names (which represent encoder type).

Motor Frame Size: 100 mm ~ 130 mm Models (Units: mm)

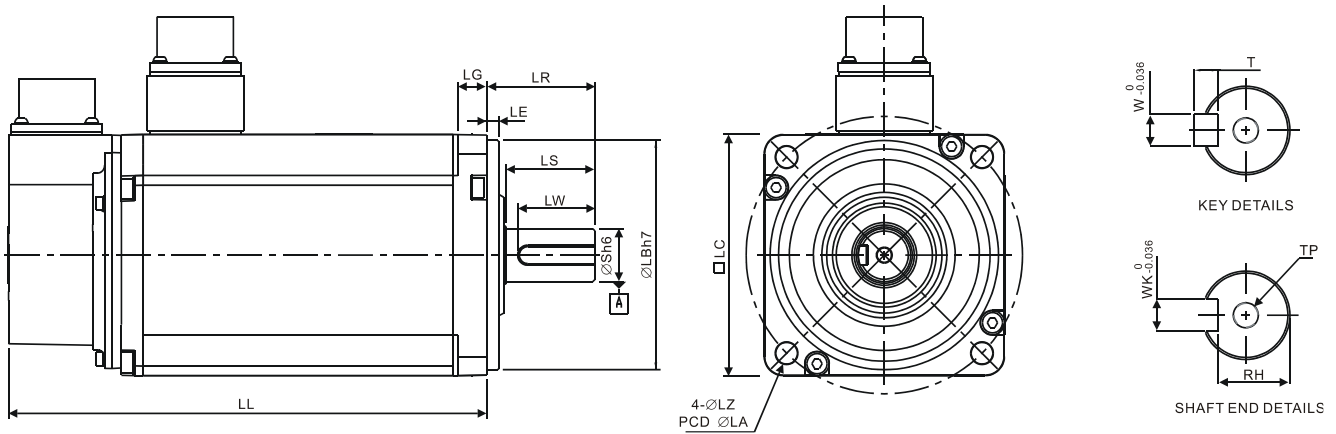

Model	C△1010□S	C△1020□S	C△1330□4	E△1305□S	E△1310□S	E△1315□S	E△1320□S
LC	100	100	130	130	130	130	130
LZ	9	9	9	9	9	9	9
LA	115	115	145	145	145	145	145
S	22 ⁺⁰ _{-0.013}	22 ⁺⁰ _{-0.013}	24 ⁺⁰ _{-0.013}	22 ⁺⁰ _{-0.013}	22 ⁺⁰ _{-0.013}	22 ⁺⁰ _{-0.013}	22 ⁺⁰ _{-0.013}
LB	95 ⁺⁰ _{-0.035}	95 ⁺⁰ _{-0.035}	110 ⁺⁰ _{-0.035}	110 ⁺⁰ _{-0.035}	110 ⁺⁰ _{-0.035}	110 ⁺⁰ _{-0.035}	110 ⁺⁰ _{-0.035}
LL (without brake)	153.3	199.0	187.5	147.5	147.5	167.5	187.5
LL (with brake)	192.5	226.0	216.0	183.5	183.5	202.0	216.0
LS	37	37	47	47	47	47	47
LR	45	45	55	55	55	55	55
LE	5	5	6	6	6	6	6
LG	12	12	11.5	11.5	11.5	11.5	11.5
LW	32	32	36	36	36	36	36
RH	18	18	20	18	18	18	18
WK	8	8	8	8	8	8	8
W	8	8	8	8	8	8	8
T	7	7	7	7	7	7	7
TP	M6 Depth 20	M6 Depth 20	M6 Depth 20	M6 Depth 20	M6 Depth 20	M6 Depth 20	M6 Depth 20

Note:

1. Dimensions are in millimeters. Actual measured values are in metric units.
2. Dimensions of the servo motor may be revised without prior notice.
3. The boxes (□) in the model names represent shaft end/brake or the number of oil seal.
4. Please refer to Chapter 1 for the boxes (△) in the model names (which represent encoder type).

Motor Frame Size: 100 mm ~ 130 mm Models (Units: mm)

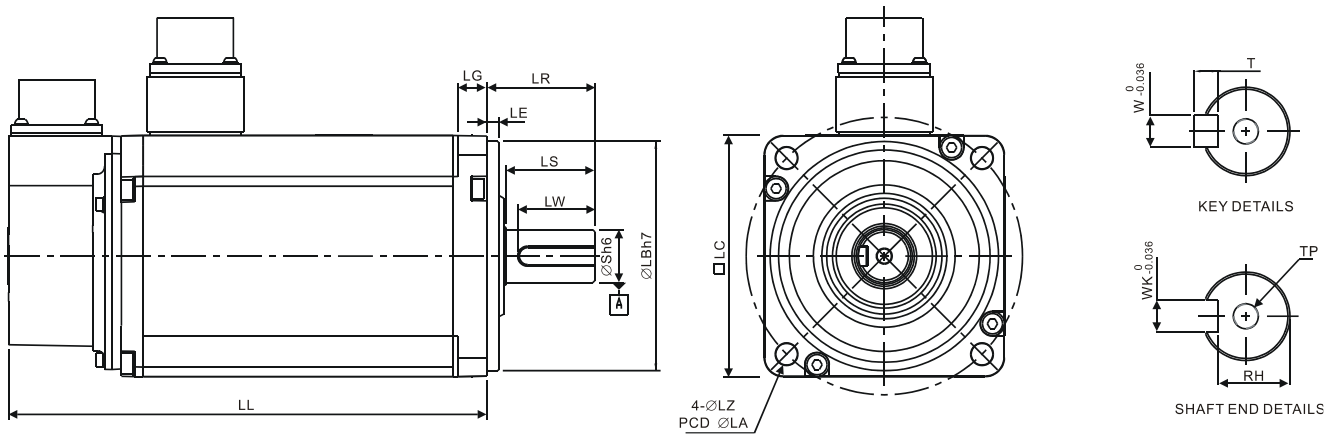

Model	F Δ 1305 \square S	F Δ 1308 \square S	F Δ 1313 \square S	F Δ 1318 \square S	G Δ 1303 \square S	G Δ 1306 \square S	G Δ 1309 \square S
LC	130	130	130	130	130	130	130
LZ	9	9	9	9	9	9	9
LA	145	145	145	145	145	145	145
S	22 $^{+0}_{-0.013}$	22 $^{+0}_{-0.013}$	22 $^{+0}_{-0.013}$	22 $^{+0}_{-0.013}$	22 $^{+0}_{-0.013}$	22 $^{+0}_{-0.013}$	22 $^{+0}_{-0.013}$
LB	110 $^{+0}_{-0.035}$	110 $^{+0}_{-0.035}$	110 $^{+0}_{-0.035}$	110 $^{+0}_{-0.035}$	110 $^{+0}_{-0.035}$	110 $^{+0}_{-0.035}$	110 $^{+0}_{-0.035}$
LL (without brake)	139.5	152.5	187.5	202.0	147.5	147.5	163.5
LL (with brake)	168.0	181.0	216.0	230.7	183.5	183.5	198
LS	47	47	47	47	47	47	47
LR	55	55	55	55	55	55	55
LE	6	6	6	6	6	6	6
LG	11.5	11.5	11.5	11.5	11.5	11.5	11.5
LW	36	36	36	36	36	36	36
RH	18	18	18	18	18	18	18
WK	8	8	8	8	8	8	8
W	8	8	8	8	8	8	8
T	7	7	7	7	7	7	7
TP	M6 Depth 20	M6 Depth 20	M6 Depth 20	M6 Depth 20	M6 Depth 20	M6 Depth 20	M6 Depth 20

Note:

1. Dimensions are in millimeters. Actual measured values are in metric units.
2. Dimensions of the servo motor may be revised without prior notice.
3. The boxes (\square) in the model names represent shaft end/brake or the number of oil seal.
4. Please refer to Chapter 1 for the boxes (Δ) in the model names (which represent encoder type).

Motor Frame Size: 180 mm and above Models (Units: mm)

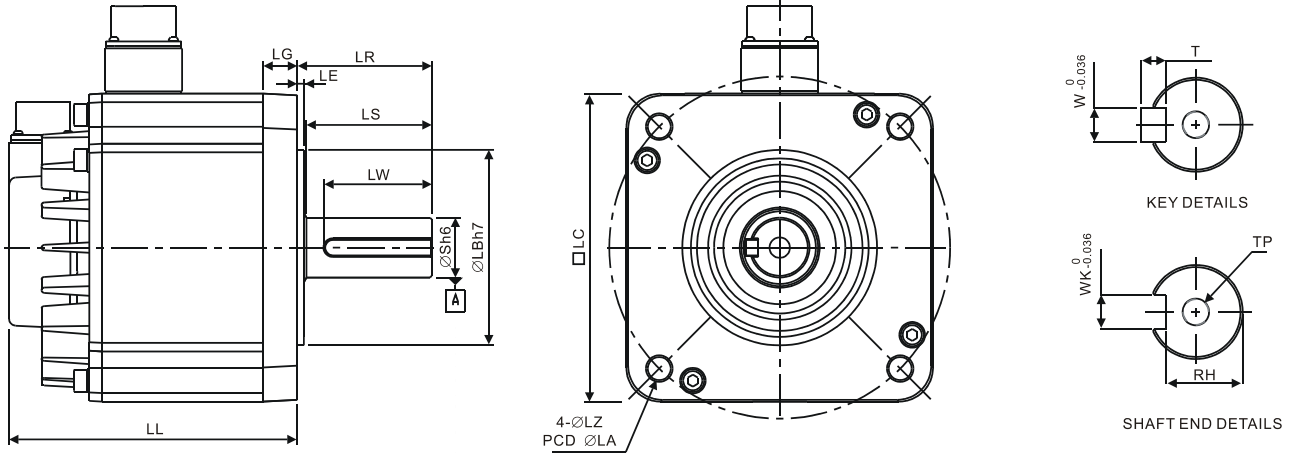

Model	E△1820□S	E△1830□S	E△1835□S	F△1830□S
LC	180	180	180	180
LZ	13.5	13.5	13.5	13.5
LA	200	200	200	200
S	35 ⁺⁰ _{-0.016}	35 ⁺⁰ _{-0.016}	35 ⁺⁰ _{-0.016}	35 ⁺⁰ _{-0.016}
LB	114.3 ⁺⁰ _{-0.035}	114.3 ⁺⁰ _{-0.035}	114.3 ⁺⁰ _{-0.035}	114.3 ⁺⁰ _{-0.035}
LL (without brake)	169.0	202.1	202.1	202.1
LL (with brake)	203.1	235.3	235.3	235.3
LS	73	73	73	73
LR	79	79	79	79
LE	4	4	4	4
LG	20	20	20	20
LW	63	63	63	63
RH	30	30	30	30
WK	10	10	10	10
W	10	10	10	10
T	8	8	8	8
TP	M12 Depth 25	M12 Depth 25	M12 Depth 25	M12 Depth 25

Note:

1. Dimensions are in millimeters. Actual measured values are in metric units.
2. Dimensions of the servo motor may be revised without prior notice.
3. The boxes (□) in the model names represent shaft end/brake or the number of oil seal.
4. Please refer to Chapter 1 for the boxes (△) in the model names (which represent encoder type).

Motor Frame Size: 180 mm Models (Units: mm)

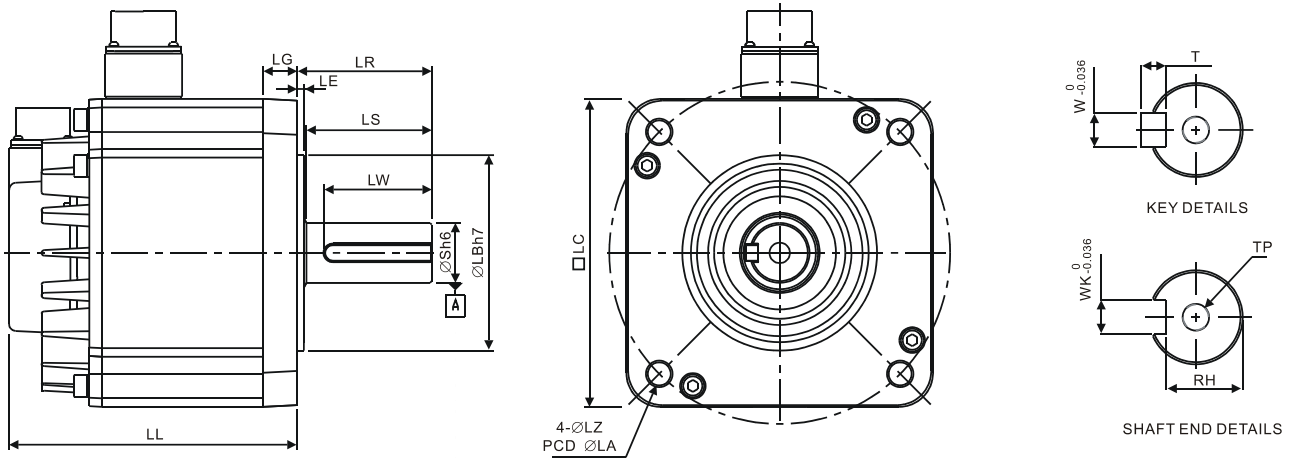

Model	F△1845□S	F△1855□3	F△1875□3
LC	180	180	180
LZ	13.5	13.5	13.5
LA	200	200	200
S	35 ⁺⁰ _{-0.016}	42 ⁺⁰ _{-0.016}	42 ⁺⁰ _{-0.016}
LB	114.3 ⁺⁰ _{-0.035}	114.3 ⁺⁰ _{-0.035}	114.3 ⁺⁰ _{-0.035}
LL (without brake)	235.3	279.7	342.0
LL (with brake)	279.3	311.7	376.1
LS	73	108.5	108.5
LR	79	113	113
LE	4	4	4
LG	20	20	20
LW	63	90	90
RH	30	37	37
WK	10	12	12
W	10	12	12
T	8	8	8
TP	M12 Depth25	M16 Depth32	M16 Depth32

Note:

1. Dimensions are in millimeters. Actual measured values are in metric units.
2. Dimensions of the servo motor may be revised without prior notice.
3. The boxes (□) in the model names represent shaft end/brake or the number of oil seal.
4. Please refer to Chapter 1 for the boxes (△) in the model names (which represent encoder type).

Motor Frame Size: 220 mm and above Models (Units: mm)

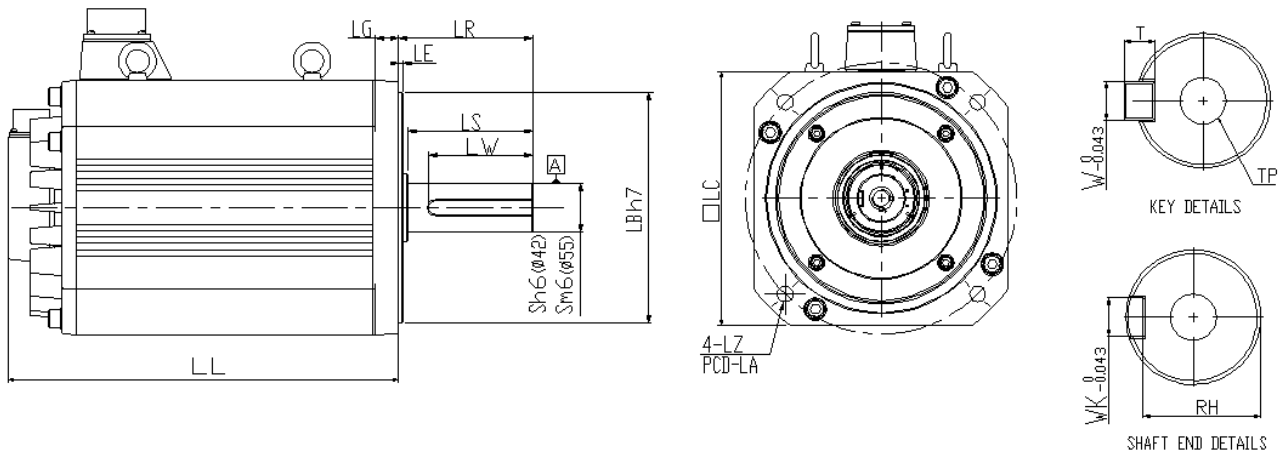

Model	F1221B□3	F1221F□S
LC	220	220
LZ	13.5	13.5
LA	235	235
S	$42^{+0}_{-0.016}$	$55^{+0.03}_{+0.011}$
LB	$200^{+0}_{-0.046}$	$200^{+0}_{-0.046}$
LL (without brake)	371.4	453.4
LL (with brake)	434.4	513.4
LS	108	108
LR	116	116
LE	4	4
LG	20	20
LW	90	90
RH	37	49
WK	12	16
W	12	16
T	8	10
TP	M16 Depth 32	M20 Depth 40

Note:

1. Dimensions are in millimeters. Actual measured values are in metric units.
2. Dimensions of the servo motor may be revised without prior notice.
3. The boxes (□) in the model names represent shaft end/brake or the number of oil seal.
4. Please refer to Chapter 1 for the boxes (△) in the model names (which represent encoder type).

11.6.2 400V Series

Motor Frame Size: 86 mm and below Models (Units: mm)

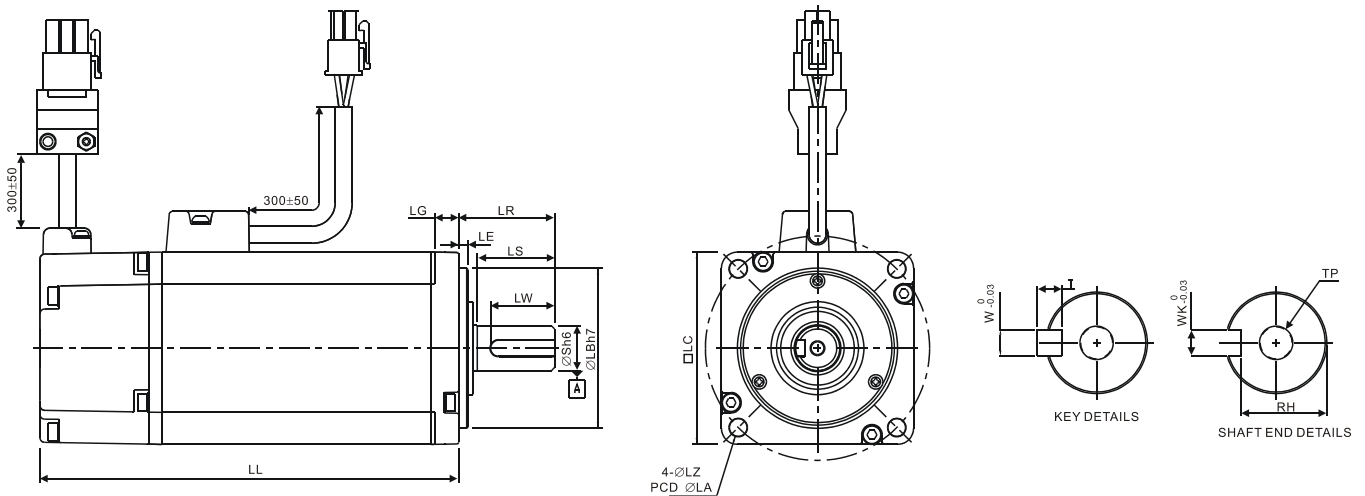

Model	J Δ 0604□S	J Δ 0807□S	J Δ 0907□S	J Δ 0910□S
LC	60	80	86	86
LZ	5.5	6.6	6.6	6.6
LA	70	90	100	100
S	$14^{(+0}_{-0.011)}$	$19^{(+0}_{-0.013)}$	$16^{(+0}_{-0.011)}$	$16^{(+0}_{-0.011)}$
LB	$50^{(+0}_{-0.025)}$	$70^{(+0}_{-0.030)}$	$80^{(+0}_{-0.030)}$	$80^{(+0}_{-0.030)}$
LL (without brake)	130.7	138.3	130.2	153.2
LL (with brake)	166.8	178.0	161.3	184.3
LS (without oil seal)	27	32	30	30
LS (with oil seal)	--	29.5	30	30
LR	30	35	35	35
LE	3	3	3	3
LG	7.5	8	8	8
LW	20	25	20	20
RH	11	15.5	13	13
WK	5	6	5	5
W	5	6	5	5
T	5	6	5	5
TP	M4 Depth 15	M6 Depth 20	M5 Depth 15	M5 Depth 15

Note:

1. Dimensions are in millimeters. Actual measured values are in metric units.
2. Dimensions of the servo motor may be revised without prior notice.
3. The boxes (□) in the model names represent shaft end/brake or the number of oil seal.
4. Please refer to Chapter 1 for the boxes (Δ) in the model names (which represent encoder type).

Motor Frame Size: 100 mm Models (Units: mm)

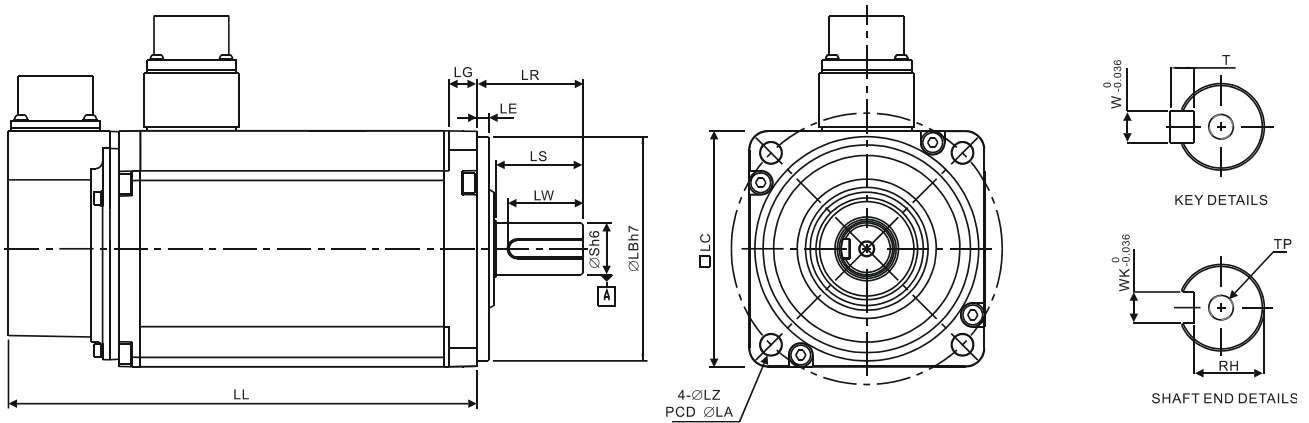

Model	J Δ 1010□S	J Δ 1020□S
LC	100	100
LZ	9	9
LA	115	115
S	22 ^(+0/-0.013)	22 ^(+0/-0.013)
LB	95 ^(+0/-0.035)	95 ^(+0/-0.035)
LL (without brake)	153.3	199.0
LL (with brake)	192.5	226.0
LS	37	37
LR	45	45
LE	5	5
LG	12	12
LW	32	32
RH	18	18
WK	8	8
W	8	8
T	7	7
TP	M6 Depth 20	M6 Depth 20

Note:

1. Dimensions are in millimeters. Actual measured values are in metric units.
2. Dimensions of the servo motor may be revised without prior notice.
3. The boxes (□) in the model names represent shaft end/brake or the number of oil seal.
4. Please refer to Chapter 1 for the boxes (Δ) in the model names (which represent encoder type).

Motor Frame Size: 130 mm Models (Units: mm)

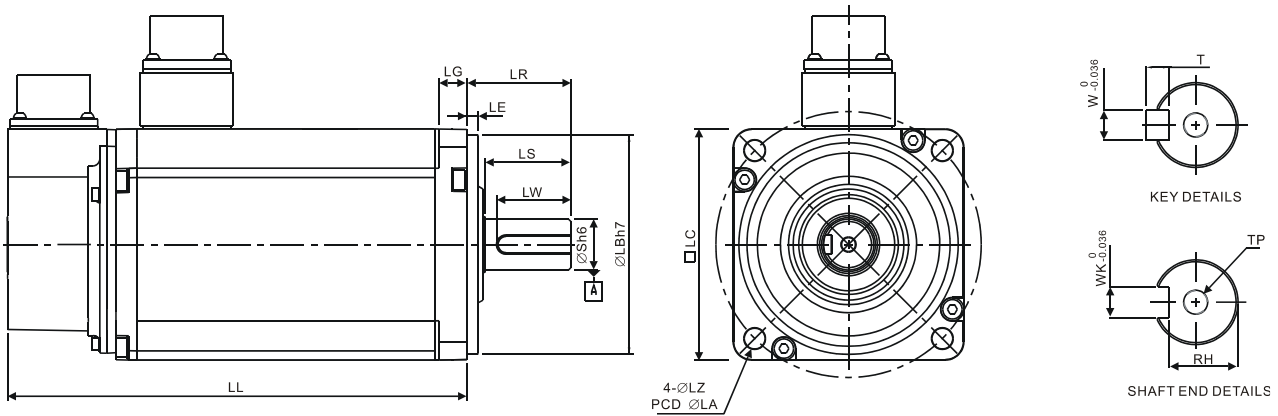

Model	J Δ 1330 \square 4	K Δ 1305 \square S	K Δ 1310 \square S	K Δ 1315 \square S	K Δ 1320 \square S
LC	130	130	130	130	130
LZ	9	9	9	9	9
LA	145	145	145	145	145
S	24 $^{+0}_{-0.013}$	22 $^{+0}_{-0.013}$	22 $^{+0}_{-0.013}$	22 $^{+0}_{-0.013}$	22 $^{+0}_{-0.013}$
LB	110 $^{+0}_{-0.035}$	110 $^{+0}_{-0.035}$	110 $^{+0}_{-0.035}$	110 $^{+0}_{-0.035}$	110 $^{+0}_{-0.035}$
LL (without brake)	187.5	139.5	147.5	167.5	187.5
LL (with brake)	216.0	168.0	183.5	202.0	216.0
LS	47	47	47	47	47
LR	55	55	55	55	55
LE	6	6	6	6	6
LG	11.5	11.5	11.5	11.5	11.5
LW	36	36	36	36	36
RH	20	18	18	18	18
WK	8	8	8	8	8
W	8	8	8	8	8
T	7	7	7	7	7
TP	M6 Depth 20	M6 Depth 20	M6 Depth 20	M6 Depth 20	M6 Depth 20

Note:

1. Dimensions are in millimeters. Actual measured values are in metric units.
2. Dimensions of the servo motor may be revised without prior notice.
3. The boxes (\square) in the model names represent shaft end/brake or the number of oil seal.
4. Please refer to Chapter 1 for the boxes (Δ) in the model names (which represent encoder type).

Motor Frame Size: 130 mm Models (Units: mm)

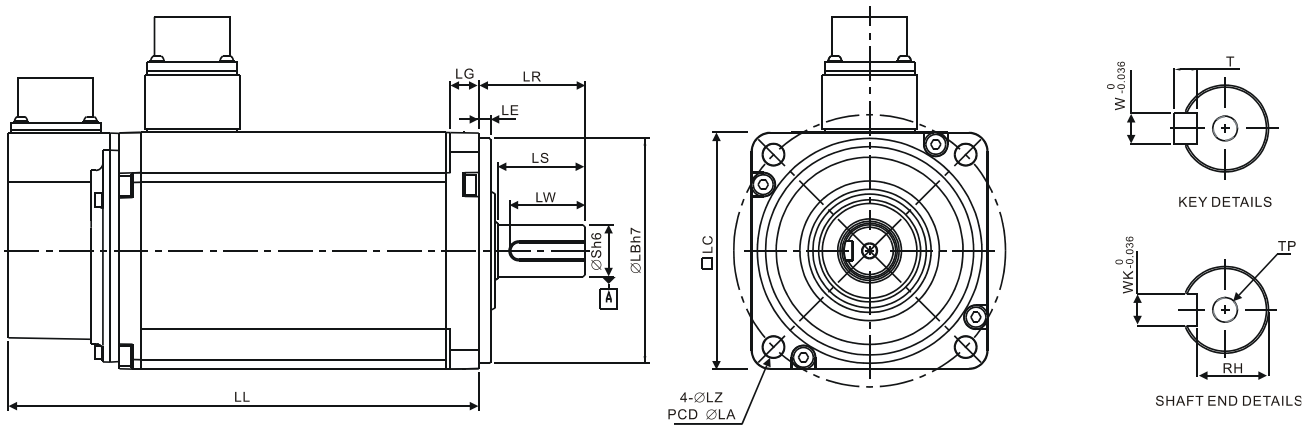

Model	L Δ 1305 \square S	L Δ 1313 \square S	L Δ 1308 \square S	L Δ 1318 \square S	M Δ 1309 \square S
LC	130	130	130	130	130
LZ	9	9	9	9	9
LA	145	145	145	145	145
S	22 $^{+0}_{-0.013}$	22 $^{+0}_{-0.013}$	22 $^{+0}_{-0.013}$	22 $^{+0}_{-0.013}$	22 $^{+0}_{-0.013}$
LB	110 $^{+0}_{-0.035}$	110 $^{+0}_{-0.035}$	110 $^{+0}_{-0.035}$	110 $^{+0}_{-0.035}$	110 $^{+0}_{-0.035}$
LL (without brake)	147.5	194.5	163.5	194.5	163.5
LL (with brake)	168.0	223.0	181.0	-	198.0
LS	47	47	47	47	47
LR	55	55	55	55	55
LE	6	6	6	6	6
LG	11.5	11.5	11.5	11.5	11.5
LW	36	36	36	36	36
RH	18	18	18	18	18
WK	8	8	8	8	8
W	8	8	8	8	8
T	7	7	7	7	7
TP	M8 Depth 25	M6 Depth 20	M6 Depth 20	M6 Depth 20	M6 Depth 20

Note:

1. Dimensions are in millimeters. Actual measured values are in metric units.
2. Dimensions of the servo motor may be revised without prior notice.
3. The boxes (\square) in the model names represent shaft end/brake or the number of oil seal.
4. Please refer to Chapter 1 for the boxes (Δ) in the model names (which represent encoder type).

Motor Frame Size: 180 mm and above Models (Units: mm)

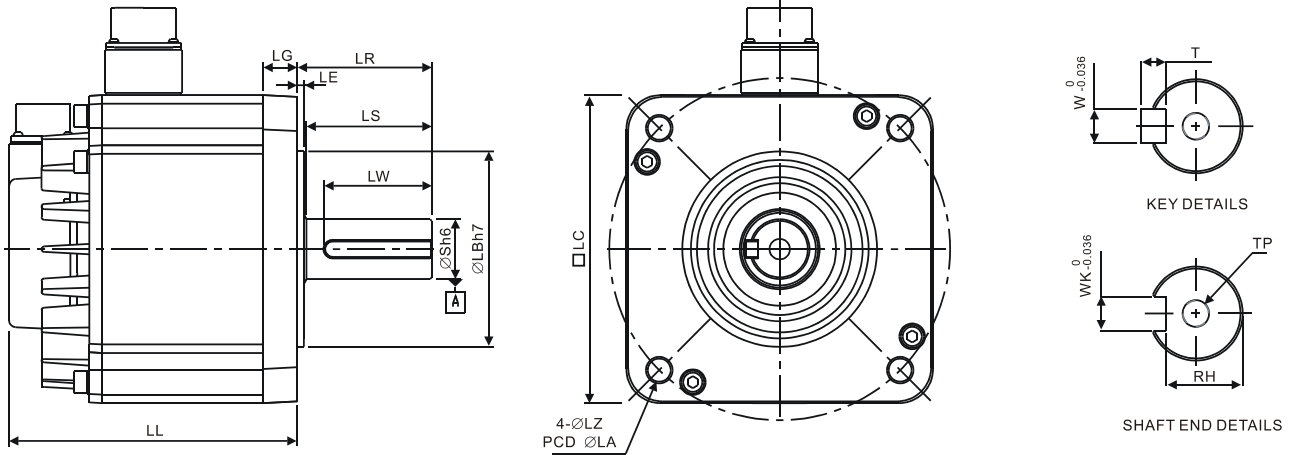

Model	L Δ 1830 \square S	L Δ 1845 \square S	L Δ 1855 \square S	L Δ 1875 \square S	K Δ 1820 \square S
LC	180	180	180	180	180
LZ	13.5	13.5	13.5	13.5	13.5
LA	200	200	200	200	200
S	35 $^{+0}_{-0.016}$	35 $^{+0}_{-0.016}$	42 $^{+0}_{-0.016}$	42 $^{+0}_{-0.016}$	35 $^{+0}_{-0.016}$
LB	114.3 $^{+0}_{-0.035}$	114.3 $^{+0}_{-0.035}$	114.3 $^{+0}_{-0.035}$	114.3 $^{+0}_{-0.035}$	114.3 $^{+0}_{-0.035}$
LL (without brake)	202.1	235.3	279.7	342.0	169.0
LL (with brake)	235.3	279.3	311.7	376.1	203.1
LS	73	73	108.5	108.5	73
LR	79	79	113	113	79
LE	4	4	4	4	4
LG	20	20	20	20	20
LW	63	63	90	90	63
RH	30	30	37	37	30
WK	10	10	12	12	10
W	10	10	12	12	10
T	8	8	8	8	8
TP	M12 Depth 25	M12 Depth 25	M16 Depth 32	M16 Depth 32	M12 Depth 25

Note:

1. Dimensions are in millimeters. Actual measured values are in metric units.
2. Dimensions of the servo motor may be revised without prior notice.
3. The boxes (\square) in the model names represent shaft end/brake or the number.
4. Please refer to Chapter 1 for the boxes (Δ) in the model names (which represent encoder type).

Chapter 12 Absolute System

Introduction

Delta's absolute system includes an ASDA-A2 series servo drive, an ECMA series servo motor with an absolute encoder, and a backup battery box for an absolute encoder. The backup battery supplies power to the system so that the encoder continues to operate even when the power is off. In addition, an absolute encoder in an ECMA series servo motor will constantly record the actual positions by its built-in coordinate system at any time. So the real position of the servo motor will be measured and recorded even if the motor shaft rotates after the power is turned off.

An ECMA series servo motor with an absolute encoder is essential and must be connected with an ASDA-A2 series servo drive for a Delta's absolute system. When an ECMA series servo motor with an incremental encoder is connected to an ASDA-A2 series servo drive, if the users enable the servo parameters for absolute system, a fault code, AL069, will be shown on the drive's LCD display to alert that an error occurs.

Note that when using an absolute motor, as soon as it applies to the power, the motor speed should be lower than 250 rpm. When operating in battery mode, make sure the maximum speed does not exceed 200 rpm. The model name of a servo motor with an absolute encoder is shown as below:

ECMA-□A□□□□□□□□
└─ A: Servo Motor with Absolute Encoder

Install the battery properly with the encoder cable. One servo drive uses one single battery box. Two servo drives can share a dual battery box. We recommend the users to choose Delta's backup battery boxes and Delta's encoder connection cables for Delta's absolute systems for wiring and connection. Regarding the descriptions and specifications of battery boxes and corresponding accessories, please refer to the contents in the following sections.

12.1 Battery Box (absolute type) and wiring

12.1.1 Specifications

Precautions

Please thoroughly understand and observe the following safety precautions. In order to prevent damage and danger, please use batteries in accordance with the specified specification.



- Install the product in a location free of vapor, and corrosive and inflammable gas.
- Do not place the battery dispersedly to prevent short circuit.
- Do not short-circuit the positive pole and the negative pole of the batteries or install batteries in reverse polarity.
- To prevent electric energy loss and lifetime reduction, it is recommended to use new batteries only.
- Please follow the instructions when wiring the battery box to avoid danger.



- Do not store batteries within an ambient temperature above +100°C (212°F). Failure to observe this precaution may cause fire or explosion.
- The batteries are non-rechargeable. Do not charge the batteries, or explosion may occur.
- Do not directly solder the battery surface.

Battery Specifications

Items	Li/SOCI2 Cylindrical Battery
Type	ER14505
Delta Model Number	ASD-CLBT0100
International Standard Size	AA
Standard Voltage	3.6V
Standard Capacity	2700 mAh
Maximum Continuous Discharge Current	100 mA
Maximum Pulse Current	200 mA
Dimensions (D x H)	14.5 x 50.5 mm
Weight	Approx. 19 g
Operating Temperature	-40°C to 85°C (-40°F to 185°F)

Battery Life

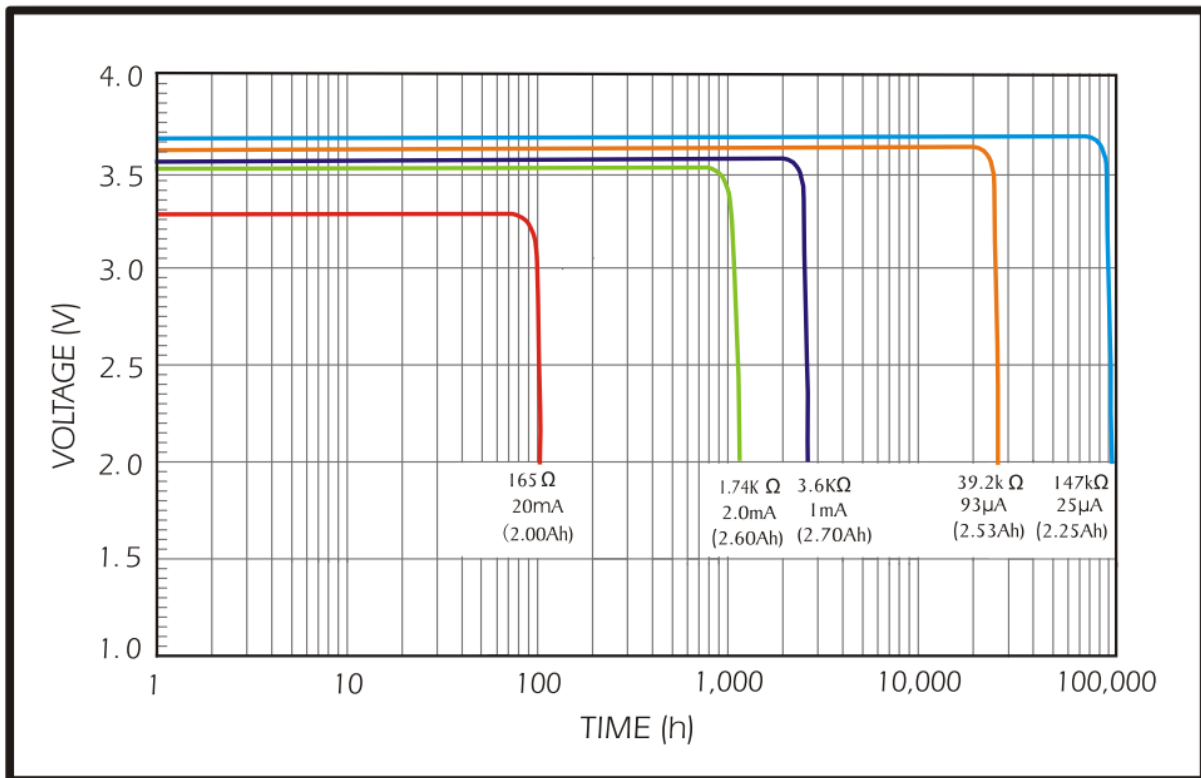

The above figure comes from EVE Energy Co. ER14505 Discharge Characteristics

- (1) The above figure illustrates the discharge current curve generated by constant current test. According to the testing result shown on the graph above, when the power consumption of an absolute encoder is 190 uA or lower, if the voltage of the battery keeps 3V or higher, the expected battery life is about 19.7 months^(Note). Therefore, the lowest voltage level of battery for an absolute encoder is set to 3.1V.
- (2) The battery life expectancy is about 5 years and is able to provide 3.6V or higher voltage under normal temperature and humidity conditions.

Note: the battery life was measured when one single battery box is connecting to one servo drive and one servo motor.

12.1.2 Battery Box Dimensions

Single Battery Box

Delta Model Number: ASD-MDBT0100

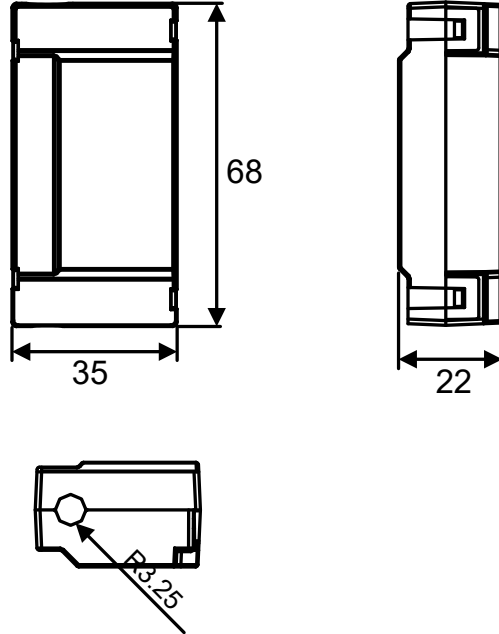

Weight
44 g

Units: mm

Dual Battery Box

Delta Model Number: ASD-MDBT0200

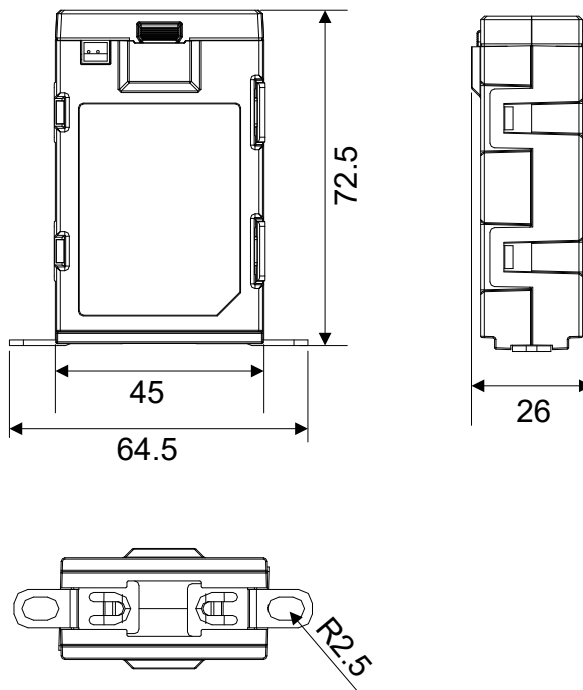

Weight
80 g

Units: mm

12.1.3 Connection Cables for Absolute Encoder

A. Quick Connector

Delta part number: **ASD-A2EB0003, ASD-A2EB0005**

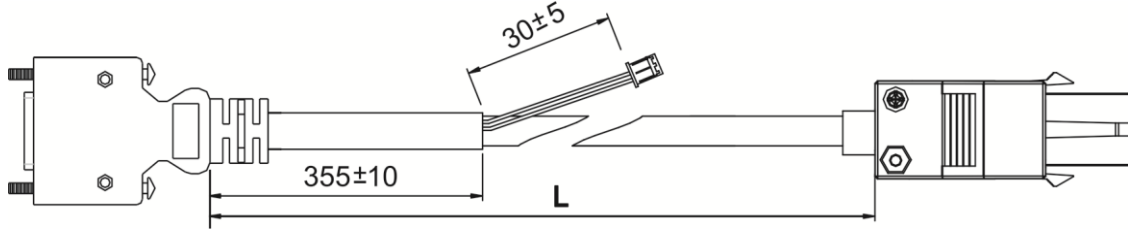

Title	Model Name	L	
		mm	inch
1	ASD-A2EB0003	3000 ± 100	118 ± 4
2	ASD-A2EB0005	5000 ± 100	197 ± 4

Connection method:

Please conduct the wiring according to the following instructions. Wrong wiring might cause battery explosion.

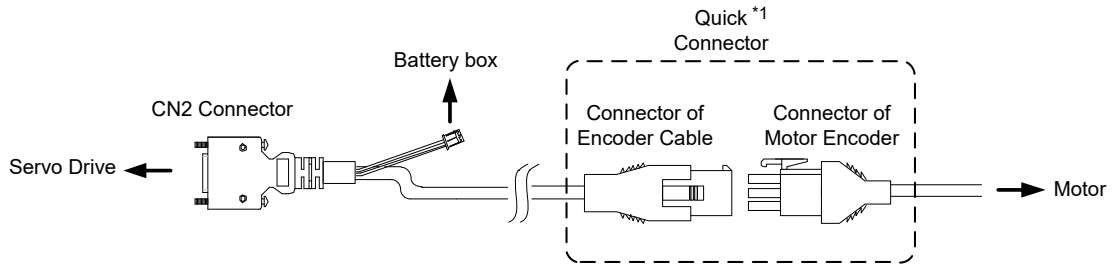

Note 1:

Connector of Encoder Cable
Housing : AMP(1-172161-9)

View from this side

1 White T+	2 Red BAT+	3 Reserved
4 White/Red T-	5 Black BAT-	6 Reserved
7 Brown DC+5V	8 Blue GND	9 Shield

Connector of Motor Encoder

View from this side

3 Reserved	2 Black BAT+	1 White T+
6 Reserved	5 Red/Black BAT-	4 White/Red T-
9 Shield	8 Blue GND	7 Brown DC+5V

The wire color of the servo drive connector is only for reference. Please refer to the real object.

B. Military Connector

Delta part number: **ASD-A2EB1003, ASD-A2EB1005**

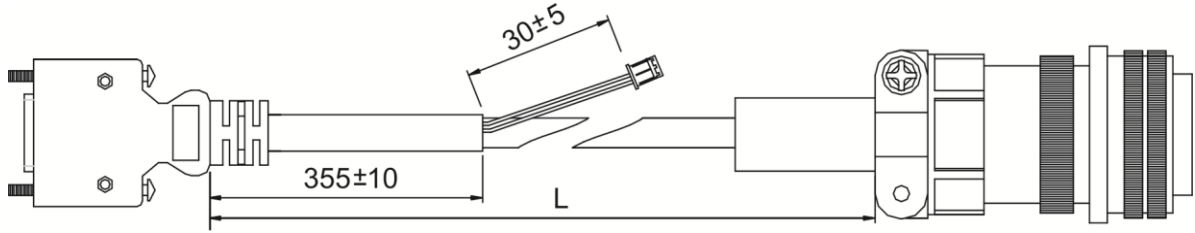

Title	Model Name	L	
		mm	inch
1	ASD-A2EB1003	3000 ± 100	118 ± 4
2	ASD-A2EB1005	5000 ± 100	197 ± 4

Connection method:

Please conduct the wiring according to the following instructions. Wrong wiring might cause battery explosion.

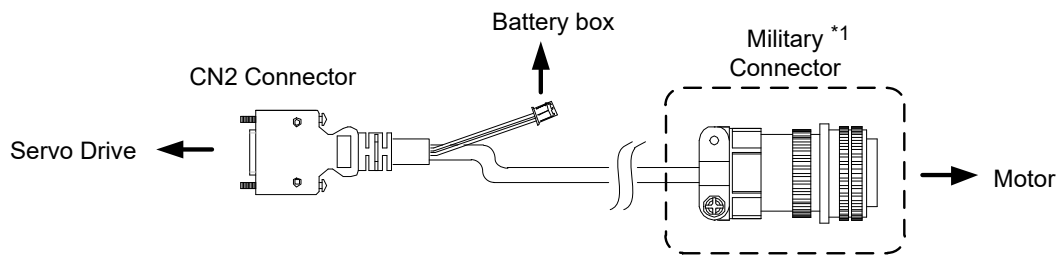

Note 1:

Pin No.	Terminal	Color
A	T+	White
B	T-	White/Red
C	BAT+	Red
D	BAT-	Black
S	DC+5V	Brown
R	GND	Blue
L	BRAID SHIELD	-

**3106A-20-29S
Military Connector**

12.1.4 Battery Box Cords

Battery Box Cord AW

Delta Part Number: 3864573700

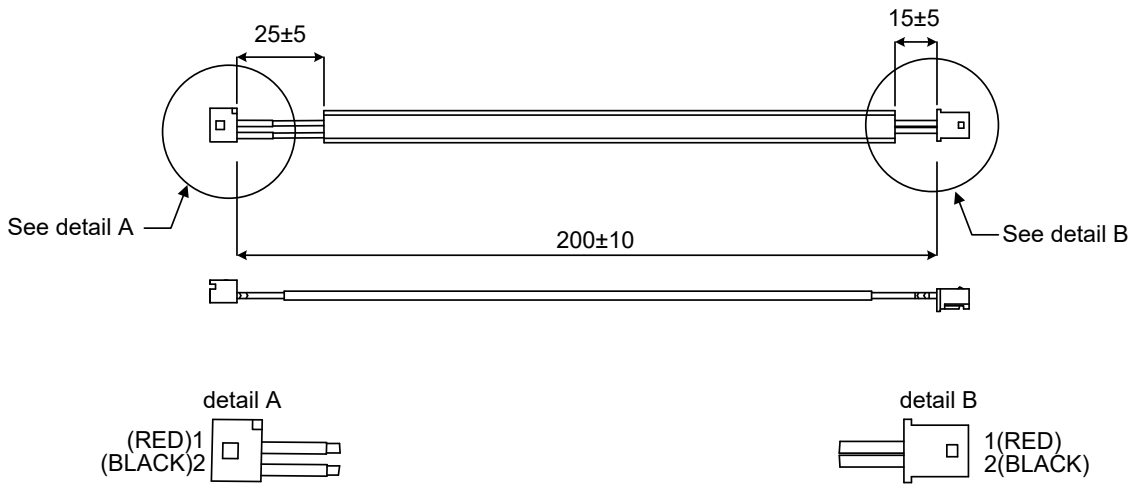

Battery Box Cord IW

Delta Part Number: 3864811900

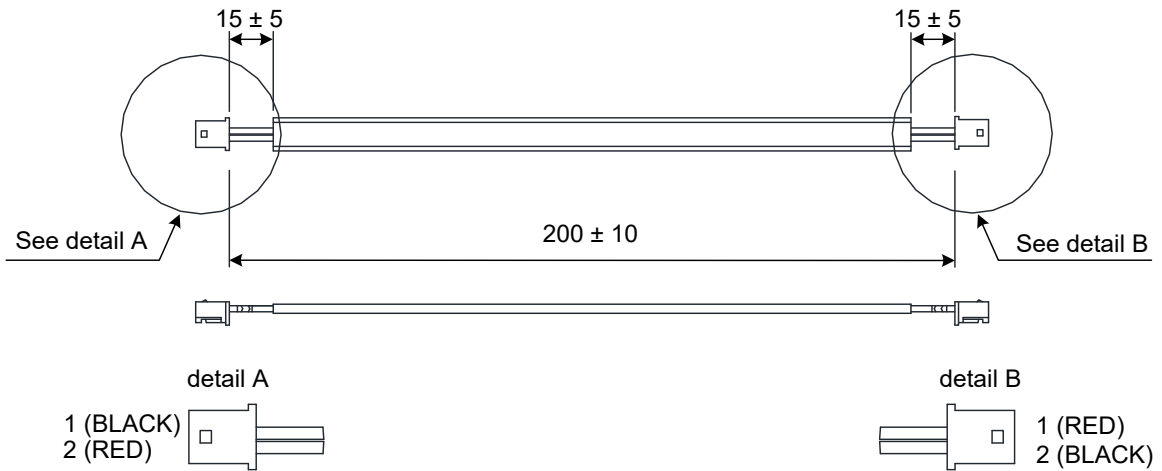

12.2 Installation

12.2.1 Connection Examples

Single Battery Box (Standard wiring)

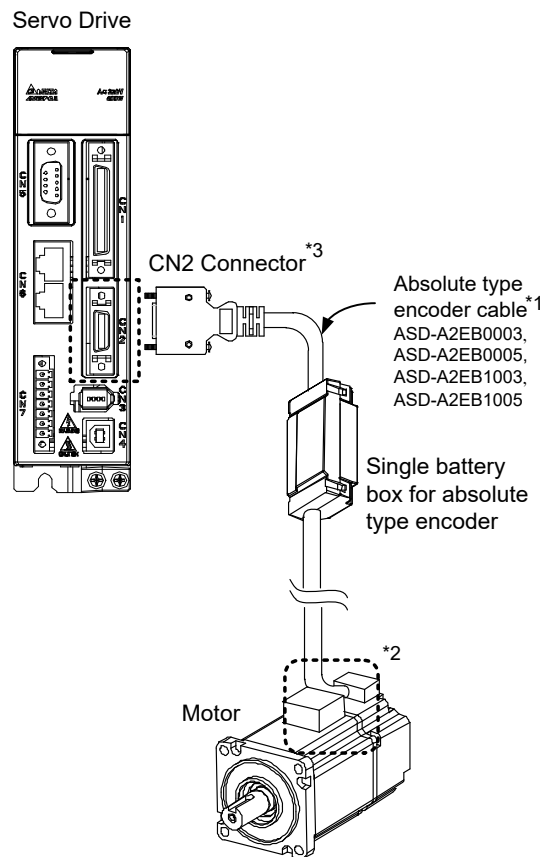

Note:

This is the wiring diagram for connecting to a single battery box. The scale of the objects does not match the dimensions as shown in the drawing above. For different models of AC servo drives and motors, the connection cables may differ.

For 1* and 2*, please refer to section 12.1.3.

3* Definition of CN2 connector

Please conduct the wiring according to the following instructions. Wrong wiring might cause battery explosion.

CN2 Connector			Motor Connector	
Pin No.	Terminal Symbol	Function and Description	Military Connector	Quick Connector
5	T+	Serial communication signal input/output (+)	A	1
4	T-	Serial communication signal input/output (-)	B	4
7	BAT+	Battery 3.6V	C	2
9	BAT-	Battery ground	D	5
14, 16	+5V	Power +5V	S	7
13, 15	GND	Power ground	R	8
-	Shield	Shield	L	9

Single Battery Box (Connect to CN8)

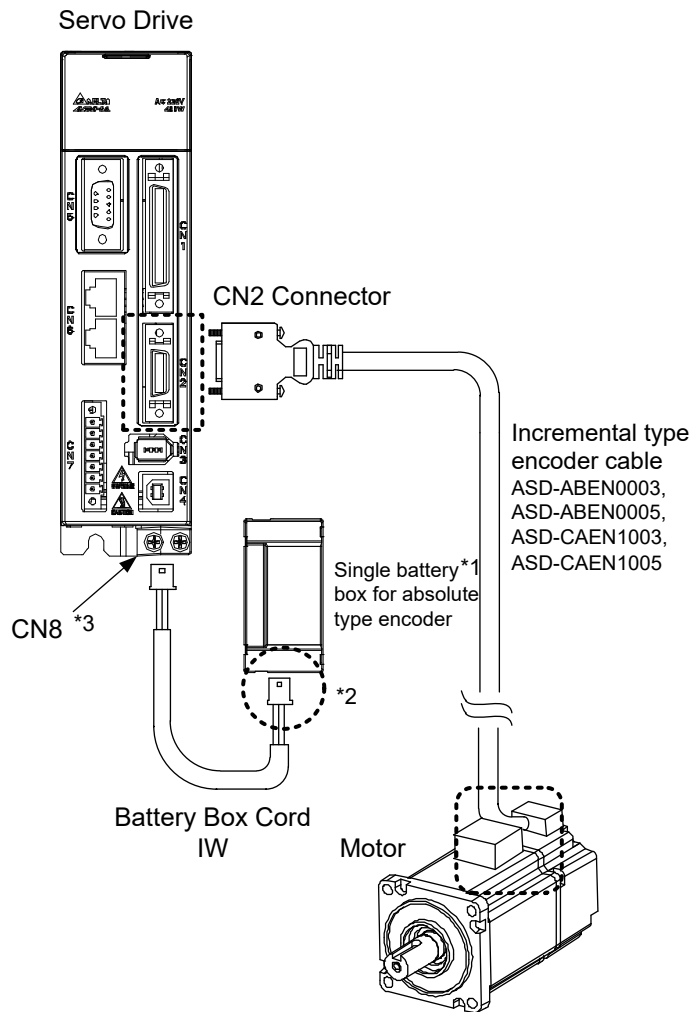

Note:

This is the wiring diagram for connecting to a single battery box. The scale of the objects does not match the dimensions as shown in the drawing above. For different models of AC servo drives and motors, the connection cables may differ.

1* Make sure the battery box is firmly fixed with this connection method.

2* Connect to the power base on a single battery box. See the descriptions below:

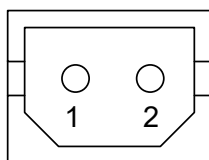

Pin No.	Terminal Symbol	Connector Cable
1	BAT+	Red
2	BAT-	Black

3* Definition of CN8 Connector:

Please conduct the wiring according to the following instructions. Wrong wiring might cause battery explosion.

Pin No.	Terminal Symbol
1	BAT+
2	BAT-

Dual Battery Box (Connect to CN2)

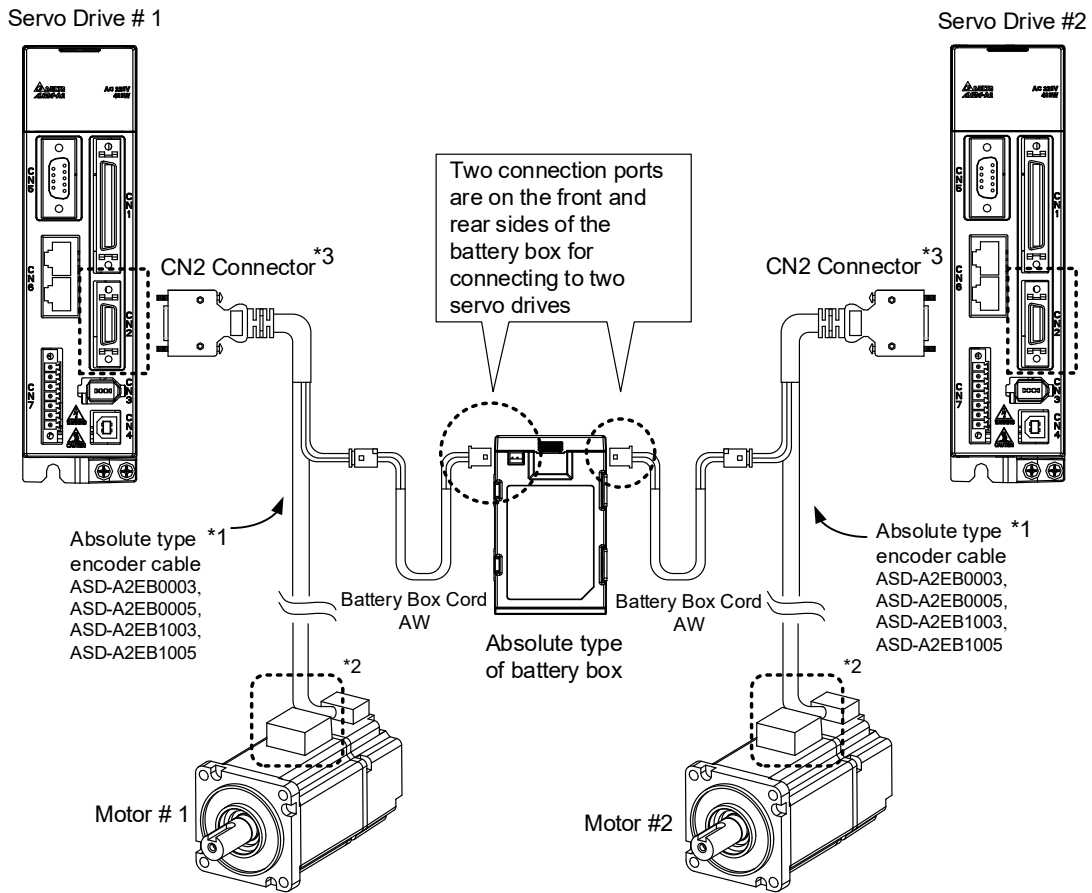

Note:

This is the wiring diagram for connecting to a single battery box. The scale of the objects does not match the dimensions as shown in the drawing above. For different models of AC servo drives and motors, the connection cables may differ.

For 1* and 2*, please refer to section 12.1.3.

3* Definition of CN2 connector

Please conduct the wiring according to the following instructions. Wrong wiring might cause battery explosion.

Pin No.	CN2 Connector		Motor Connector	
	Terminal Symbol	Function and Description	Military Connector	Quick Connector
5	T+	Serial communication signal input/output (+)	A	1
4	T-	Serial communication signal input/output (-)	B	4
7	BAT+	Battery 3.6V	C	2
9	BAT-	Battery ground	D	5
14, 16	+5V	Power +5V	S	7
13, 15	GND	Power ground	R	8
-	Shield	Shield	L	9

Dual Battery Box (Connect to CN8)

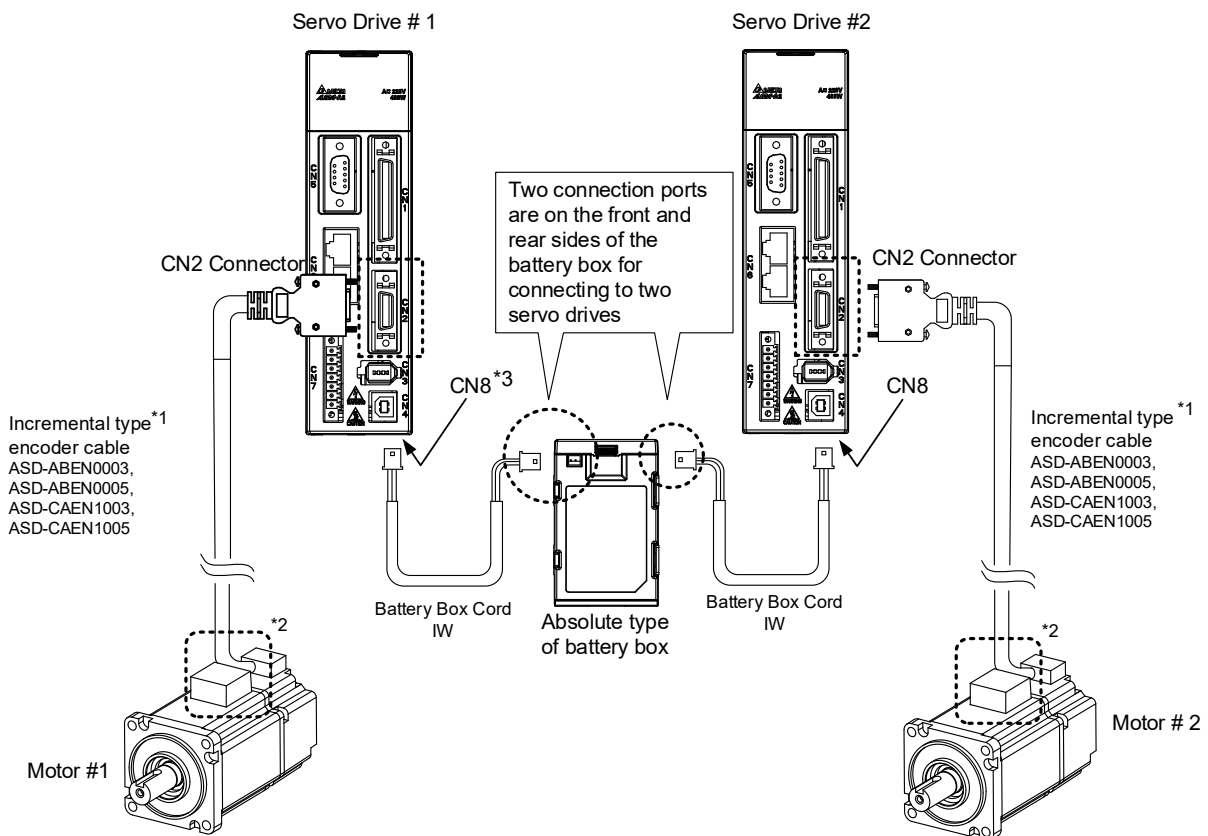

Note:

This is the wiring diagram for connecting to a single battery box. The scale of the objects does not match the dimensions as shown in the drawing above. For different models of AC servo drives and motors, the connection cables may differ.

For 1* and 2*, please refer to section 12.1.3.

3* Definition of CN8 connector

Please conduct the wiring according to the following instructions. Wrong wiring might cause battery explosion.

Pin No.	Terminal Symbol
1	BAT+
2	BAT-

12.2.2 How to Install a Battery

Single Battery Box

Loosen the latches of both sides to open the top cover.

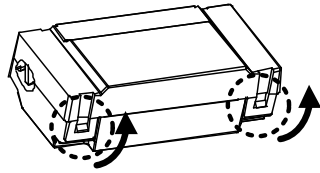

Put on the clip on the cable. Please note that the position of the clip should be very close to the heat shrink tube.

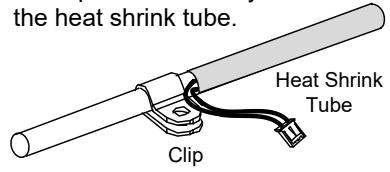

- ① Plug in the connection cable
- ② Turn the screw to tighten it.

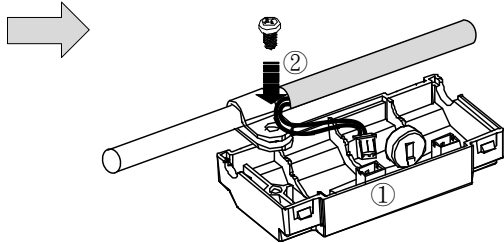

Install a new battery.

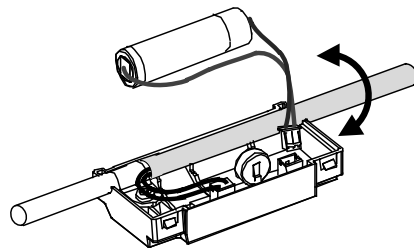

Place the cables into the box and put the cover on the box.

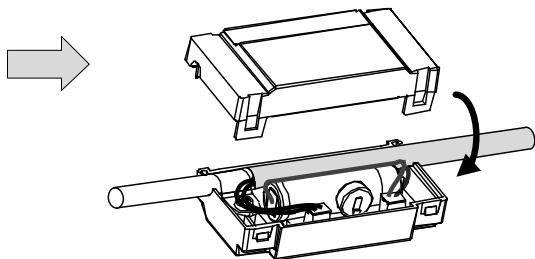

Dual Battery Box

Pull the latches located on the bottom side as shown in the figure below.

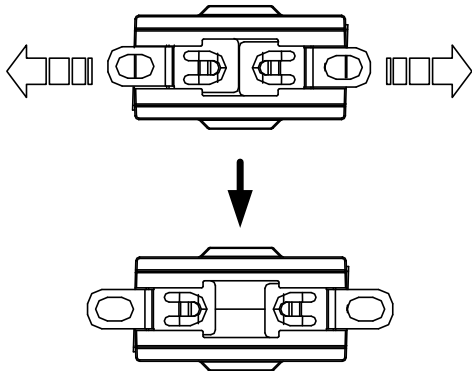

Tighten the mounting screws to secure the battery box.

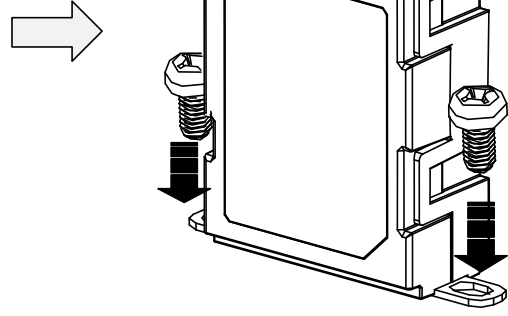

12.2.3 How to Replace a Battery

Please replace with a new battery if AL061 occurs, it means the battery is under voltage (refer to section 12.7.1 for detailed description). Or when accessing P0-02 for showing the battery power and it displays 31, which means the voltage is under 3.1V, so as to avoid data loss.

When the voltage is under 2.7V, it might lose the record of motor's position. Please conduct homing after replacing with a new battery. Please refer to section 12.7.1 for detailed description.

Please replace the battery while the power is applied to the servo drive in order to prevent the absolute position data loss.

Single Battery Box

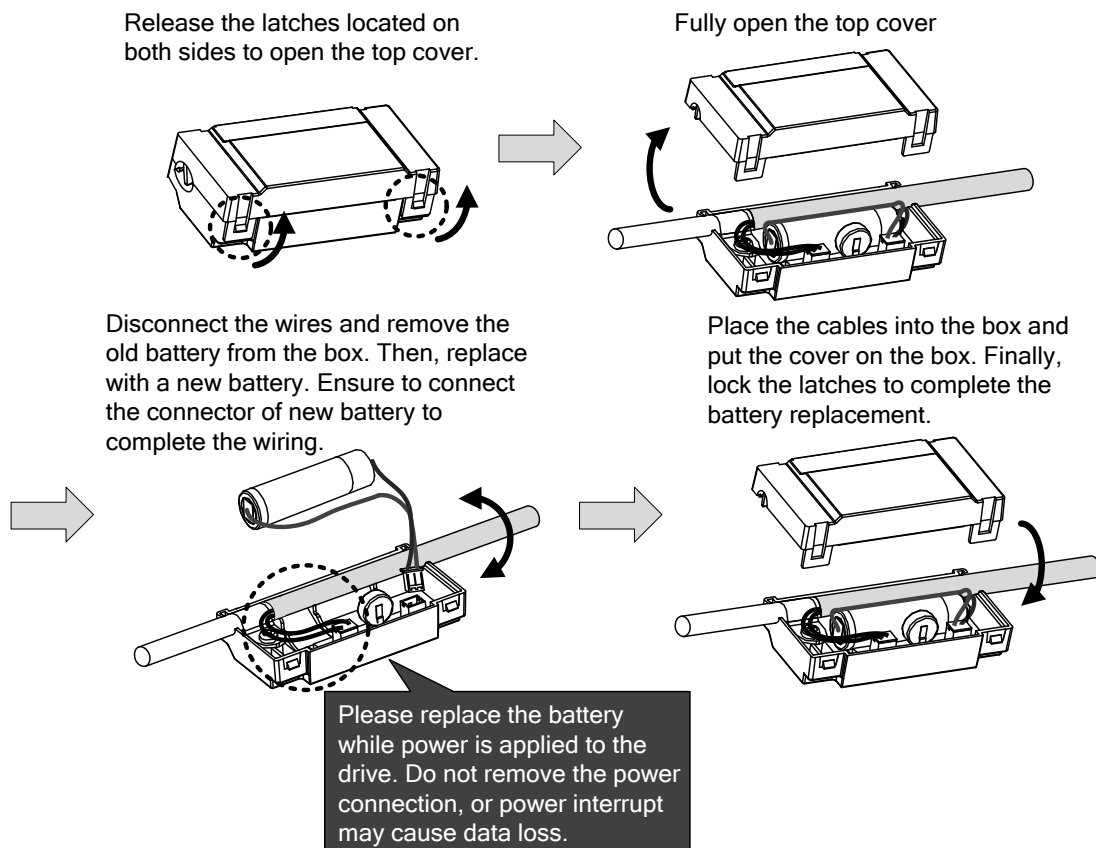

Dual Battery Box

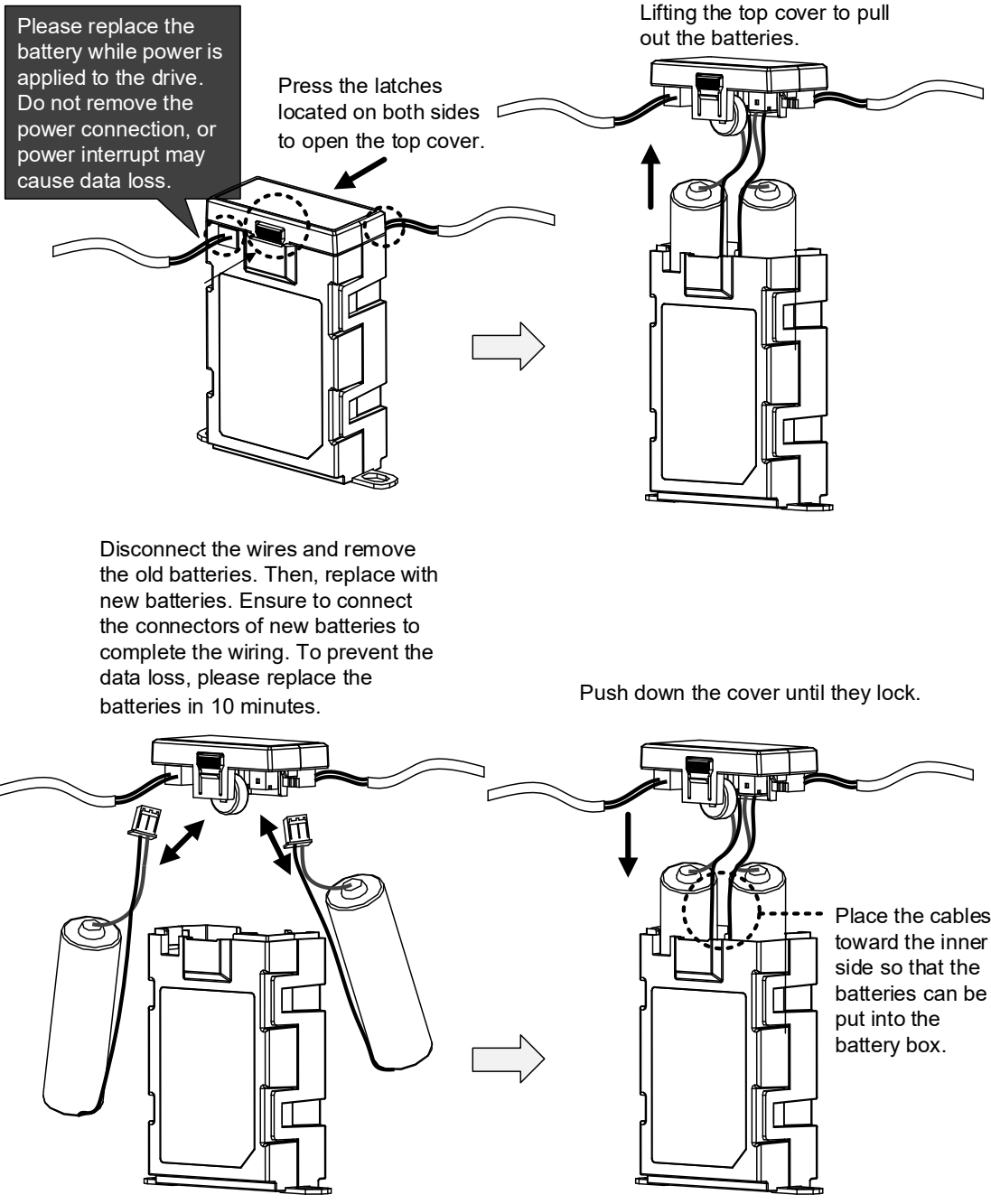

12.3 System Initialization Procedure and Operation

12.3.1 System Initialization Procedure

When the servo system is power on, the host controller can get the motor coordinate position via communication with RS-485 or DI/O. There are two data in different units can be read, and they are in PULSE and PUU.

At the very first time to operate absolute system, there will be a fault code, AL060 shown when power on because the initialization procedure still not yet be done. The fault will be kept until the initialization procedure is finished. Besides, the AL060 will be displayed when the power from the servo and battery is discontinued that will lead to the coordinate system lost. There is a fault code, AL062 which is used to indicate when the number of motor rotations is exceeding the range -32768 to 32767. But from the view of PUU, the coordinate value must fall into the range -2147483648 to 2147483647 to avoid triggering the fault AL289.

Except for the alarms mentioned above, you can use P2-70 to set up Delta's absolute servo system. You can choose not to show AL062 and AL289 if overflow occurs in the absolute coordinate system when the number of rotations exceeds the range -2147483648 to 2147483647. This is for the applications that the motor rotates in a single direction with incremental commands.

Parameter Settings:

1. The AL060 will be cleared when the coordinate system has been initialized.

PR mode: The absolute coordinate system will be reset after any homing operation under PR mode.

Other modes: Two methods can be used to initialize the coordinated system. One is via digital inputs described in section 12.3.4, and the other is applying parameters in section 12.3.5.

2. For an initialized system when the power is turned on, the host controller can read the absolute coordinate data via digital inputs and digital outputs (see section 12.3.6) or parameters with communication (see section 12.2.6). Through the settings of parameter P2-70, you can have the host controller to read the value in either PUU (see section 12.3.3) or the pulse number within one turn 1280000 (see section 12.3.2).

12.3.2 Pulse Counting

When the motor is running in clockwise direction, the counting number of turns will be minus where the counter clockwise rotating is plus. The number range for turns is from -32768 to 32767. The fault code, AL062, will appear when exceeding this counting range and it can be cleared by resetting the coordinate system. If parameter P2-70 has been set to ignore the over range alarming, the AL062 is disabled even exceeding the counting range. For the counter clockwise counting, the sequence of the number is ...32767, -32768, -32767, -32766 and the clockwise will have a sequence like ...-32768, 23767, 32766

In addition, there are 1280000 pulses (0 ~ 1279999) in one rotation. Please pay attention on its direction. The communication or digital inputs/digital outputs can be used to read it.

Pulse number for the distance = m (turn) × 1280000 + pulse number within one turn (0 ~ 1279999)

The conversion between Pulse and PUU:

When the rotating direction is CCW defined in P1-01.

$$\text{PUU number} = \text{pulse number} \times \frac{(P1-45)}{(P1-44)} + (P6-01)$$

When the rotating direction is CW defined in P1-01.

$$\text{PUU number} = (-1) \times \text{pulse number} \times \frac{(P1-45)}{(P1-44)} + (P6-01)$$

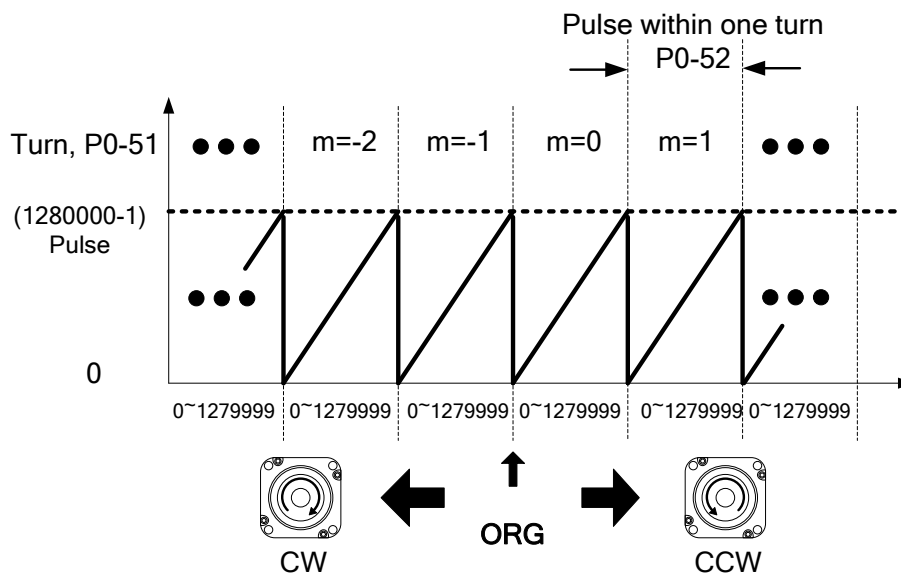

Figure 12.1 Pulse counting in absolute coordinate system

12.3.3 PUU Counting

A 32-bit number with sign is used to denote PUU number in an absolute system. The PUU number is increasing when the motor is in positive rotating direction and decreasing for a negative running direction. The motor's rotating direction is defined in P1-01 Z setting. In a word, the encoder feedback number is an easy way to distinguish the motor's rotating direction. Increasing number sequence is for positive direction and decreasing number sequence is for negative direction.

If the motor keeps rotating in one direction, the AL062 will be shown when exceeding the number range -32768 to 32767 for turns, and the AL289 is for PUU out of the range -2147483648 to 22147483647. Both of these fault codes can be cleared by homing.

And the parameter P2-70 can be used to take the range restrictions away in order to avoid occurring AL062 and AL289. When the counting number reaches the maximum number, the PUU pulse number sequence for forward rotation is ... 2147483647, -2147483648, -2147483647... where the number sequence -2147483648, 2147483647, 2147483646... is for reverse rotation. Two examples for evaluating the timing of overflow are as below:

Example 1:

When P1-44=128 and P1-45=10, there are 100000 PUU for motor to rotate one turn. $2147483647 \div 100000 \approx 21474.8$. The limit to trigger the fault AL289 is 21474.8 (< 32767).

Example 2:

When P1-44=128 and P1-45=1, there are 10000 PUU for motor to rotate one turn. $2147483647 \div 10000 \approx 214748.3$. The limit to trigger the fault AL062 is 32767 (< 214748.3).

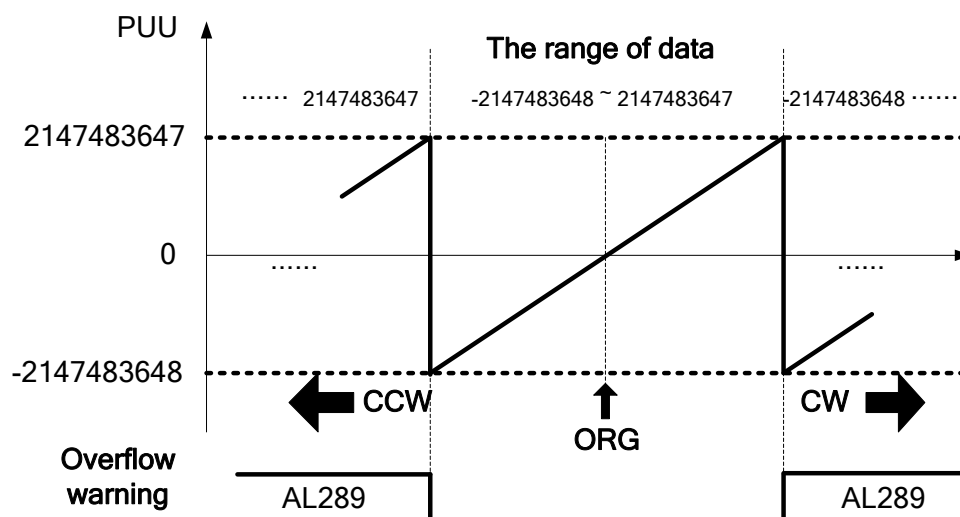
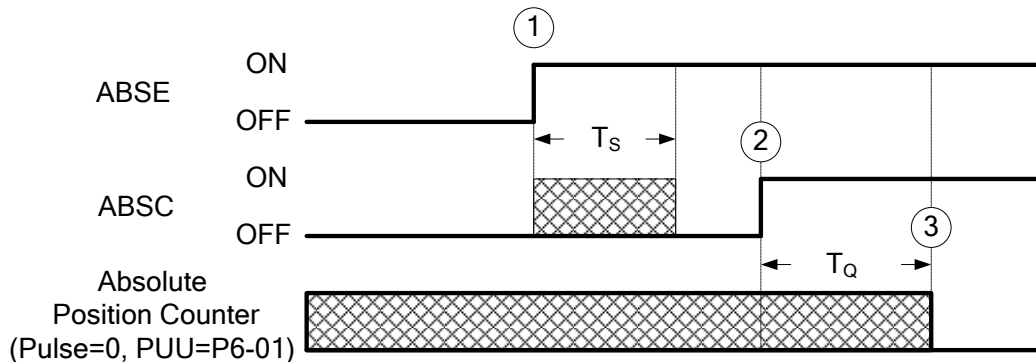

Figure 12.2 PUU counting in absolute coordinate system

Note: When an absolute system has been initialized, if the parameter P1-01 Z setting, P1-44, and P1-45 are changed, the absolute coordinate system will be destroyed. A homing procedure is necessary at that moment.

12.3.4 Use Digital Inputs/Outputs to Create the Absolute Origin Coordinate

When the servo drive is in PR mode, initialize the system with PR homing. Except for PR mode, the digital inputs and outputs can be used for a driver to do homing when other modes are selected. Move the motor to home place, enable digital input, ABSE, then enable digital input, ABSC from OFF to ON, and the system will start to initialization. The pulse number will be set to zero and the number in P6-01 is for PUU to reference. Please refer to Figure 12.3 below for the signal controlling chart.



	T_S (ms)	T_Q (ms)
Min.	P2-09+2	
Max.	P2-09+250	

Figure 12.3 The controlling chart for creating the absolute origin coordinates via digital inputs/outputs

The descriptions for the timing:

1. When the host controller switches ABSE from OFF to ON, the system needs to wait after a period of time T_S before proceeding to the next steps to reset.
2. After waiting time T_S , the host controller now can enable the ABSC from OFF to ON and hold the signal for T_Q to reset the coordinate system where pulse number will be zero and PUU number is defined in P6-01.

12.3.5 Use Parameters to Create the Absolute Origin Coordinate

When the parameter P2-71 is set to 1 (one) via the keypad or communication, the system starts to create the absolute origin coordinate. Because P2-71 is write-protected by P2-08, you need to first set 271 to P2-08 to write the value to P2-71. The procedure is P2-08=271 and then P2-71=1. This mode is only for all modes except PR mode. If it is in PR mode, please execute homing procedure to create the absolute origin coordinate.

12.3.6 Use Digital Inputs/Outputs to Read the Absolute Coordinate Data

When Bit 0 is 0 in P2-70, the PUU number can be read by using digital inputs and outputs.

The frame is as below.

Bit 79 ~ Bit 64	Bit 63 ~ Bit 32	Bit 31 ~ Bit 16	Bit 15 ~ Bit 0
Check Sum	Encoder PUU -2147483648 - 2147483647	0	Encoder status, P0-50

When Bit 0 is 1 in P2-70, the PULSE number can be read by using digital inputs and outputs.

The frame is as below.

Bit 79 ~ Bit 64	Bit 63 ~ Bit 32	Bit 31 ~ Bit 16	Bit 15 ~ Bit 0
Check Sum	Pulse within one turn 0 ~ 1279999 (= 1280000-1)	Encoder turn -32768 ~ +32767	Encoder status, P0-50

Explanation:

Check Sum = ((((((WORD_0+0xA700) XOR WORD_1)+0x605A) XOR WORD_2)+0x30A5) XOR WORD_3)+0x5A06)

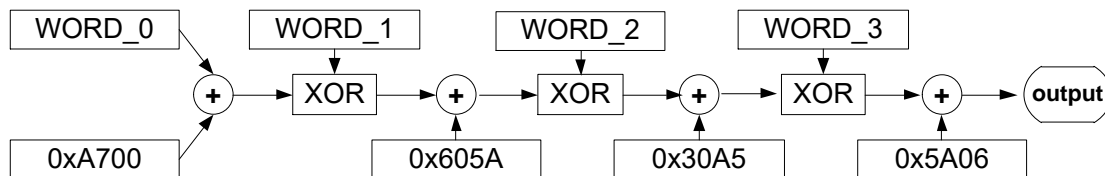

Note:

1. This algorithm has no plus or minus sign.
2. 0xA700, 0x605A, 0x30A5, and 0x5A06 are the constants of hexadecimal.
3. WORD_0: encoder status (Bit 15 ~ 0)
 WORD_1: encoder turn (Bit 31 ~ 16)
 WORD_2: encoder pulse (Bit 47 ~ 32)
 WORD_3: encoder pulse (Bit 63 ~ 48)

The setting in P2-70 with digital inputs/outputs communication can be used to read PULSE number or PUU data with below signal communication sequence.

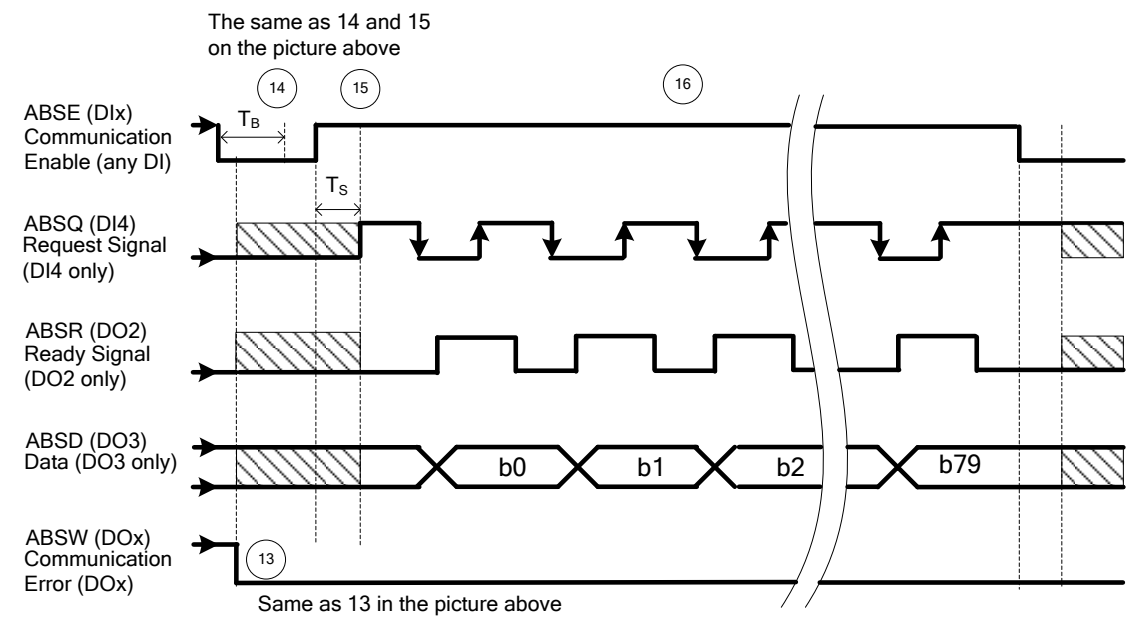
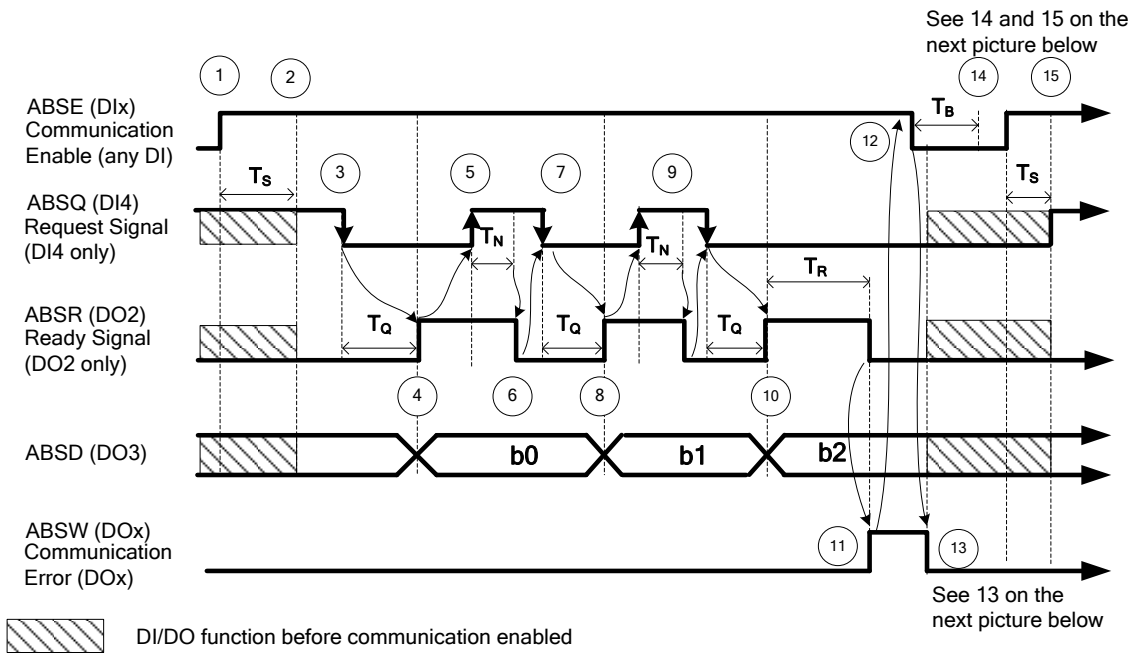

	$T_R(ms)$	$T_S(ms)$	$T_Q(ms)$	$T_N(ms)$	$T_B(ms)$
Min	-	P2-09+2			
Max	200	P2-09+10			

Figure 12.4 Timing diagram of using digital inputs/outputs to read absolute data

The step explanation for the communication:

1. At the very beginning of communication, the host controller must enable ABSE and all the communication starts from here.
2. After the signal has been recognized, the DI4, DO2, and DO3 (no matter what their functions are), will be switched to the functions of ABSQ, ABSR, and ABSD respectively. At the moment of the communication function enabled, if the signal of ABSQ is in high level, it will keep high level for its original function and also will be high level signal for ABSQ. DI4, DO2, and DO3 are multiple functions pins, please be noted especially at the moment of communication function switching on and off. For the purpose of simplifying the application, the functions of these three digital inputs and outputs could be set to 0 for communication use only.
3. When ABSE is at high level and retaining T_S long, the function of DI4 will be switched to ABSQ. If the host controller switch ABSQ to low after it is defined, the servo drive will recognize that host controller wants to read data from it.
4. After confirming time T_Q , the data for communication is already well prepared on ABSD and the signal ABSR is enabled for signaling the host controller to get data from the servo drive side. If the longest possible waiting time of T_Q (see Figure 12.4) expired, the host controller still cannot get the signal ABSR from low to high which could be a problem of wiring disconnection.
5. After the host controller detects that ABSR is high, the data is fetched. The ABSQ will be set to signal high to inform the drive after data read.
6. After confirming time T_N for ABSQ kept high, the servo drive will maintain ABSR to low for signaling the host controller to be ready for accessing next bit.
7. The host will set ABSQ to low when it detects that ABSR is low for requesting the next bit from drive.
8. The servo drive will repeat the steps 3 to 4 to put its data at ABSD for next bit communication
9. By repeating steps 5 to 7, the host controller will get the data, bit, and have an acknowledgement to the servo drive.
10. The third bit data is ready on the servo drive side.
11. After the data is ready and has been held for time T_R , the servo drive still does not see the signal ABSQ controlled by the host controller, and then the servo drive will have a communication error flag ABSW raise to terminate the communication procedure.
12. The host controller will set the ABSE to low for restart the communication cycle after getting the communication error message from the servo drive.
13. The communication error flag on servo drive side will be reset after detecting a low signal ABSE from the host controller.
14. A new communication cycle on the host controller restarts after the buffering time T_B .
15. Repeat the step 1 for the host controller to start a new communication cycle.
16. If no error occurs during communication, the host controller finishes the data transmission for

bit 0 to bit 79 (80 bits in total), the functions of DI4, DO2, and DO3 resume their original functions after the communication is complete.

Note:

If ABSW does not go back to high level signal after the changing of ABSE for signal low to high that is a sign of error occurring, there must be some other errors existing. Please check if the coordinate data still there, the voltage level of battery, or overflowing on the coordinate value. A new communication cycle can be started only all of these errors been removed.

12.3.7 Use Parameter to Read the Absolute Coordinate Data

The servo drive will update its encoder status to P0-50 and encoder position to P0-51 and P0-52 when the parameter P0-49 is set. The Bit 1 of P2-70 is used to select which type of the data will be read, PULSE or PUU. While the servo motor is stalling, it is always maintaining its position with a very tiny forward and backward movement. At the moment the encoder data read, the coordinate data in servo drive side will be reset to the current position of motor if P0-49=2 where it is just read without changing any from the servo motor when P0-49=1. For example, if the motor is positioning at the place of 20000, it will move around position from 19999 to 20001 normally. The command for reading the encoder data is put when the motor is at the place 20001, and the data 20001 will be read and the coordinate data in servo drive will be revised to 20001. There will avoid the error from the data at encoder side and the data at drive side. The P0-49 will be reset to 0 when all the encoder data put in P0-50 to P0-52 is ready, and it means that the host controller can get the data now. When the status already signals absolute coordinate data lost or overflow of number for turns in P0-50, the values in P0-51 to P0-52 are not correct. A homing or system reset procedure is necessary now.

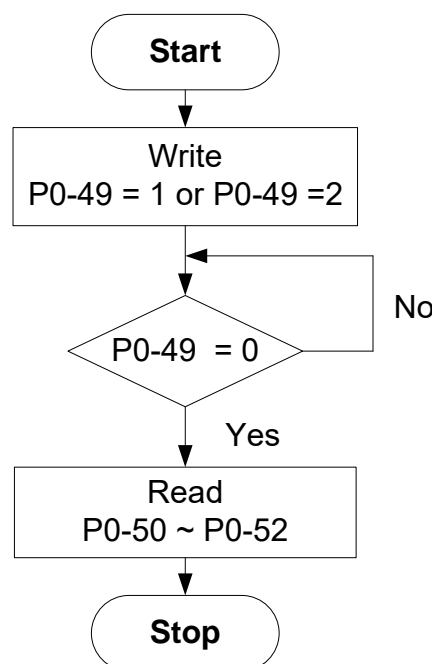

12.4 Related Parameters for Absolute System

P2-69●	ABS	Absolute Encoder Setting	Address: 028AH 028BH
Operational Interface :	Panel / Software	Communication	Related Section: N/A
Default :	0x0		
Control Mode :	ALL		
Unit :	N/A		
Range :	0x0 ~ 0x1		
Data Size :	16-bit		
Format :	Hexadecimal		

Settings : 0: Incremental mode. Servo motor with absolute encoder can be operated as incremental motor.

1: Absolute mode. (This setting is only available for the servo motor with absolute encoder. When an incremental servo motor is connected, if P2-69 is set to 1, AL069 will occur.)

Note: This parameter is effective only after the servo drive is re-powered on.

P2-70	MRS	Read Data Format Selection	Address: 028CH 028DH
Operational Interface :	Panel / Software	Communication	Related Section: N/A
Default :	0x0		
Control Mode :	ALL		
Unit :	N/A		
Range :	0x00 ~ 0x07		
Data Size :	16-bit		
Format :	Hexadecimal		

Settings :

Bit 7	Bit 6	Bit 5	Bit 4	Bit 3	Bit 2	Bit 1	Bit 0
-------	-------	-------	-------	-------	-------	-------	-------

Bit 15	Bit 14	Bit 13	Bit 12	Bit 11	Bit 10	Bit 9	Bit 8
--------	--------	--------	--------	--------	--------	-------	-------

Bit 0: Data unit setting of digital input/output (DI/DO);

1: Pulse, 0: PUU

Bit 1: Communication data unit setting; 1: Pulse, 0: PUU

Bit 2: Overflow warning; 1: No overflow warning, 0: Overflow warning, AL289 (PUU), AL062 (pulse).

Bit 3 ~ Bit 15: Reserved. Must be set to 0.

P2-71	CAP	Absolute Position Homing		Address: 028EH 028FH
Operational Interface :	Panel / Software	Communication		Related Section: N/A
Default :	0x0			
Control Mode :	ALL			
Unit :	N/A			
Range :	0x0 ~ 0x1			
Data Size :	16-bit			
Format :	Hexadecimal			

Settings : When P2-71 is set to 1, the current position will be set as home position. This function is the same as the digital input, ABSC. This function can be enabled only when parameter P2-08 is set to 271.

P0-49	UAP	Renew Encoder Absolute Position		Address: 0062H 0063H
Operational Interface :	Panel / Software	Communication		Related Section: N/A
Default :	0x0			
Control Mode :	ALL			
Unit :	N/A			
Range :	0x00 ~ 0x02			
Data Size :	16-bit			
Format :	Hexadecimal			

Settings : This parameter is used to renew the absolute position data of the encoder.



Parameter Renew Setting:

1: Renew the encoder data to parameters P0-50 ~ P0-52 only.

2: Renew the parameters P0-50 ~ P0-52, and clear the position error as well. While this setting is activated, the current position of the motor will be reset as the target position of position command (same function as CCLR).

P0-50★	APSTS	Absolute Coordinate System Status		Address: 0064H 0065H
	Operational Interface :	Panel / Software	Communication	Related Section: N/A
	Default :	0x0		
	Control Mode :	ALL		
	Unit :	N/A		
	Range :	0x00 ~ 0x1F		
	Data Size :	16-bit		
	Format :	Hexadecimal		

Settings :

Bit7	Bit6	Bit5	Bit4	Bit3	Bit2	Bit1	Bit0
------	------	------	------	------	------	------	------

Bit15	Bit14	Bit13	Bit12	Bit11	Bit10	Bit9	Bit8
-------	-------	-------	-------	-------	-------	------	------

Bit0: Absolute position status

Bit0=0: Normal

Bit0=1: Absolute position is lost

Bit1: Voltage level of battery

Bit0=0: Normal

Bit0=1: Low battery

Bit2: Status of encoder multiturn

Bit0=0: Normal

Bit0=1: Overflow

Bit3: Status of PUU

Bit0=0: Normal

Bit0=1: Overflow

Bit4: Absolute coordinate system status

Bit0=0: Normal

Bit0=1: Absolute coordinate system has not been set

Bit5 ~ Bit15: Reserved. Must be set to 0.

P0-51★

APR	Encoder Absolute Position (Multiturn)		Address: 0066H 0067H
Operational Interface :	Panel / Software	Communication	Related Section: N/A
Default :	0x0		
Control Mode :	ALL		
Unit :	rev		
Range :	-32768 ~ +32767		
Data Size :	32-bit		
Format :	Decimal		

Settings : While the Bit 1 of P2-70 is set to 1 to read the encoder pulse number, this parameter represents the turns of encoder absolute position. While the Bit 1 of P2-70 is set to 0 to read the PUU number, this parameter becomes disabled and the setting value of this parameter is 0.

P0-52★

APP	Encoder Absolute Position (Pulse number within Singleturn or PUU)		Address: 0068H 0069H
Operational Interface :	Panel / Software	Communication	Related Section: N/A
Default :	0x0		
Control Mode :	ALL		
Unit :	Pulse or PUU		
Range :	0~1280000-1 (Pulse Number); -2147483648 ~ 2147483647 (PUU)		
Data Size :	32-bit		
Format :	Decimal		

Settings : While the Bit 1 of P2-70 is set to 1 to read the pulse number, this parameter represents the pulse number of encoder absolute position. While the Bit 1 of P2-70 is set to 0 to read the PUU number, this parameter represents PUU number of motor absolute position.

P0-02	STS	Drive Status		Address: 0004H 0005H
	Operational Interface :	Panel / Software	Communication	Related Section: 7.2
Default :	00			
Control Mode :	ALL			
Unit :	-			
Range :	00 ~ 127			
Data Size :	16-bit			
Format :	Decimal			

Settings : Please refer to section 7.2.1 for the description of monitoring variables.

12.5 Digital Input (DI) Function Definition (for Absolute System)

Setting Value: 0x1D			
DI Name	Function Description of Digital Input (DI)	Trigger Method	Control Mode
ABSE	<p>When DI.ABSE is ON, it is in ABS mode. DI.ABSQ, DI.ABSC, DI.ABSR, DI.ABSD and DI.ABSC are enabled. Please refer to Diagrams 12.3 and 12.4 for detailed description.</p> <p>When DI.ABSE is ON, the function of DI4, DO2, and DO3 will be disabled. Function of DI4 will be ASDQ, DO2 will be ABSR and DO3 will be ABSD.</p> <p>DI pins of DI.ABSC can be assigned by parameters.</p> <p>When DI.ABSE is on, P2-13 cannot be modified.</p>	Level Triggered	ALL

Setting Value: When DI.ABSE is ON, DI4 inputs ABSQ signal, function set by P2-13 is disabled.			
DI Name	Function Description of Digital Input (DI)	Trigger Method	Control Mode
ABSQ is always input by DI4	During I/O transmission, Handshaking signal will be sent to the servo drive by the controller. When DI.ABSQ is OFF, it means the controller issues Request ; DI.ABSQ is ON means the controller has already received ABSD signal. When DI.ABSE is ON, this DI is enabled. Please refer to diagram 12.4 for detailed description.	Rising / Falling-edged Triggered	ALL

Setting Value: 0x1F			
DI Name	Function Description of Digital Input (DI)	Trigger Method	Control Mode
ABSC	When DI.ABSC is ON, multi-turn data stored in absolute encoder will be set to 0 and PUU number will be the value of P6-01. When DI.ABSE is ON, this function is enabled. Please refer to diagram 12.3 for detailed description.	Rising-edge Triggered	ALL

12.6 Digital Output (DO) Function Definition (for Absolute System)

Setting Value: When DI.ABSE is ON, DO2 outputs ABSR signal, function set by P2-19 is disabled.			
DO Name	Function Description of Digital Output (DO)	Trigger Method	Control Mode
ABSR is always output by DO2	DO.ABSR is OFF means the Request sent by ABSQ has been received. DO.ABSR is ON means the data that is outputted by ABSD is valid so that the controller can access the ABSD data. This output is only valid when DI.ABSE is ON. Please refer to diagram 12.4 for detailed description.	Level Triggered	ALL

Setting Value: When DI.ABSE is ON, DO3 outputs ABSD signal, function set by P2-20 is disabled.			
DO Name	Function Description of Digital Output (DO)	Trigger Method	Control Mode
ABSD is always output by DO3	DO pin of ABS data. The data is valid when ABSR is ON. This output is only valid when DI.ABSE is ON. Please refer to diagram 12.4 for detailed description.	Level Triggered	ALL

Setting Value : 0x0D			
DO Name	Function Description of Digital Output (DO)	Trigger Method	Control Mode
ABSW	Display the absolute encoder alarms. Please refer to diagram 12.4 for detailed description	Level Triggered	ALL

12.7 Alarms for Absolute System

Display	Alarm Name	Alarm Description
AL028	Encoder voltage error or the internal of the encoder is in error	Charging circuit of the servo drive is not removed and the battery voltage is higher than the specification (>3.8 V) or the encoder signal is in error.
AL029	Gray code error	Absolute position is in error.
AL034	Internal communication of the encoder is in error	<ol style="list-style-type: none"> 1. Internal communication error of the absolute encoder 2. Internal error of other type of encoder
AL060	The absolute position is lost	Due to battery under voltage or the failure of power supply, the encoder lost the internal record.
AL061	Encoder under voltage	The voltage of the absolute encoder is lower than the specification, or voltage of the battery is in error.
AL062	The multi-turn of absolute encoder overflows	The multi-turn of absolute encoder exceeds the maximum range: -32768 ~ +32767
AL068	Absolute data transmitted via I/O is in error	The sequence is wrong when reading the absolute position via DI/O.
AL069	Wrong motor type	Incremental motor is not allowed to activate the absolute function.
AL289	Feedback position counter overflows	Feedback position counter overflows.

12.7.1 Causes and Corrective Actions

AL028: Encoder voltage error or the internal of the encoder is in error

Causes	Checking Method	Corrective Actions
Battery voltage is too high	<ol style="list-style-type: none"> 1. Check if the charging circuit exists in the servo drive. 2. Check if the battery is correctly installed (voltage > 3.8V) 	According to the procedure of Over voltage to check. When corrective actions are done, AL028 will be cleared automatically.
The internal encoder is in error.	<ol style="list-style-type: none"> 1. Check if it is the absolute type encoder. 2. Check if the servo is properly grounded. 3. Check if the encoder cable separates from the power supply or the high-current circuit to avoid the interference. 4. Check if the shielding cables are used in the wiring of the encoder. 	<ol style="list-style-type: none"> 1. If the situation is not improving, please send the drive back to the distributors or contact with Delta. 2. Please connect the UVW connector (color green) to the heat sink of the servo drive. 3. Please check if the encoder cable separates from the power supply or the high-current circuit. 4. Please use shielding mesh. If the situation is not improving, please send the drive back to the distributors or contact with Delta.

AL029: Gray code error

Causes	Checking Method	Corrective Actions
Absolute position is in error	Re-power on to operate the motor and check if the alarm will occur again.	If the alarm occurs again, please change the encoder.

AL034 : Internal communication of the encoder is in error

Causes	Checking Method	Corrective Actions
Internal communication of the encoder is in error	<ol style="list-style-type: none"> 1. Internal communication error of the absolute encoder 2. Internal error of other type of encoder 3. Incorrect battery wiring. 4. Check the wiring. 5. Check the voltage. 	Conduct the wiring of the battery again and then cycle power on the system.

AL060: Absolute position lost

Causes	Checking Method	Corrective Actions
Battery under voltage	Check if the voltage of the battery is lower than 2.8V.	After changing the battery, conduct homing procedure again. Please refer to the description of creating absolute origin coordinate in sections 12.3.4 and 12.3.5.

Causes	Checking Method	Corrective Actions
Change the battery when the drives' main power is OFF.	Do not change or remove the battery when the drive's main power is OFF.	Conduct the homing procedure again. Refer to Chapter 12 for the description of creating absolute origin coordinate.
After activating the absolute function, the absolute origin coordinate has not been created.	<ol style="list-style-type: none"> 1. Install the battery. 2. Check the wiring between the battery pack and the power cable of the servo drive. 3. Check the wiring of the encoder. 	Conduct homing procedure. Please refer to the description of creating absolute origin coordinate in sections 12.3.4. and 12.3.5.
Bad connection of the battery power circuit	<ol style="list-style-type: none"> 1. Check the wiring of the encoder. 2. Check the wiring between the battery pack and the power cable of the servo drive. 	Connect or repair the wiring of the battery so as to supply the power to the encoder. Conduct homing procedure again. Please refer to the description of creating absolute origin coordinate in sections 12.3.4. and 12.3.5.

AL061: Encoder under voltage

Causes	Checking Method	Corrective Actions
Battery under voltage	<ol style="list-style-type: none"> 1. Check if the voltage of the battery on the panel is lower than 3.1V (tentative specification). 2. Measure if the voltage of the battery is lower than 3.1V (tentative specification). 	Change the battery when the power is ON which is controlled by the servo drive. After you change the battery, AL061 will be cleared automatically.

AL062: The multi-turn of absolute encoder overflows

Potential Cause	Checking Method	Corrective Actions
The operation distance exceeds the range the absolute encoder is able to record.	Check if the operation distance exceeds the range, -32768 ~ +32767, the absolute encoder is able to record.	Conduct homing procedure again. Please refer to the description of absolute coordinate initialization in sections 12.3.4 and 12.3.5.

AL068: Absolute data transmitted via I/O is in error

Causes	Checking Method	Corrective Actions
Sequence error	<ol style="list-style-type: none"> 1. Switch OFF DI ABSQ should wait until DO ABSR is OFF. 2. Switch ON ABSQ should wait until DO ABSR is ON. 	Correct the reading sequence of I/O.
Reading time out	Check if the time between switching ON DO ABSR and switching ON ABSQ exceeds 200 ms.	After switching ON DO ABSR (the absolute position data is ready), read DO ABSD and switch ON DI ABSQ within 200 ms so as to inform the servo drive data reading is completed.

AL069: Wong motor type

Causes	Checking Method	Corrective Actions
Incremental motor is not allowed to activate the absolute function.	<ol style="list-style-type: none"> 1. Check if the motor is incremental or absolute encoder. 2. Check parameter P2-69. 	If the user desires to use absolute function, please choose absolute motor. If not, please set parameter P2-69 to 0.

AL289: Feedback position counter overflows

Causes	Checking Method	Corrective Actions
Feedback position counter overflows.	<ol style="list-style-type: none"> 1. Please set the gear ratio according to the total traveling distance of the absolute motor and the actual application requirements to avoid the overflow of feedback position counter. 2. If P2-69.Z is set to 1 (prevent index coordinate overflow function), please set P2-70 bit 2 to 1. 	NMT: Reset node or 0x6040.Fault Reset

12.8 Related Monitoring Variables

Code	Monitoring Variables / Attribute	Explanation
038 (26h)	Voltage level of battery	The voltage level of battery for an absolute encoder.

Appendix A Accessories

■ Power Connectors

Delta Part Number: ASDBCAPW0000 (for 220V series servo drive)

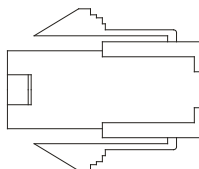

Delta Part Number: ASDBCAPW0100 (for 220V series servo drive, with brake contact)

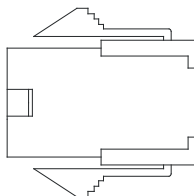

Delta Part Number: ASD-CAPW5400 (for 400V series servo drive)

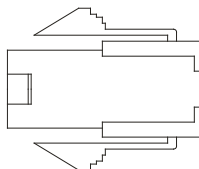

Delta Part Number: ASD-CAPW5100 (for 400V series servo drive, with brake contact)

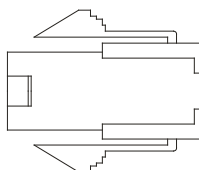

Delta Part Number: ASD-CAPW1000

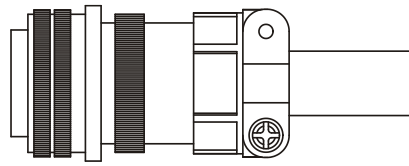

3106A-20-18S

Delta Part Number: ASD-CAPW2000

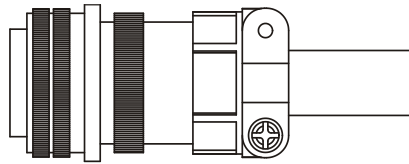

3106A-24-11S

Delta Part Number: ASD-CAPW4000

CLAMP: WPS3057-20A

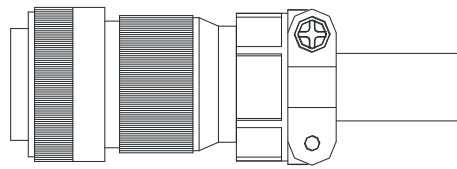
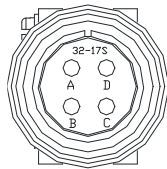

↖
Straight Plug WPS3106A-32-17S

Motor Brake Connector: ASD-CNBR1000

CLAMP: WPS3106A 10SL-4S-R

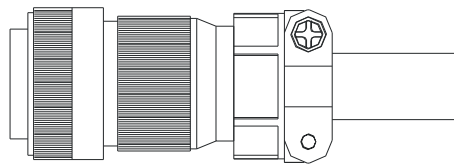
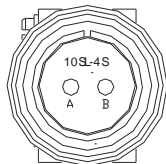

■ Power Cables

Delta Part Number: ASD-ABPW0003, ASD-ABPW0005 (for 220V series servo drive)

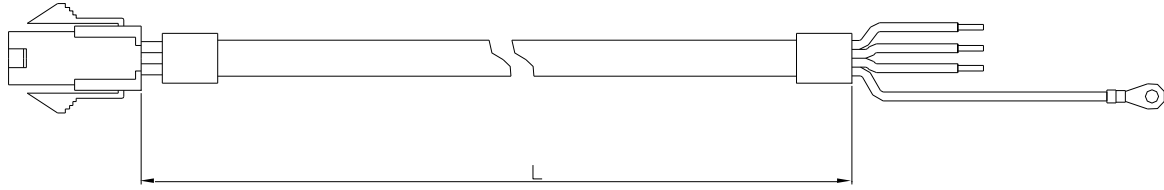

Title	Part No.	L	
		mm	inch
1	ASD-ABPW0003	3000 ± 100	118 ± 4
2	ASD-ABPW0005	5000 ± 100	197 ± 4

Delta Part Number: ASD-CAPW5403, ASD-CAPW5405 (for 400V series servo drive)

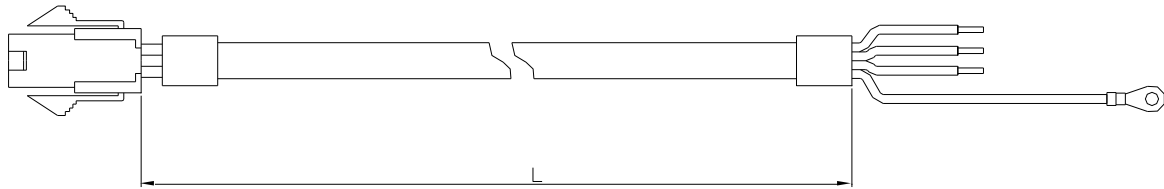

Title	Part No.	L	
		mm	inch
1	ASD-CAPW5403	3000 ± 100	118 ± 4
2	ASD-CAPW5405	5000 ± 100	197 ± 4

Delta Part Number: ASD-ABPW0103, ASD-ABPW0105
 (for 220V series servo drive, with brake cable)

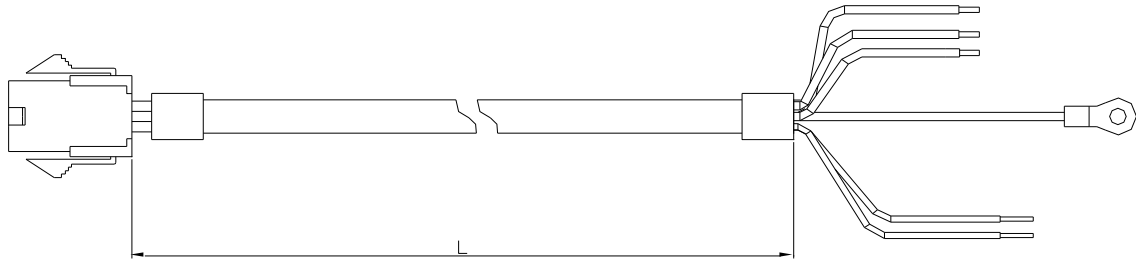

Title	Part No.	L	
		mm	inch
1	ASD- ABPW0103	3000 ± 100	118 ± 4
2	ASD- ABPW0105	5000 ± 100	197 ± 4

Delta Part Number: ASD-CAPW5103, ASD-CAPW5105
 (for 400V series servo drive, with brake cable)

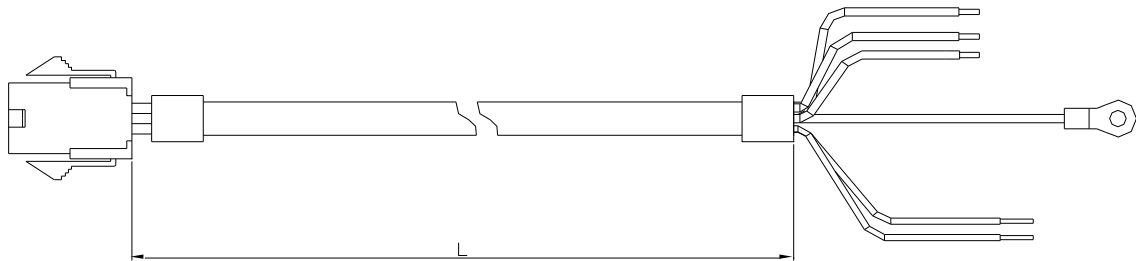

Title	Part No.	L	
		mm	inch
1	ASD- CAPW5103	3000 ± 100	118 ± 4
2	ASD- CAPW5105	5000 ± 100	197 ± 4

Delta Part Number: ASD-CAPW1003, ASD-CAPW1005

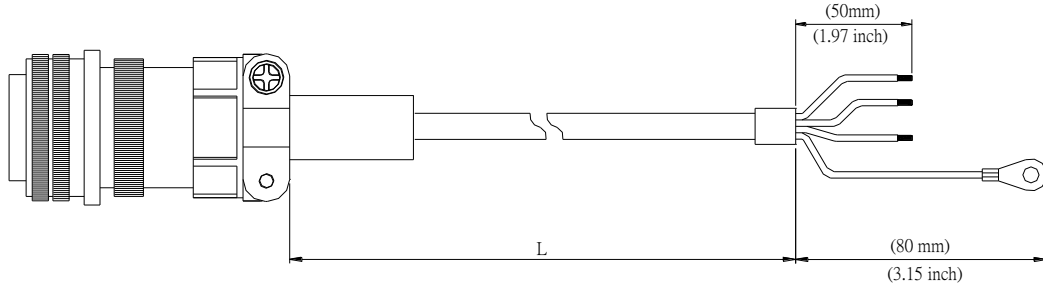

Title	Part No.	Straight	L	
			mm	inch
1	ASD-CAPW1003	3106A-20-18S	3000 ± 100	118 ± 4
2	ASD-CAPW1005	3106A-20-18S	5000 ± 100	197 ± 4

Delta Part Number: ASD-CAPW1103, ASD-CAPW1105

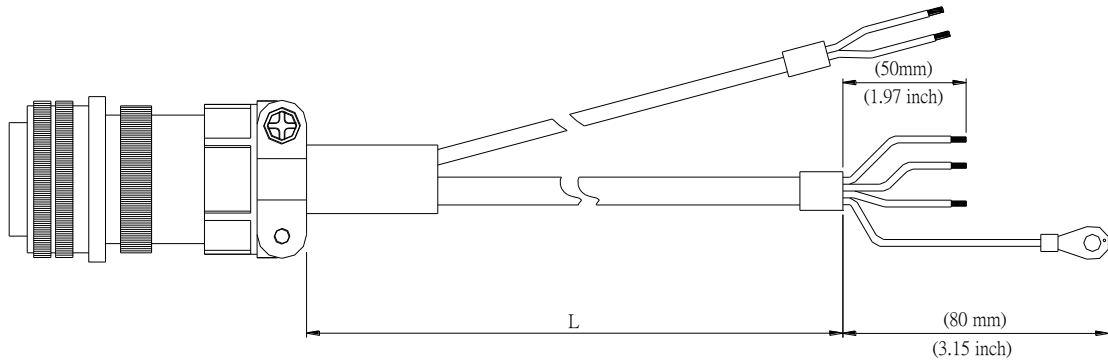

Title	Part No.	Straight	L	
			mm	inch
1	ASD-CAPW1103	3106A-20-18S	3000 ± 100	118 ± 4
2	ASD-CAPW1105	3106A-20-18S	5000 ± 100	197 ± 4

Delta Part Number: ASDB-CAPW1203, ASDB-CAPW1205

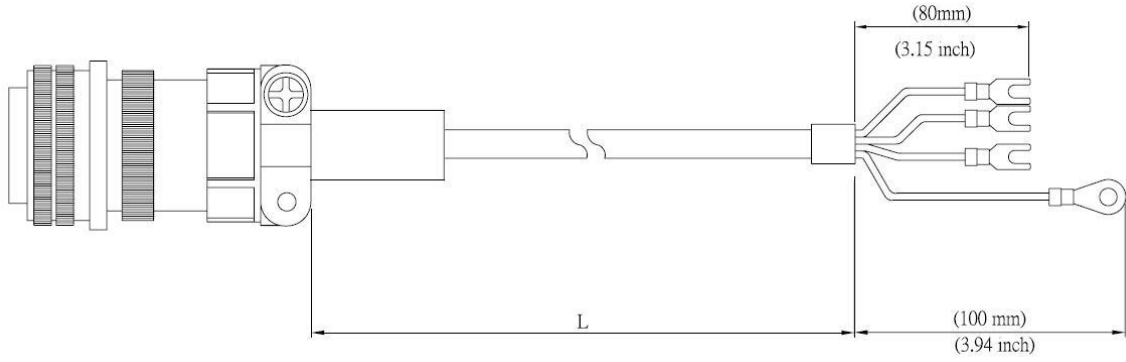

Title	Part No.	Straight	L	
			mm	inch
1	ASDB-CAPW1203	3106A-20-18S	3000 ± 100	118 ± 4
2	ASDB-CAPW1205	3106A-20-18S	5000 ± 100	197 ± 4

Delta Part Number: ASD-CAPW1303, ASD-CAPW1305

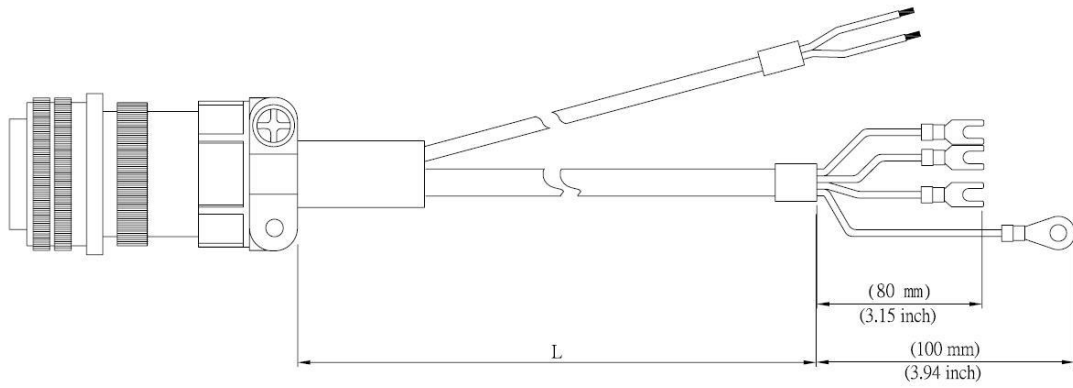

Title	Part No.	Straight	L	
			mm	inch
1	ASD-CAPW1303	3106A-20-18S	3000 ± 100	118 ± 4
2	ASD-CAPW1305	3106A-20-18S	5000 ± 100	197 ± 4

Delta Part Number: ASD-A2PW1003, ASD-A2PW1005

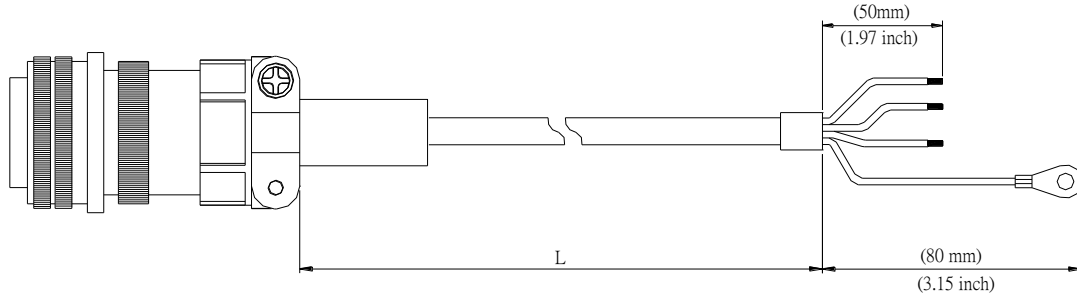

Title	Part No.	Straight	L	
			mm	inch
1	ASD-A2PW1003	3106A-20-18S	3000 ± 100	118 ± 4
2	ASD-A2PW1005	3106A-20-18S	5000 ± 100	197 ± 4

Delta Part Number: ASD-A2PW1103, ASD-A2PW1105

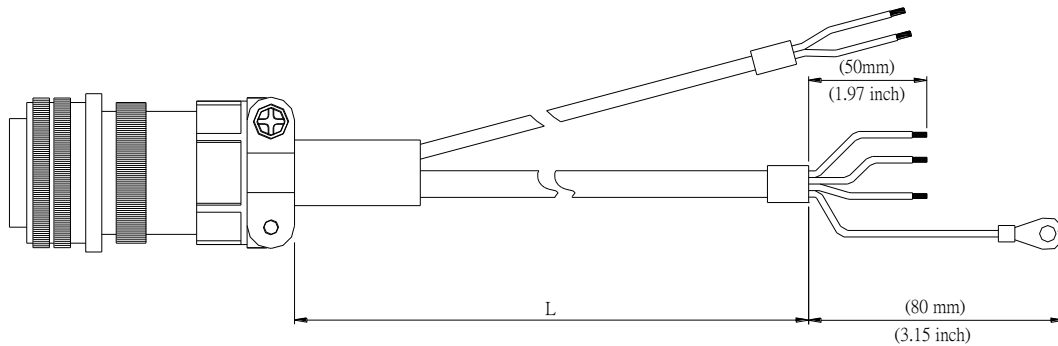

Title	Part No.	Straight	L	
			mm	inch
1	ASD-A2PW1103	3106A-20-18S	3000 ± 100	118 ± 4
2	ASD-A2PW1105	3106A-20-18S	5000 ± 100	197 ± 4

Delta Part Number: ASD-CAPW2003, ASD-CAPW2005

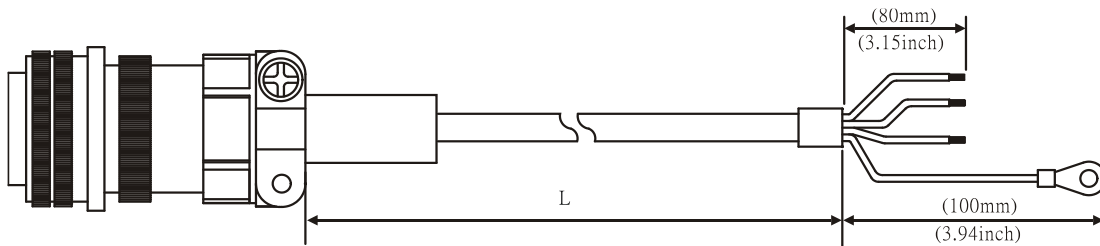

Title	Part No.	Straight	L	
			mm	inch
1	ASD-CAPW2003	3106A-24-11S	3000 ± 100	118 ± 4
2	ASD-CAPW2005	3106A-24-11S	5000 ± 100	197 ± 4

Delta Part Number: ASD-CAPW2103, ASD-CAPW2105

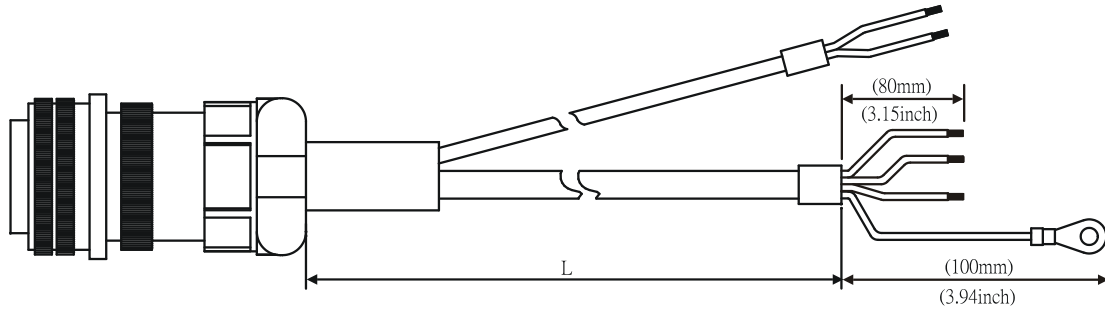

Title	Part No.	Straight	L	
			mm	inch
1	ASD-CAPW2103	3106A-24-11S	3000 ± 100	118 ± 4
2	ASD-CAPW2105	3106A-24-11S	5000 ± 100	197 ± 4

Delta Part Number: ASD-CAPW2203, ASD-CAPW2205

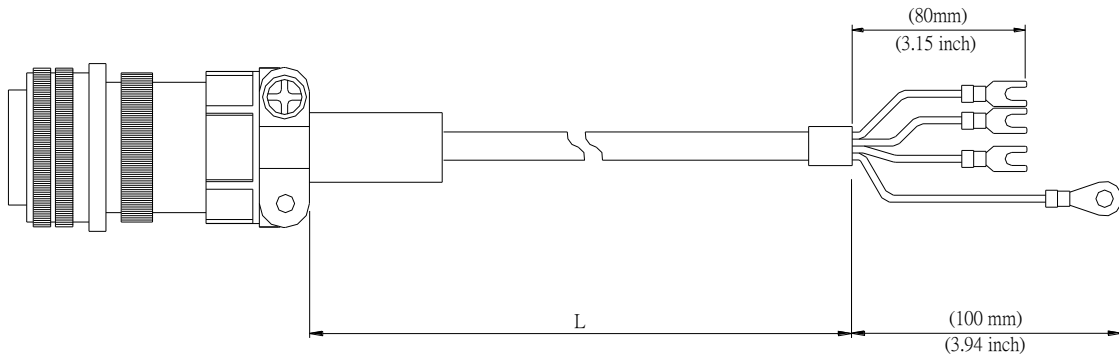

Title	Part No.	Straight	L	
			mm	inch
1	ASD-CAPW2203	3106A-24-11S	3000 ± 100	118 ± 4
2	ASD-CAPW2205	3106A-24-11S	5000 ± 100	197 ± 4

Delta Part Number: ASD-CAPW2303, ASD-CAPW2305 (for motors with brake)

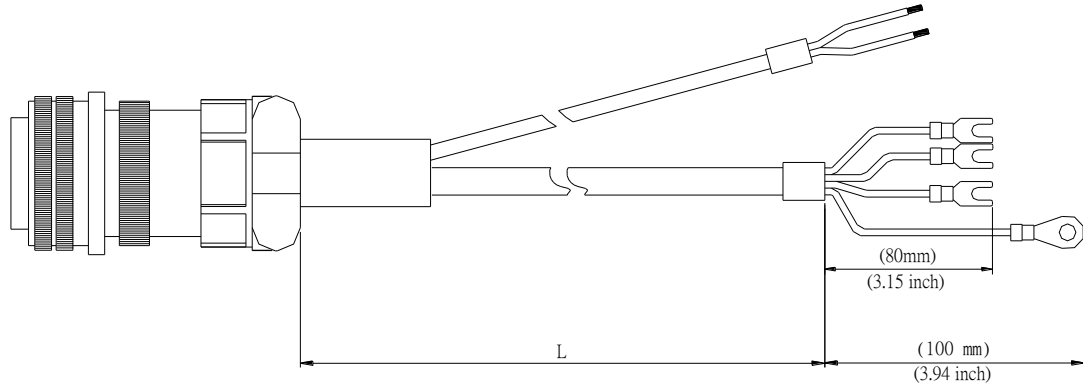

Title	Part No.	Straight	L	
			mm	inch
1	ASD-CAPW2303	3106A-24-11S	3000 ± 100	118 ± 4
2	ASD-CAPW2305	3106A-24-11S	5000 ± 100	197 ± 4

Delta Part Number: ASD-CAPW3203, ASD-CAPW3205 (for 4.5 kW models)

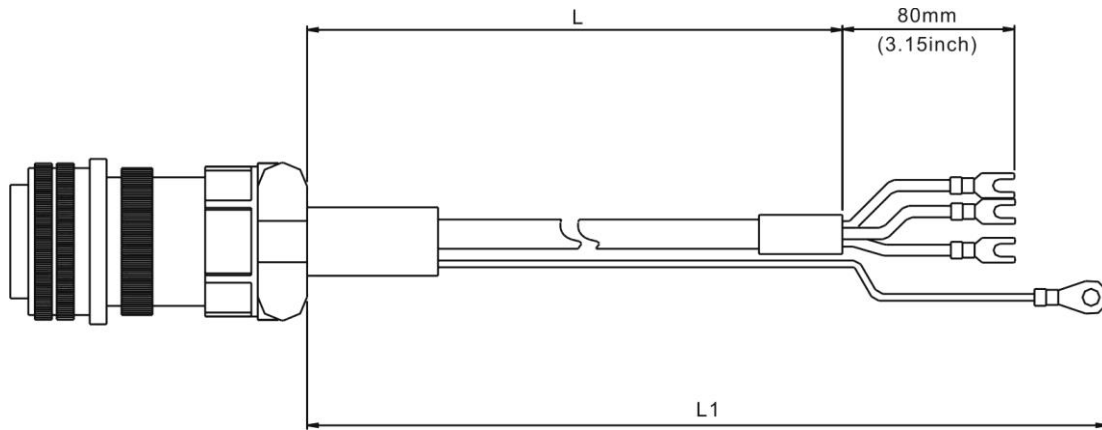

Item	Part No.	Straight	L		L1	
			mm	inch	mm	inch
1	ASD-CAPW3203	MS 3106-24-11S	3000 ± 100	118 ± 4	3100±100	122 ± 4
2	ASD-CAPW3205	MS 3106-24-11S	5000 ± 100	197 ± 4	5100±100	201 ± 4

Delta Part Number: ASD-CAPW3303, ASD-CAPW3305 (for motors with brake)

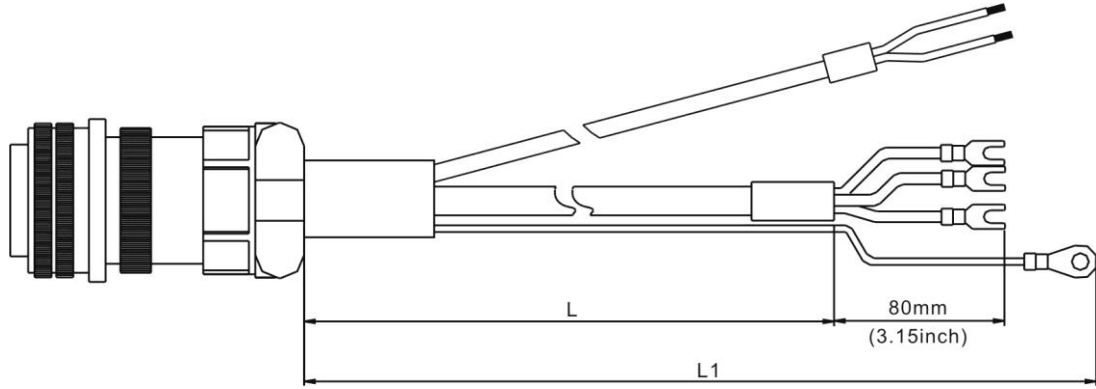

Item	Part No.	Straight	L		L1	
			mm	inch	mm	inch
1	ASD-CAPW3303	MS 3106-24-11S	3000±100	118 ± 4	3100±100	122 ± 4
2	ASD-CAPW3305	MS 3106-24-11S	5000±100	197 ± 4	5100±100	201 ± 4

■ Encoder Connectors

Delta Part Number: ASD-ABEN0000

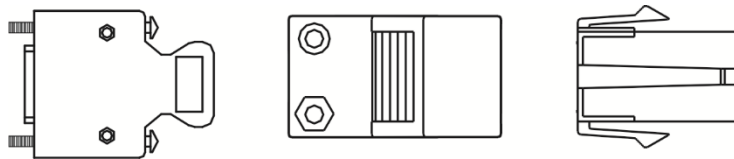

Delta Part Number: ASD-CAEN1000

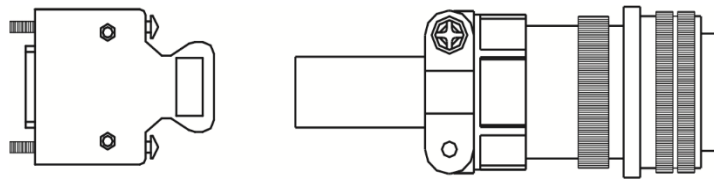

■ Incremental Type Encoder Cables

Delta Part Number: ASD-ABEN0003, ASD-ABEN0005

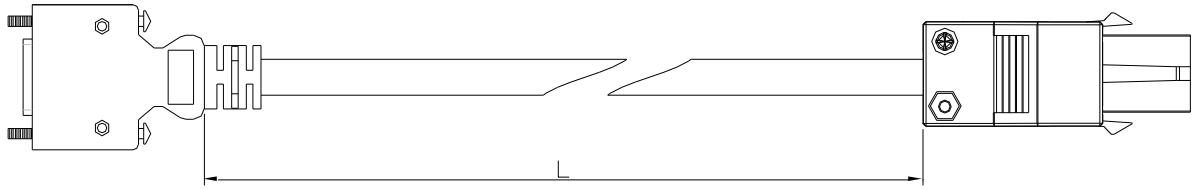

Title	Part No.	L	
		mm	inch
1	ASD-ABEN0003	3000 ± 100	118 ± 4
2	ASD-ABEN0005	5000 ± 100	197 ± 4

Delta Part Number: ASD-CAEN1003, ASD-CAEN1005

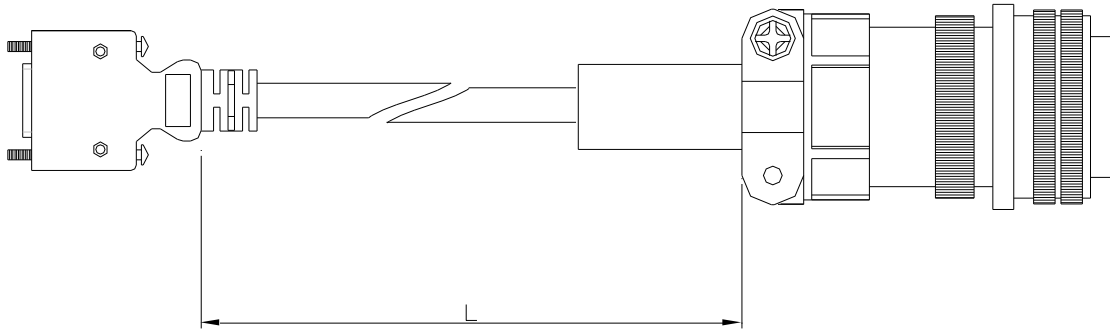

Title	Part No.	Straight	L	
			mm	inch
1	ASD-CAEN1003	3106A-20-29S	3000 ± 100	118 ± 4
2	ASD-CAEN1005	3106A-20-29S	5000 ± 100	197 ± 4

■ Absolute Type Encoder Cables

Delta Part Number: ASD-A2EB0003, ASD-A2EB0005

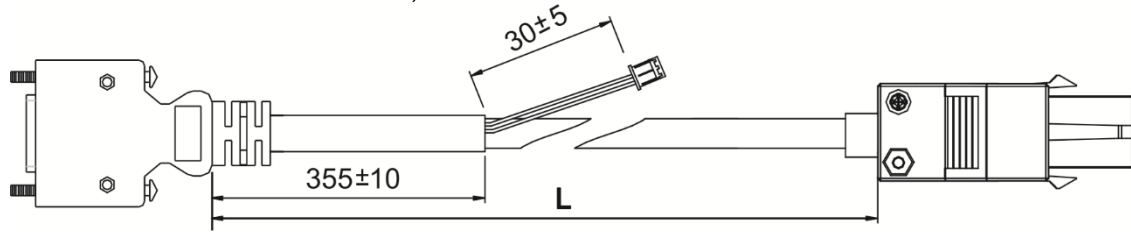

Title	Part No.	L	
		mm	inch
1	ASD-A2EB0003	3000 ± 100	118 ± 4
2	ASD-A2EB0005	5000 ± 100	197 ± 4

Delta Part Number: ASD-A2EB1003, ASD-A2EB1005

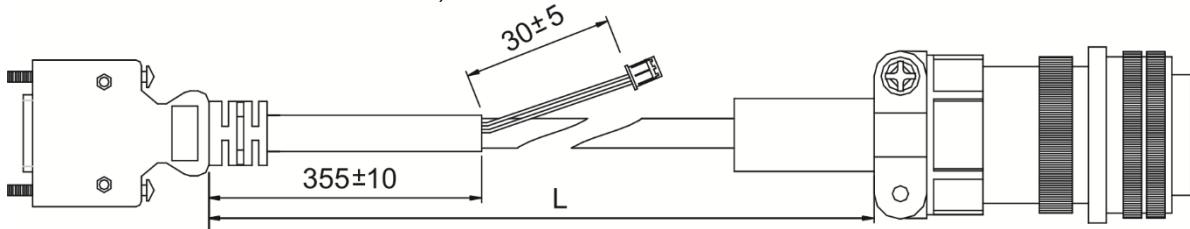

Title	Model Name	L	
		mm	inch
1	ASD-A2EB1003	3000 ± 100	118 ± 4
2	ASD-A2EB1005	5000 ± 100	197 ± 4

■ **Battery Box Cord AW (connects to the battery on the encoder cable)**

Delta Part Number: 3864573700

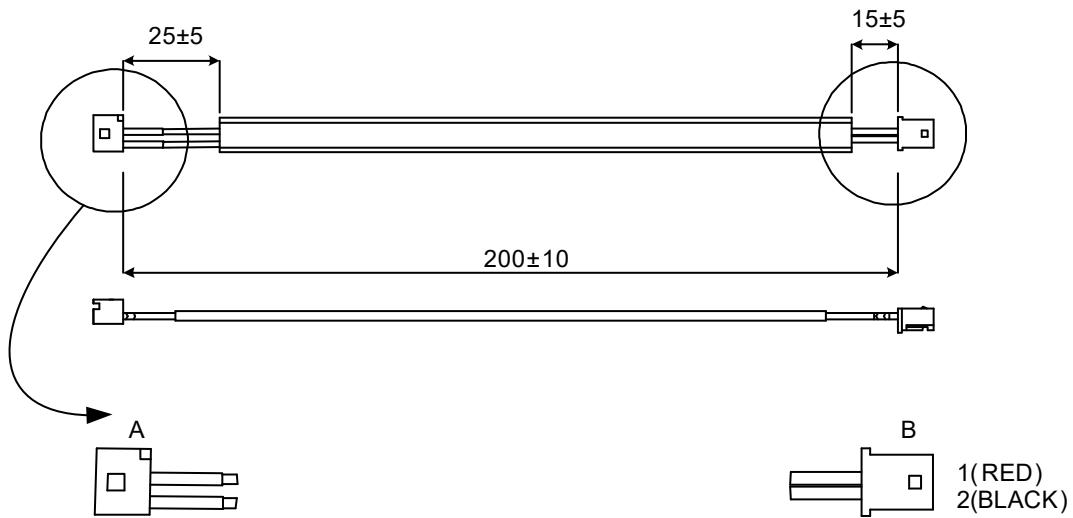

Unit: mm

■ **Battery Box Cord IW (connects to CN8)**

Delta Part Number: 3864811900

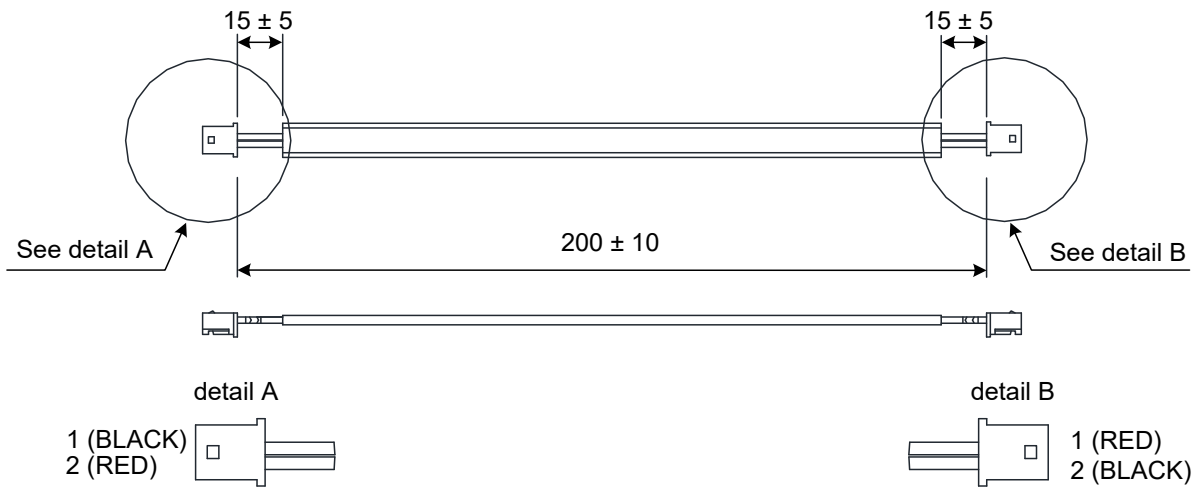

Unit: mm

■ Battery Boxes

Single Battery Box

Delta Part Number: ASD-MDBT0100

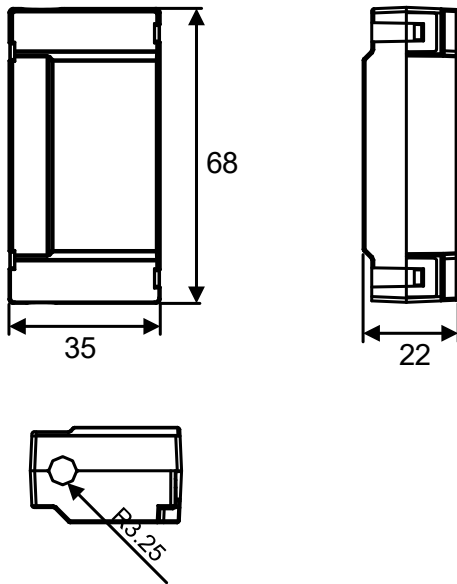

Unit: mm

Dual Battery Box

Delta Part Number: ASD-MDBT0200

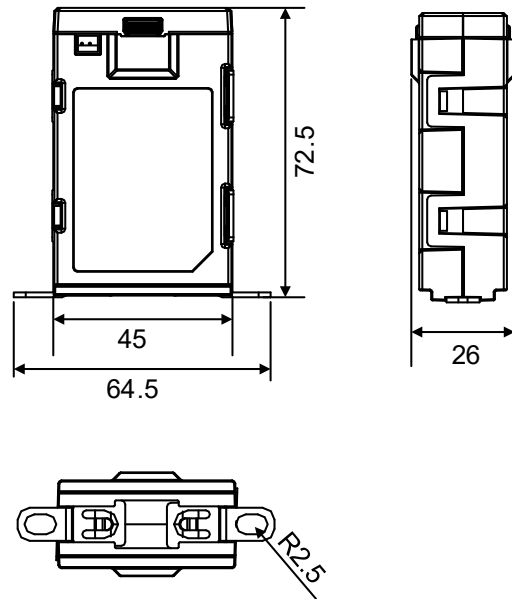

Unit: mm

■ I/O Signal Connector

Delta Part Number: ASD-CN5C0050

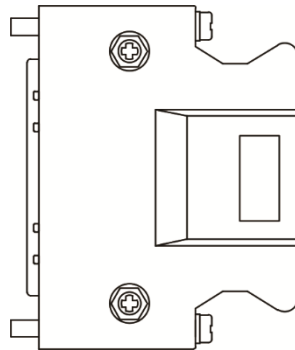

■ I/O Terminal Block Module

Delta Part Number: ASD-BM-50A

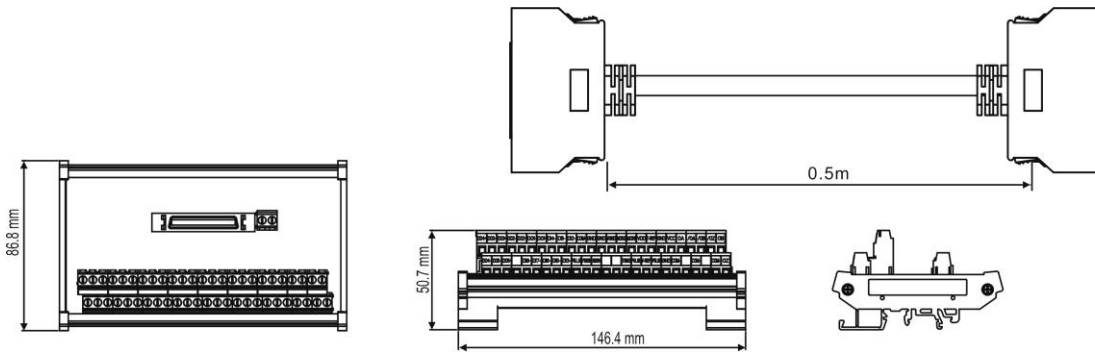

■ RS-232 Communication Cable

Delta Part Number: ASD-CARS0003

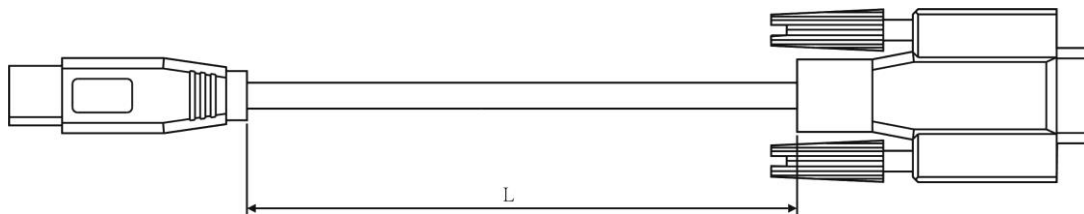

Title	Part No.	L	
		mm	inch
1	ASD-CARS0003	3000 ± 100	118 ± 4

■ Communication Cable between Drive and Computer (for PC)

Delta Part Number: DOP-CAUSBAB

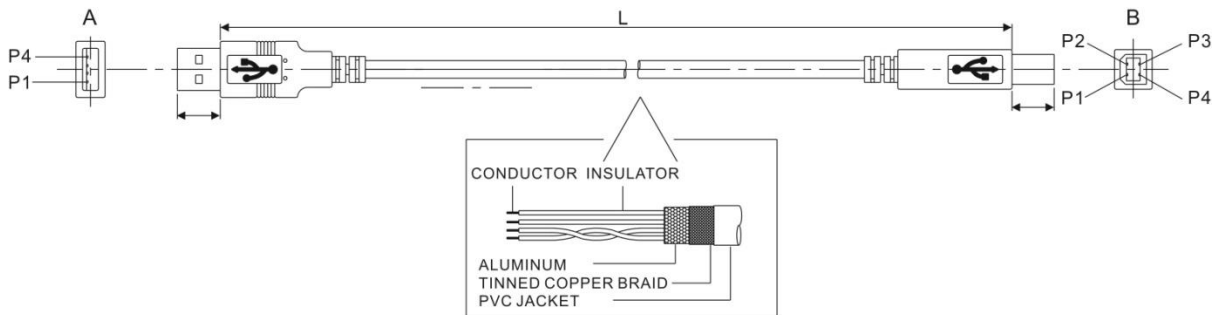

Title	Part No.	L	
		mm	inch
1	DOP-CAUSBAB	1400 ± 30	55 ± 1.2

■ CANopen Communication Cable

Delta Part Number: TAP-CB03, TAP-CB05

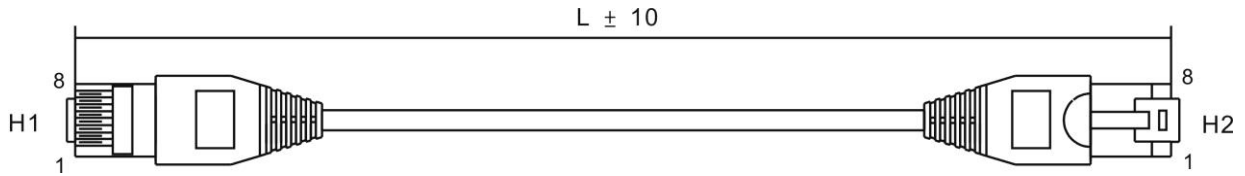

Title	Part No.	L	
		mm	inch
1	TAP-CB03	300 ± 10	11 ± 0.4
2	TAP-CB05	500 ± 10	19 ± 0.4

■ CANopen Distribution Box

Delta Part Number: TAP-CN03

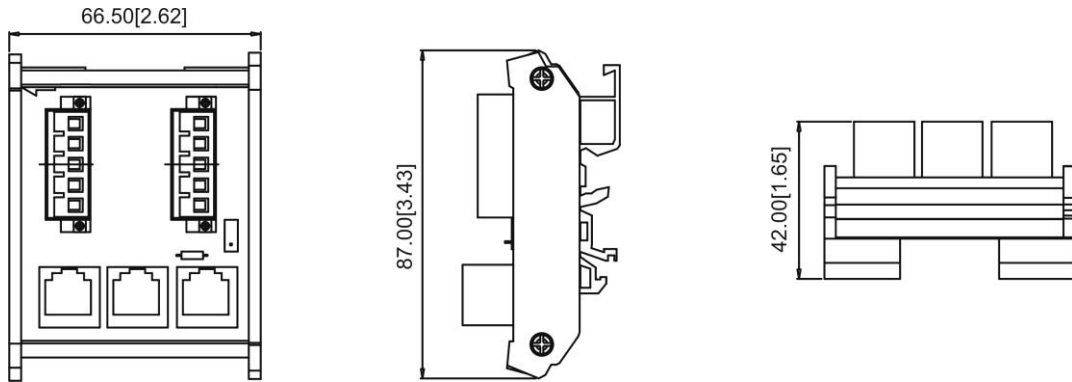

Unit: mm [inch]

■ RS-485 Connector

Delta Part Number: ASD-CNIE0B06

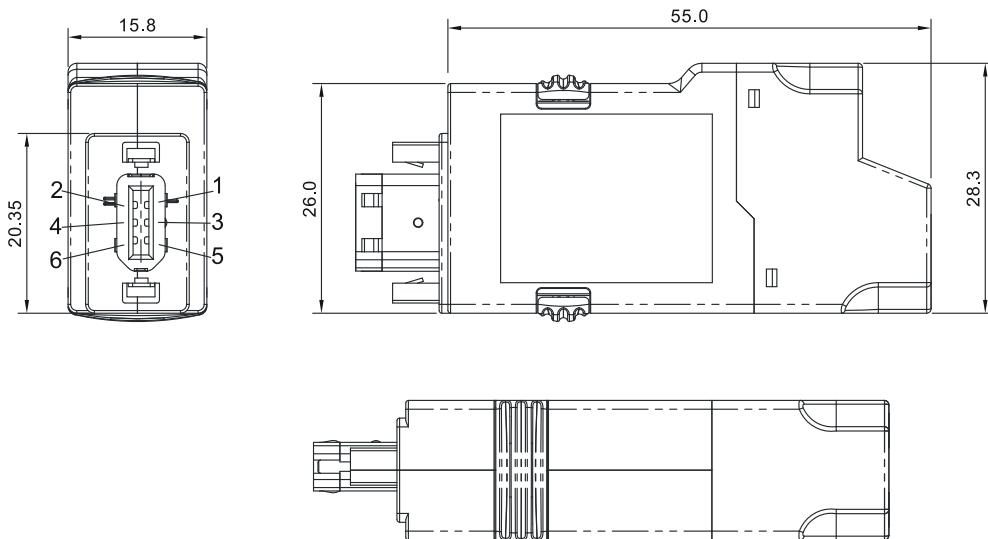

Unit: mm

■ CN1 Convenient Connector

Delta Part Number: ASD-IF-SC5020

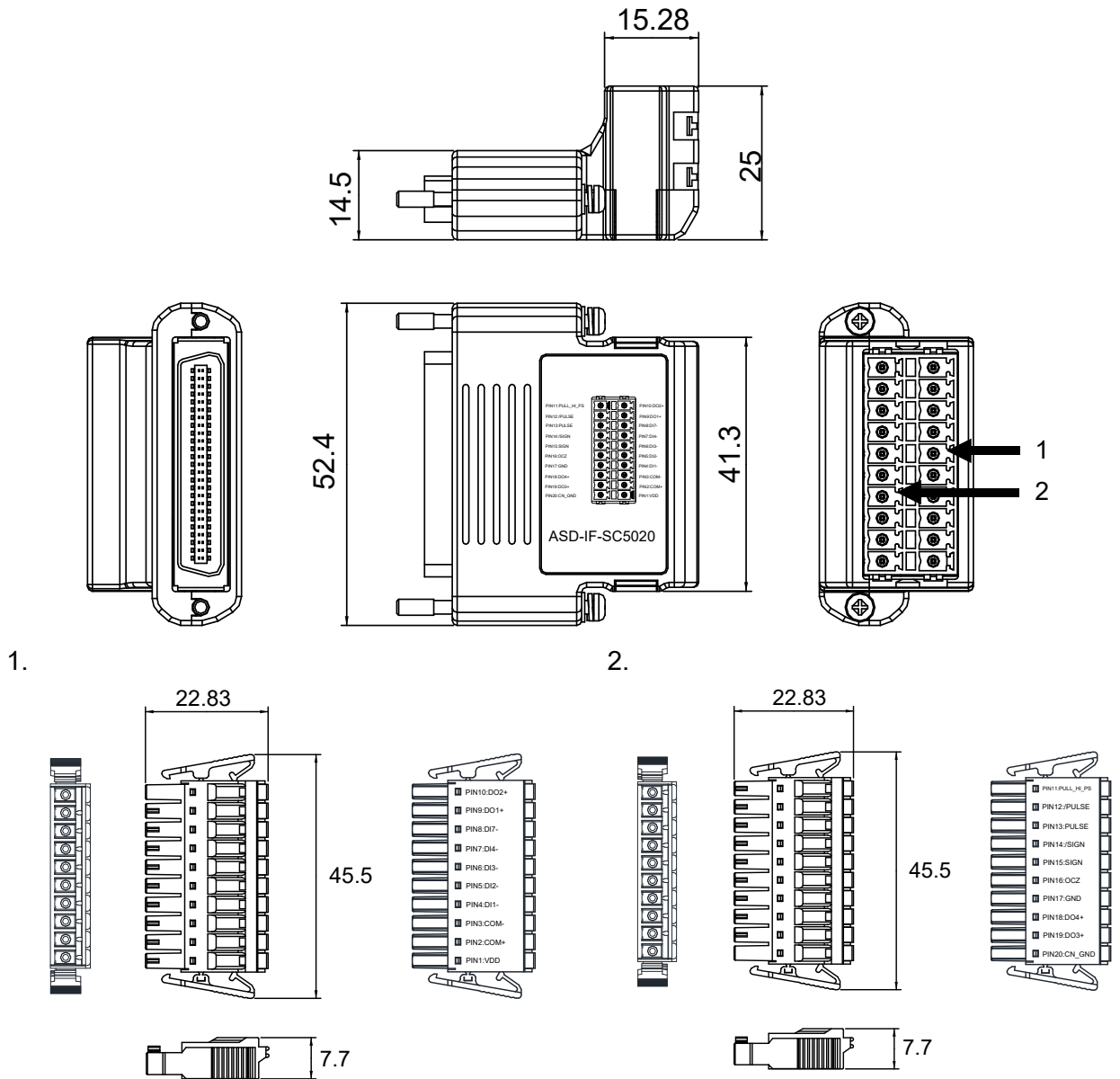

Unit: mm

Optional Accessories – 220V Series

100 W Servo Drive and 50 W Low Inertia Servo Motor

Servo Drive	ASD-A2-0121-□
Low Inertia Servo Motor	ECMA-C1040F□S
Motor Power Cable (Without Brake)	ASD-ABPW000X
Power Connector (Without Brake)	ASDBCAPW0000
Motor Power Cable (With Brake)	ASD-ABPW010X
Power Connector (With Brake)	ASDBCAPW0100
Incremental Type Encoder Cable	ASD-ABEN000X
Absolute Type Encoder Cable	ASD-A2EB000X
Encoder Connector	ASD-ABEN0000

(X=3 indicates that the cable length is 3 m; X=5 indicates that the cable length is 5 m)

100 W Servo Drive and 100 W Low Inertia Servo Motor

Servo Drive	ASD-A2-0121-□
Low Inertia Servo Motor	ECMA-C△0401□S
Motor Power Cable (Without Brake)	ASD-ABPW000X
Power Connector (Without Brake)	ASDBCAPW0000
Motor Power Cable (With Brake)	ASD-ABPW010X
Power Connector (With Brake)	ASDBCAPW0100
Incremental Type Encoder Cable	ASD-ABEN000X
Absolute Type Encoder Cable	ASD-A2EB000X
Encoder Connector	ASD-ABEN0000

(X=3 indicates that the cable length is 3 m; X=5 indicates that the cable length is 5 m)

200 W Servo Drive and 200 W Low Inertia Servo Motor

Servo Drive	ASD-A2-0221-□
Low Inertia Servo Motor	ECMA-C△0602□S
Motor Power Cable (Without Brake)	ASD-ABPW000X
Power Connector (Without Brake)	ASDBCAPW0000
Motor Power Cable (With Brake)	ASD-ABPW010X
Power Connector (With Brake)	ASDBCAPW0100
Incremental Type Encoder Cable	ASD-ABEN000X
Absolute Type Encoder Cable	ASD-A2EB000X
Encoder Connector	ASD-ABEN0000

(X=3 indicates that the cable length is 3 m; X=5 indicates that the cable length is 5 m)

400 W Servo Drive and 400 W Low Inertia Servo Motor

Servo Drive	ASD-A2-0421-□
Low Inertia Servo Motor	ECMA-C△0604□S ECMA-C△0604□H ECMA-C△0804□7
Motor Power Cable (Without Brake)	ASD-ABPW000X
Power Connector (Without Brake)	ASDBCAPW0000
Motor Power Cable (With Brake)	ASD-ABPW010X
Power Connector (With Brake)	ASDBCAPW0100
Incremental Type Encoder Cable	ASD-ABEN000X
Absolute Type Encoder Cable	ASD-A2EB000X
Encoder Connector	ASD-ABEN0000

(X=3 indicates that the cable length is 3 m; X=5 indicates that the cable length is 5 m)

400 W Servo Drive and 500 W Medium Inertia Servo Motor

Servo Drive	ASD-A2-0421-□
Medium Inertia Servo Motor	ECMA-E△1305□S
Motor Power Cable (Without Brake)	ASD-CAPW100X
Motor Power Cable (With Brake)	ASD-CAPW110X
Power Connector	ASD-CAPW1000
Incremental Type Encoder Cable	ASD-CAEN100X
Absolute Type Encoder Cable	ASD-A2EB100X
Encoder Connector	ASD-CAEN1000

(X=3 indicates that the cable length is 3 m; X=5 indicates that the cable length is 5 m)

400 W Servo Drive and 300 W High Inertia Servo Motor

Servo Drive	ASD-A2-0421-□
High Inertia Servo Motor	ECMA-G△1303□S
Motor Power Cable (Without Brake)	ASD-CAPW100X
Motor Power Cable (With Brake)	ASD-CAPW110X
Power Connector	ASD-CAPW1000
Incremental Type Encoder Cable	ASD-CAEN100X
Absolute Type Encoder Cable	ASD-A2EB100X
Encoder Connector	ASD-CAEN1000

(X=3 indicates that the cable length is 3 m; X=5 indicates that the cable length is 5 m)

750 W Servo Drive and 750 W Low Inertia Servo Motor

Servo Drive	ASD-A2-0721-□
Low Inertia Servo Motor	ECMA-C△0807□S ECMA-C△0807□H ECMA-C△0907□S
Motor Power Cable (Without Brake)	ASD-ABPW000X
Power Connector (Without Brake)	ASDBCAPW0000
Motor Power Cable (With Brake)	ASD-ABPW010X
Power Connector (With Brake)	ASDBCAPW0100
Incremental Type Encoder Cable	ASD-ABEN000X
Absolute Type Encoder Cable	ASD-A2EB000X
Encoder Connector	ASD-ABEN0000

(X=3 indicates that the cable length is 3 m; X=5 indicates that the cable length is 5 m)

750 W Servo Drive and 500 W Medium-High Inertia Servo Motor

Servo Drive	ASD-A2-0721-□
Medium-High Inertia Servo Motor	ECMA-F△1305□S
Motor Power Cable (Without Brake)	ASD-CAPW100X
Motor Power Cable (With Brake)	ASD-CAPW110X
Power Connector	ASD-CAPW1000
Incremental Type Encoder Cable	ASD-CAEN100X
Absolute Type Encoder Cable	ASD-A2EB100X
Encoder Connector	ASD-CAEN1000

(X=3 indicates that the cable length is 3 m; X=5 indicates that the cable length is 5 m)

750 W Servo Drive and 600 W High Inertia Servo Motor

Servo Drive	ASD-A2-0721-□
High Inertia Servo Motor	ECMA-G Δ 1306□S
Motor Power Cable (Without Brake)	ASD-CAPW100X
Motor Power Cable (With Brake)	ASD-CAPW110X
Power Connector	ASD-CAPW1000
Incremental Type Encoder Cable	ASD-CAEN100X
Absolute Type Encoder Cable	ASD-A2EB100X
Encoder Connector	ASD-CAEN1000

(X=3 indicates that the cable length is 3 m; X=5 indicates that the cable length is 5 m)

1 kW Servo Drive and 1 kW Low Inertia Servo Motor

Servo Drive	ASD-A2-1021-□
Low Inertia Servo Motor	ECMA-C Δ 1010□S
Motor Power Cable (Without Brake)	ASD-CAPW100X
Motor Power Cable (With Brake)	ASD-CAPW110X
Power Connector	ASD-CAPW1000
Incremental Type Encoder Cable	ASD-CAEN100X
Absolute Type Encoder Cable	ASD-A2EB100X
Encoder Connector	ASD-CAEN1000

(X=3 indicates that the cable length is 3 m; X=5 indicates that the cable length is 5 m)

1 kW Servo Drive and 1 kW Low Inertia Servo Motor

Servo Drive	ASD-A2-1021-□
Low Inertia Servo Motor	ECMA-C Δ 0910□S
Motor Power Cable (Without Brake)	ASD-ABPW000X
Motor Power Cable (With Brake)	ASD-ABPW010X
Power Cable (Without Brake)	ASDBCAPW0000
Power Cable (With Brake)	ASDBCAPW0100
Incremental Type Encoder Cable	ASD-ABEN000X
Absolute Type Encoder Cable	ASD-A2EB000X
Encoder Connector	ASD-ABEN0000

(X=3 indicates that the cable length is 3 m; X=5 indicates that the cable length is 5 m)

1 kW Servo Drive and 1 kW Medium Inertia Servo Motor

Servo Drive	ASD-A2-1021-□
Medium Inertia Servo Motor	ECMA-E Δ 1310□S
Motor Power Cable (Without Brake)	ASD-CAPW100X
Motor Power Cable (With Brake)	ASD-CAPW110X
Power Connector	ASD-CAPW1000
Incremental Type Encoder Cable	ASD-CAEN100X
Absolute Type Encoder Cable	ASD-A2EB100X
Encoder Connector	ASD-CAEN1000

(X=3 indicates that the cable length is 3 m; X=5 indicates that the cable length is 5 m)

1 kW Servo Drive and 850 W Medium-High Inertia Servo Motor

Servo Drive	ASD-A2-1021-□
Medium-High Inertia Servo Motor	ECMA-F Δ 1308□S
Motor Power Cable (Without Brake)	ASD-CAPW100X
Motor Power Cable (With Brake)	ASD-CAPW110X
Power Connector	ASD-CAPW1000
Incremental Type Encoder Cable	ASD-CAEN100X
Absolute Type Encoder Cable	ASD-A2EB100X
Encoder Connector	ASD-CAEN1000

(X=3 indicates that the cable length is 3 m; X=5 indicates that the cable length is 5 m)

1 kW Servo Drive and 900 W High Inertia Servo Motor

Servo Drive	ASD-A2-1021-□
High Inertia Servo Motor	ECMA-G Δ 1309□S
Motor Power Cable (Without Brake)	ASD-CAPW100X
Motor Power Cable (With Brake)	ASD-CAPW110X
Power Connector	ASD-CAPW1000
Incremental Type Encoder Cable	ASD-CAEN100X
Absolute Type Encoder Cable	ASD-A2EB100X
Encoder Connector	ASD-CAEN1000

(X=3 indicates that the cable length is 3 m; X=5 indicates that the cable length is 5 m)

1.5 kW Servo Drive and 1.5 kW Medium Inertia Servo Motor

Servo Drive	ASD-A2-1521-□
Medium Inertia Servo Motor	ECMA-E Δ 1315□S
Motor Power Cable (Without Brake)	ASD-CAPW100X
Motor Power Cable (With Brake)	ASD-CAPW110X
Power Connector	ASD-CAPW1000
Incremental Type Encoder Cable	ASD-CAEN100X
Absolute Type Encoder Cable	ASD-A2EB100X
Encoder Connector	ASD-CAEN1000

(X=3 indicates that the cable length is 3 m; X=5 indicates that the cable length is 5 m)

2 kW Servo Drive and 2 kW Low Inertia Servo Motor

Servo Drive	ASD-A2-2023-□
Low Inertia Servo Motor	ECMA-C Δ 1020□S
Motor Power Cable (Without Brake)	ASD-A2PW100X
Motor Power Cable (With Brake)	ASD-A2PW110X
Power Connector	ASD-CAPW1000
Incremental Type Encoder Cable	ASD-CAEN100X
Absolute Type Encoder Cable	ASD-A2EB100X
Encoder Connector	ASD-CAEN1000

(X=3 indicates that the cable length is 3 m; X=5 indicates that the cable length is 5 m)

2 kW Servo Drive and 2 kW Medium Inertia Servo Motor

Servo Drive	ASD-A2-2023-□
Medium Inertia Servo Motor	ECMA-E Δ 1320□S
Motor Power Cable (Without Brake)	ASD-A2PW100X
Motor Power Cable (With Brake)	ASD-A2PW110X
Power Connector	ASD-CAPW1000
Incremental Type Encoder Cable	ASD-CAEN100X
Absolute Type Encoder Cable	ASD-A2EB100X
Encoder Connector	ASD-CAEN1000

(X=3 indicates that the cable length is 3 m; X=5 indicates that the cable length is 5 m)

2 kW Servo Drive and 2 kW Medium Inertia Servo Motor

Servo Drive	ASD-A2-2023-□
Medium Inertia Servo Motor	ECMA-E Δ 1820□S
Motor Power Cable (Without Brake)	ASD-CAPW200X
Motor Power Cable (With Brake)	ASD-CAPW210X
Power Connector	ASD-CAPW2000
Incremental Type Encoder Cable	ASD-CAEN100X
Absolute Type Encoder Cable	ASD-A2EB100X
Encoder Connector	ASD-CAEN1000

(X=3 indicates that the cable length is 3 m; X=5 indicates that the cable length is 5 m)

2 kW Servo Drive and 1.3 kW Medium-High Inertia Servo Motor

Servo Drive	ASD-A2-2023-□
Medium-High Inertia Servo Motor	ECMA-F Δ 1313□S
Motor Power Cable (Without Brake)	ASD-A2PW100X
Motor Power Cable (With Brake)	ASD-A2PW110X
Power Connector	ASD-CAPW1000
Incremental Type Encoder Cable	ASD-CAEN100X
Absolute Type Encoder Cable	ASD-A2EB100X
Encoder Connector	ASD-CAEN1000

(X=3 indicates that the cable length is 3 m; X=5 indicates that the cable length is 5 m)

2 kW Servo Drive and 1.8 kW Medium-High Inertia Servo Motor

Servo Drive	ASD-A2-2023-□
Medium-High Inertia Servo Motor	ECMA-F Δ 1318□S
Motor Power Cable (Without Brake)	ASD-A2PW100X
Motor Power Cable (With Brake)	ASD-A2PW110X
Power Connector	ASD-CAPW1000
Incremental Type Encoder Cable	ASD-CAEN100X
Absolute Type Encoder Cable	ASD-A2EB100X
Encoder Connector	ASD-CAEN1000

(X=3 indicates that the cable length is 3 m; X=5 indicates that the cable length is 5 m)

3 kW Servo Drive and 3 kW Low Inertia Servo Motor

Servo Drive	ASD-A2-3023-□
Low Inertia Servo Motor	ECMA-C Δ 1330□4
Motor Power Cable (Without Brake)	ASD-A2PW100X
Motor Power Cable (With Brake)	ASD-A2PW110X
Power Connector	ASD-CAPW1000
Incremental Type Encoder Cable	ASD-CAEN100X
Absolute Type Encoder Cable	ASD-A2EB100X
Encoder Connector	ASD-CAEN1000

(X=3 indicates that the cable length is 3 m; X=5 indicates that the cable length is 5 m)

3 kW Servo Drive and 3 kW Medium Inertia Servo Motor

Servo Drive	ASD-A2-3023-□
Medium Inertia Servo Motor	ECMA-E Δ 1830□S
Motor Power Cable (Without Brake)	ASD-CAPW200X
Motor Power Cable (With Brake)	ASD-CAPW210X
Power Connector	ASD-CAPW2000
Incremental Type Encoder Cable	ASD-CAEN100X
Absolute Type Encoder Cable	ASD-A2EB100X
Encoder Connector	ASD-CAEN1000

(X=3 indicates that the cable length is 3 m; X=5 indicates that the cable length is 5 m)

3 kW Servo Drive and 3.5 kW Medium Inertia Servo Motor

Servo Drive	ASD-A2-3023-□
Medium Inertia Servo Motor	ECMA-E Δ 1835□S
Motor Power Cable (Without Brake)	ASD-CAPW200X
Motor Power Cable (With Brake)	ASD-CAPW210X
Power Connector	ASD-CAPW2000
Incremental Type Encoder Cable	ASD-CAEN100X
Absolute Type Encoder Cable	ASD-A2EB100X
Encoder Connector	ASD-CAEN1000

(X=3 indicates that the cable length is 3 m; X=5 indicates that the cable length is 5 m)

3 kW Servo Drive and 3 kW Medium-High Inertia Servo Motor

Servo Drive	ASD-A2-3023-□
Medium-High Inertia Servo Motor	ECMA-F Δ 1830□S
Motor Power Cable (Without Brake)	ASD-CAPW200X
Motor Power Cable (With Brake)	ASD-CAPW210X
Power Connector	ASD-CAPW2000
Incremental Type Encoder Cable	ASD-CAEN100X
Absolute Type Encoder Cable	ASD-A2EB100X
Encoder Connector	ASD-CAEN1000

(X=3 indicates that the cable length is 3 m; X=5 indicates that the cable length is 5 m)

4.5 kW Servo Drive and 4.5 kW Medium-High Inertia Servo Motor

Servo Drive	ASD-A2-4523-□
Medium-High Inertia Servo Motor	ECMA-F Δ 1845□S
Motor Power Cable (Without Brake)	ASD-CAPW320X
Motor Power Cable (With Brake)	ASD-CAPW330X
Power Connector	ASD-CAPW2000
Incremental Type Encoder Cable	ASD-CAEN100X
Absolute Type Encoder Cable	ASD-A2EB100X
Encoder Connector	ASD-CAEN1000

(X=3 indicates that the cable length is 3 m; X=5 indicates that the cable length is 5 m)

5.5 kW Servo Drive and 5.5 kW Medium-High Inertia Servo Motor

Servo Drive	ASD-A2-5523-□
Medium-High Inertia Servo Motor	ECMA-F Δ 1855□3
Motor Power Cable (Without Brake)	-
Motor Power Cable (With Brake)	-
Power Connector	ASD-CAPW4000
Brake Connector	ASD-CNBR1000
Incremental Type Encoder Cable	ASD-CAEN100X
Absolute Type Encoder Cable	ASD-A2EB100X
Encoder Connector	ASD-CAEN1000

(X=3 indicates that the cable length is 3 m; X=5 indicates that the cable length is 5 m)

7.5 kW Servo Drive and 7.5 kW Medium-High Inertia Servo Motor

Servo Drive	ASD-A2-7523-□
Medium-High Inertia Servo Motor	ECMA-F△1875□3
Motor Power Cable (Without Brake)	-
Motor Power Cable (With Brake)	-
Power Connector	ASD-CAPW4000
Brake Connector	ASD-CNBR1000
Incremental Type Encoder Cable	ASD-CAEN100X
Absolute Type Encoder Cable	ASD-A2EB100X
Encoder Connector	ASD-CAEN1000

(X=3 indicates that the cable length is 3 m; X=5 indicates that the cable length is 5 m)

11 kW Servo Drive and 11 kW Medium-High Inertia Servo Motor

Servo Drive	ASD-A2-1B23-□
Medium-High Inertia Servo Motor	ECMA-F1221B□3
Motor Power Cable (Without Brake)	-
Motor Power Cable (With Brake)	-
Power Connector	ASD-CAPW4000
Brake Connector	ASD-CNBR1000
Incremental Type Encoder Cable	ASD-CAEN100X
Absolute Type Encoder Cable	ASD-A2EB100X
Encoder Connector	ASD-CAEN1000

(X=3 indicates that the cable length is 3 m; X=5 indicates that the cable length is 5 m)

15 kW Servo Drive and 15 kW Medium-High Inertia Servo Motor

Servo Drive	ASD-A2-1F23-□
Medium-High Inertia Servo Motor	ECMA-F1221F□S
Motor Power Cable (Without Brake)	-
Motor Power Cable (With Brake)	-
Power Connector	ASD-CAPW4000
Brake Connector	ASD-CNBR1000
Incremental Type Encoder Cable	ASD-CAEN100X
Absolute Type Encoder Cable	ASD-A2EB100X
Encoder Connector	ASD-CAEN1000

(X=3 indicates that the cable length is 3 m; X=5 indicates that the cable length is 5 m)

Note:

1. The boxes (□) at the ends of the servo drive model names are for optional configurations. Please refer to the ordering information of the actual purchased product.
2. The boxes (Δ) in the model names are for encoder resolution types. Please refer to Chapter 1 for further information.
3. The boxes (□) in the model names represent brake or keyway / oil seal.

■ Optional Accessories – 400V Series

750 W Servo Drive and 400 W Low Inertia Servo Motor

Servo Drive	ASD-A2-0743-□
Low Inertia Servo Motor	ECMA-JΔ0604□S
Motor Power Cable (Without Brake)	ASD-CAPW540X
Power Connector (Without Brake)	ASD-CAPW5400
Motor Power Cable (With Brake)	ASD-CAPW510X
Power Connector (With Brake)	ASD-CAPW5100
Incremental Type Encoder Cable	ASD-ABEN000X
Absolute Type Encoder Cable	ASD-A2EB000X
Encoder Connector	ASD-ABEN0000

(X=3 indicates that the cable length is 3 m; X=5 indicates that the cable length is 5 m)

750 W Servo Drive and 750 W Low Inertia Servo Motor

Servo Drive	ASD-A2-0743-□
Low Inertia Servo Motor	ECMA-JΔ0807□S
Motor Power Cable (Without Brake)	ASD-CAPW540X
Power Connector (Without Brake)	ASD-CAPW5400
Motor Power Cable (With Brake)	ASD-CAPW510X
Power Connector (With Brake)	ASD-CAPW5100
Incremental Type Encoder Cable	ASD-ABEN000X
Absolute Type Encoder Cable	ASD-A2EB000X
Encoder Connector	ASD-ABEN0000

(X=3 indicates that the cable length is 3 m; X=5 indicates that the cable length is 5 m)

750 W Servo Drive and 750 W Low Inertia Servo Motor

Servo Drive	ASD-A2-0743-□
Low Inertia Servo Motor	ECMA-J△0907□S
Motor Power Cable (Without Brake)	ASD-CAPW540X
Power Connector (Without Brake)	ASD-CAPW5400
Motor Power Cable (With Brake)	ASD-CAPW510X
Power Connector (With Brake)	ASD-CAPW5100
Incremental Type Encoder Cable	ASD-ABEN000X
Absolute Type Encoder Cable	ASD-A2EB000X
Encoder Connector	ASD-ABEN0000

(X=3 indicates that the cable length is 3 m; X=5 indicates that the cable length is 5 m)

750 W Servo Drive and 500 W Medium Inertia Servo Motor

Servo Drive	ASD-A2-0743-□
Medium Inertia Servo Motor	ECMA- K△1305□S
Motor Power Cable (Without Brake)	ASD-CAPW100X
Motor Power Cable (With Brake)	ASD-CAPW110X
Power Connector	ASD-CAPW1000
Incremental Type Encoder Cable	ASD-CAEN100X
Absolute Type Encoder Cable	ASD-A2EB100X
Encoder Connector	ASD-CAEN1000

(X=3 indicates that the cable length is 3 m; X=5 indicates that the cable length is 5 m)

750 W Servo Drive and 500 W Medium-High Inertia Servo Motor

Servo Drive	ASD-A2-0743-□
Medium-High Inertia Servo Motor	ECMA- L△1305□S
Motor Power Cable (Without Brake)	ASD-CAPW100X
Motor Power Cable (With Brake)	ASD-CAPW110X
Power Connector	ASD-CAPW1000
Incremental Type Encoder Cable	ASD-CAEN100X
Absolute Type Encoder Cable	ASD-A2EB100X
Encoder Connector	ASD-CAEN1000

(X=3 indicates that the cable length is 3 m; X=5 indicates that the cable length is 5 m)

1 kW Servo Drive and 1 kW Low Inertia Servo Motor

Servo Drive	ASD-A2-1043-□
Low Inertia Servo Motor	ECMA-JΔ0910□S
Motor Power Cable (Without Brake)	ASD-CAPW540X
Power Connector (Without Brake)	ASD-CAPW5400
Motor Power Cable (With Brake)	ASD-CAPW510X
Power Connector (With Brake)	ASD-CAPW5100
Incremental Type Encoder Cable	ASD-ABEN000X
Absolute Type Encoder Cable	ASD-A2EB000X
Encoder Connector	ASD-ABEN0000

(X=3 indicates that the cable length is 3 m; X=5 indicates that the cable length is 5 m)

1 kW Servo Drive and 850 W High Inertia Servo Motor

Servo Drive	ASD-A2-1043-□
High Inertia Servo Motor	ECMA-LΔ1308□S
Motor Power Cable (Without Brake)	ASD-CAPW100X
Motor Power Cable (With Brake)	ASD-CAPW110X
Power Connector	ASD-CAPW1000
Incremental Type Encoder Cable	ASD-CAEN100X
Absolute Type Encoder Cable	ASD-A2EB100X
Encoder Connector	ASD-CAEN1000

(X=3 indicates that the cable length is 3 m; X=5 indicates that the cable length is 5 m)

1 kW Servo Drive and 1 kW Medium Inertia Servo Motor

Servo Drive	ASD-A2-1043-□
Medium Inertia Servo Motor	ECMA-KΔ1310□S
Motor Power Cable (Without Brake)	ASD-CAPW100X
Motor Power Cable (With Brake)	ASD-CAPW110X
Power Connector	ASD-CAPW1000
Incremental Type Encoder Cable	ASD-CAEN100X
Absolute Type Encoder Cable	ASD-A2EB100X
Encoder Connector	ASD-CAEN1000

(X=3 indicates that the cable length is 3 m; X=5 indicates that the cable length is 5 m)

1.5 kW Servo Drive and 900 W High Inertia Servo Motor

Servo Drive	ASD-A2-1543-□
High Inertia Servo Motor	ECMA-M Δ 1309□S
Motor Power Cable (Without Brake)	ASD-CAPW100X
Motor Power Cable (With Brake)	ASD-CAPW110X
Power Connector	ASD-CAPW1000
Incremental Type Encoder Cable	ASD-CAEN100X
Absolute Type Encoder Cable	ASD-A2EB100X
Encoder Connector	ASD-CAEN1000

(X=3 indicates that the cable length is 3 m; X=5 indicates that the cable length is 5 m)

1.5 kW Servo Drive and 1 kW Low Inertia Servo Motor

Servo Drive	ASD-A2-1543-□
Low Inertia Servo Motor	ECMA-J Δ 1010□S
Motor Power Cable (Without Brake)	ASD-CAPW100X
Motor Power Cable (With Brake)	ASD-CAPW110X
Power Connector	ASD-CAPW1000
Incremental Type Encoder Cable	ASD-CAEN100X
Absolute Type Encoder Cable	ASD-A2EB100X
Encoder Connector	ASD-CAEN1000

(X=3 indicates that the cable length is 3 m; X=5 indicates that the cable length is 5 m)

1.5 kW Servo Drive and 1.3 kW Medium-High Inertia Servo Motor

Servo Drive	ASD-A2-1543-□
Medium-High Inertia Servo Motor	ECMA-L Δ 1313□S
Motor Power Cable (Without Brake)	ASD-CAPW100X
Motor Power Cable (With Brake)	ASD-CAPW110X
Power Connector	ASD-CAPW1000
Incremental Type Encoder Cable	ASD-CAEN100X
Absolute Type Encoder Cable	ASD-A2EB100X
Encoder Connector	ASD-CAEN1000

(X=3 indicates that the cable length is 3 m; X=5 indicates that the cable length is 5 m)

1.5 kW Servo Drive and 1.5 kW Medium Inertia Servo Motor

Servo Drive	ASD-A2-1543-□
Medium Inertia Servo Motor	ECMA-K Δ 1315□S
Motor Power Cable (Without Brake)	ASD-CAPW100X
Motor Power Cable (With Brake)	ASD-CAPW110X
Power Connector	ASD-CAPW1000
Incremental Type Encoder Cable	ASD-CAEN100X
Absolute Type Encoder Cable	ASD-A2EB100X
Encoder Connector	ASD-CAEN1000

(X=3 indicates that the cable length is 3 m; X=5 indicates that the cable length is 5 m)

2 kW Servo Drive and 2 kW Low Inertia Motor

Servo Drive	ASD-A2-2043-□
Low Inertia Servo Motor	ECMA-J Δ 1020□S
Motor Power Cable (Without Brake)	ASD-CAPW120X
Motor Power Cable (With Brake)	ASD-CAPW130X
Power Connector	ASD-CAPW1000
Incremental Type Encoder Cable	ASD-CAEN100X
Absolute Type Encoder Cable	ASD-A2EB100X
Encoder Connector	ASD-CAEN1000

(X=3 indicates that the cable length is 3 m; X=5 indicates that the cable length is 5 m)

2 kW Servo Drive and 2 kW Medium Inertia Servo Motor

Servo Drive	ASD-A2-2043-□
Medium Inertia Servo Motor	ECMA-K Δ 1320□S
Motor Power Cable (Without Brake)	ASD-CAPW120X
Motor Power Cable (With Brake)	ASD-CAPW130X
Power Connector	ASD-CAPW1000
Incremental Type Encoder Cable	ASD-CAEN100X
Absolute Type Encoder Cable	ASD-A2EB100X
Encoder Connector	ASD-CAEN1000

(X=3 indicates that the cable length is 3 m; X=5 indicates that the cable length is 5 m)

2 kW Servo Drive and 2 kW Medium Inertia Servo Motor

Servo Drive	ASD-A2-2043-□
Medium Inertia Servo Motor	ECMA-K Δ 1820□S
Motor Power Cable (Without Brake)	ASD-CAPW220X
Motor Power Cable (With Brake)	ASD-CAPW230X
Power Connector	ASD-CAPW2000
Incremental Type Encoder Cable	ASD-CAEN100X
Absolute Type Encoder Cable	ASD-A2EB100X
Encoder Connector	ASD-CAEN1000

(X=3 indicates that the cable length is 3 m; X=5 indicates that the cable length is 5 m)

3 kW Servo Drive and 3 kW Low Inertia Servo Motor

Servo Drive	ASD-A2-3043-□
Low Inertia Servo Motor	ECMA-J Δ 1330□4
Motor Power Cable(Without Brake)	ASD-CAPW120X
Motor Power Cable (With Brake)	ASD-CAPW130X
Power Connector	ASD-CAPW1000
Incremental Type Encoder Cable	ASD-CAEN100X
Absolute Type Encoder Cable	ASD-A2EB100X
Encoder Connector	ASD-CAEN1000

(X=3 indicates that the cable length is 3 m; X=5 indicates that the cable length is 5 m)

3 kW Servo Drive and 3 kW Medium-High Inertia Servo Motor

Servo Drive	ASD-A2-3043-□
Medium-High Inertia Servo Motor	ECMA- L Δ 11830□S
Motor Power Cable (Without Brake)	ASD-CAPW220X
Motor Power Cable (With Brake)	ASD-CAPW230X
Power Connector	ASD-CAPW2000
Incremental Type Encoder Cable	ASD-CAEN100X
Absolute Type Encoder Cable	ASD-A2EB100X
Encoder Connector	ASD-CAEN1000

(X=3 indicates that the cable length is 3 m; X=5 indicates that the cable length is 5 m)

4.5 kW Servo Drive and 4.5 kW Medium-High Inertia Servo Motor

Servo Drive	ASD-A2-4543-□
Medium-High Inertia Servo Motor	ECMA-L△1845□S
Motor Power Cable (Without Brake)	ASD-CAPW220X
Motor Power Cable (With Brake)	ASD-CAPW230X
Power Connector	ASD-CAPW2000
Incremental Type Encoder Cable	ASD-CAEN100X
Absolute Type Encoder Cable	ASD-A2EB100X
Encoder Connector	ASD-CAEN1000

(X=3 indicates that the cable length is 3 m; X=5 indicates that the cable length is 5 m)

5.5 kW Servo Drive and 5.5 kW Medium-High Inertia Servo Motor

Servo Drive	ASD-A2-5543-□
Medium-High Inertia Servo Motor	ECMA-L11855□3
Motor Power Cable (Without Brake)	ASD-CAPW220X
Motor Power Cable (With Brake)	ASD-CAPW230X
Power Connector	ASD-CAPW2000
Incremental Type Encoder Cable	ASD-CAEN100X
Absolute Type Encoder Cable	ASD-A2EB100X
Encoder Connector	ASD-CAEN1000

(X=3 indicates that the cable length is 3 m; X=5 indicates that the cable length is 5 m)

7.5 kW Servo Drive and 7.5 kW Medium-High Inertia Servo Motor

Servo Drive	ASD-A2-7543-□
Medium-High Inertia Servo Motor	ECMA-L11875□3
Motor Power Cable (Without Brake)	ASD-CAPW320X
Motor Power Cable (With Brake)	ASD-CAPW330X
Power Connector	ASD-CAPW2000
Incremental Type Encoder Cable	ASD-CAEN100X
Absolute Type Encoder Cable	ASD-A2EB100X
Encoder Connector	ASD-CAEN1000

(X=3 indicates that the cable length is 3 m; X=5 indicates that the cable length is 5 m)

Note:

1. The boxes (□) at the ends of the servo drive model names. For the actual model name, please refer to the ordering information of the actual purchased product.

2. The boxes (Δ) in the model names are for encoder resolution types. Please refer to Chapter 1 for further information.
3. The boxes (\square) in the model names represent brake or keyway / oil seal.

■ Other Accessories (for all ASDA-A2 series models)

Description	Delta Part Number
50-pin I/O Signal Connector (CN1)	ASD-CN500050
I/O Terminal Block Module	ASD-BM-50A
RS-232 Communication Cable	ASD-CARS0003
Communication Cable between Drive and Computer (for PC)	DOP-CAUSBAB
CANopen Communication Cable	TAP-CB03 / TAP-CB05
CANopen Distribution Box	TAP-CN03
RS-485 Connector	ASD-CNIE0B06
Regenerative Resistor 400W 40 Ω	BR400W040
Regenerative Resistor 1kW 20 Ω	BR1K0W020
Regenerative Resistor 1.5kW 5 Ω	BR1K5W005

(This page is intentionally left blank.)

Appendix B Maintenance and Inspection

Basic Inspection

Item	Content
General inspection	Periodically check if the screws of the servo drive, the connection between the motor shaft, and the mechanical system as well as the connection of terminal block and mechanical system are securely tightened.
	The gap of the control box and the installation of the cooling fan should be free from oil, water, or metallic particles. Also, the servo drive shall be free from the cutting powder of the drill.
	If the control box is installed in the site which contains harmful gas or is full of dust, please be ensured the servo drive is free from the harmful gas and dust.
	When making encoder cable or wire rods, please be ensured the wiring is correct. Otherwise, the motor may have sudden unintended acceleration or be burned.
Inspection before operation (has not applied to the power yet)	To avoid the electric shock, the ground terminal of the servo drive should firmly connect to the ground terminal of the control box. If the wiring is needed, wait at least 10 minutes after disconnecting the drive from the main supply power, or discharge electricity by discharge device.
	The splicing parts of the wiring terminal should be isolated.
	Make sure the wiring is correct so as to avoid the damage or any abnormality.
	Check if the electrically conductive objects including sheet metal (such as screws) or inflammable objects are not inside the servo drive.
	Check if the control switch is in OFF status.
	Do not place the servo drive or external regenerative resistor on inflammable objects.
	To prevent the electromagnetic brake from losing efficacy, please check if stop function and circuit break function can work normally.
	If the peripheral devices are interfered by the electronic instruments, please reduce electromagnetic interference with devices.
Inspection before	The encoder cable should avoid excessive stress. When the motor is running, please be ensured the cable is not frayed or over extended.

Item	Content
running the servo drive (has already applied to the power)	Please contact Delta if there is any vibration of the servo motor or unusual noise during the operation.
	Make sure the setting of the parameters is correct. Different machinery has different characteristics, please adjust the parameter according to the characteristic of each machinery.
	Please reset the parameter when the servo drive is in the status of SERVO OFF, or it may cause malfunction.
	When the relay is operating, contact Delta if there is no contact noise or there is other abnormal noise.
	Check if the power indicator and LED display work normally.

Maintenance

- Please use and store the product in a proper site.
- Periodically clean the surface of the servo drive and servo motor so as to avoid the dust and dirt.
- Do not disassemble any mechanical part when in maintenance.
- Periodically clean the ventilation ports of the servo drive and do not use the product in a high-temperature site for a long time so as to avoid the malfunction.

The lifetime of machinery parts

- DC Bus Capacitor
DC Bus Capacitor will be deteriorated by the affection of ripple current. Its lifetime is determined by the surrounding temperature and operating conditions. If it is operating in an air-conditioned site, its lifetime can be up to 10 years.
- Relay
The contact of switching power supply will wear and lead to poor contact. The lifetime of relay is influenced by the power supply capacity; thus, the accumulative time of switching power supply is about 100,000 times.
- Cooling Fan
In continuous operation, the lifetime of the cooling fan is 2 to 3 years. However, if there is any unusual noise or vibration during inspection, replacing a new one is a must.